

# TYPICAL FLOOR DETAILS

SmartJoist blocking panel or full depth cripple on each side required when supporting load bearing walls above.

Blocking panels required when SmartJoists are cantilevered

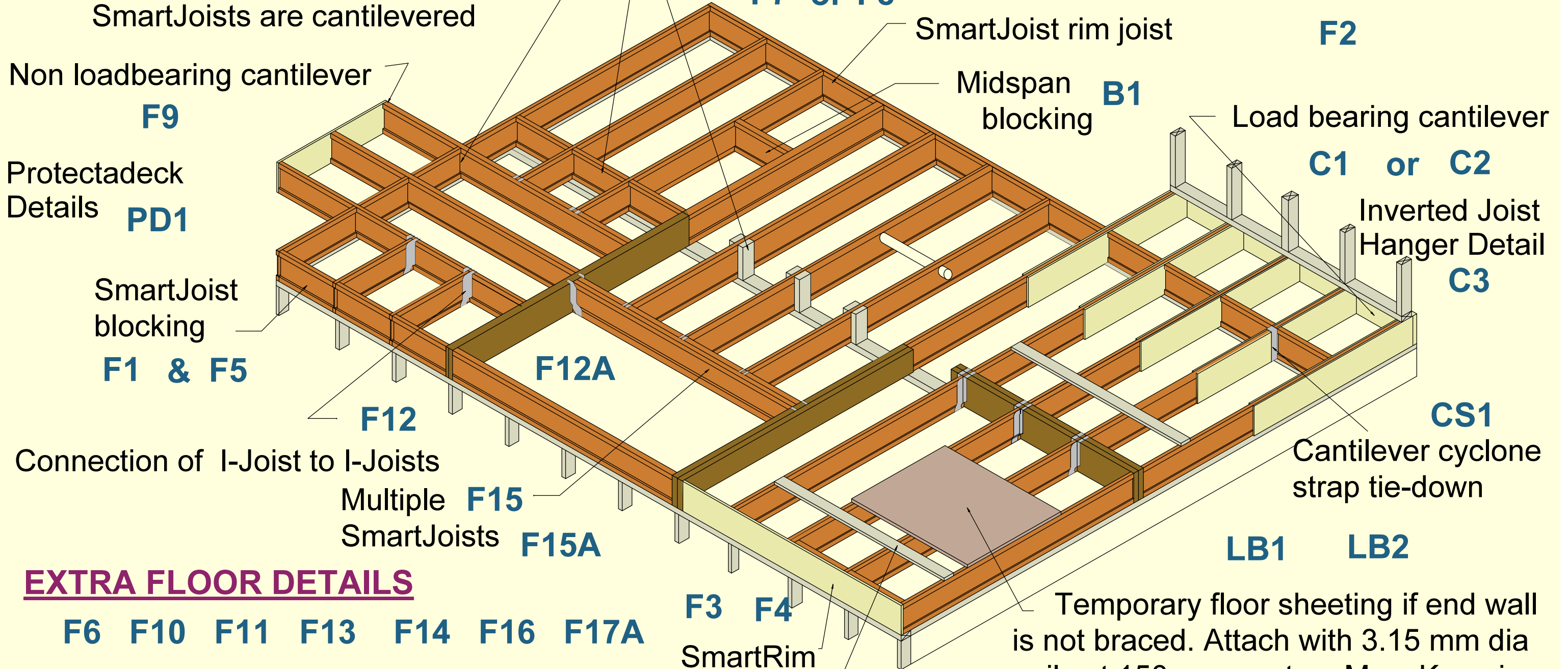

## EXTRA FLOOR DETAILS

F6 F10 F11 F13 F14 F16 F17A

F17 F18A F18 F19 F20 F21 F21A F22 F22A

F23 F24 F25 F26 F27 RA1 RA2 RA3

Temporary struts at 2400 mm centres. Nail struts to each joist with 2 of 3.15 mm diam x 65 nails.

# FLOOR DETAILS: Supporting Offset Load Bearing Wall details

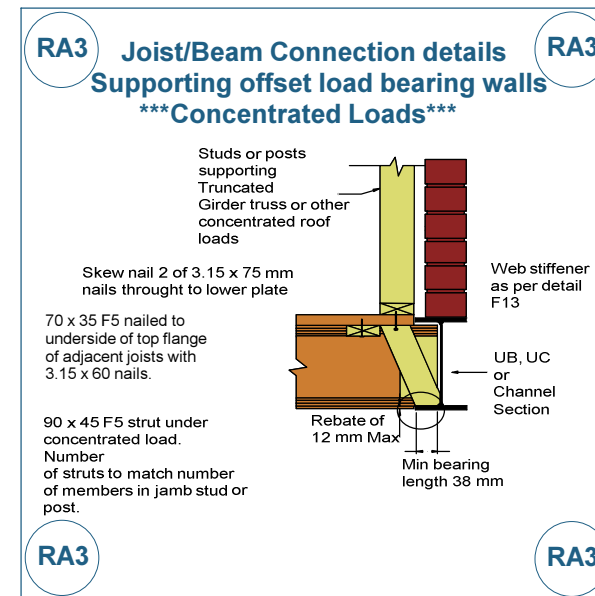
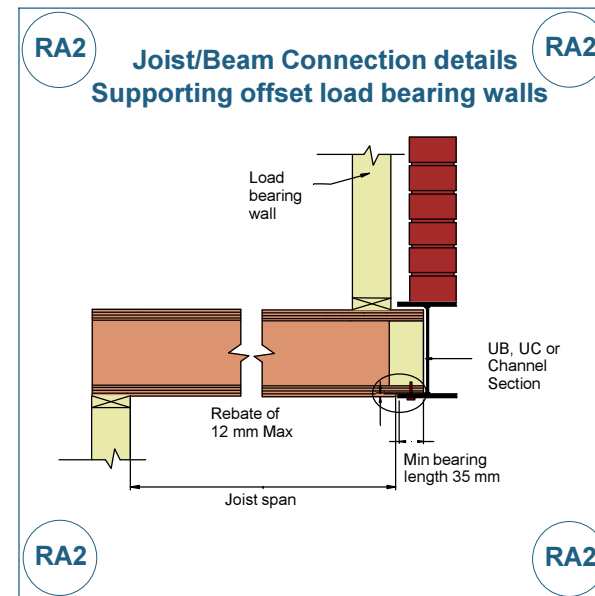
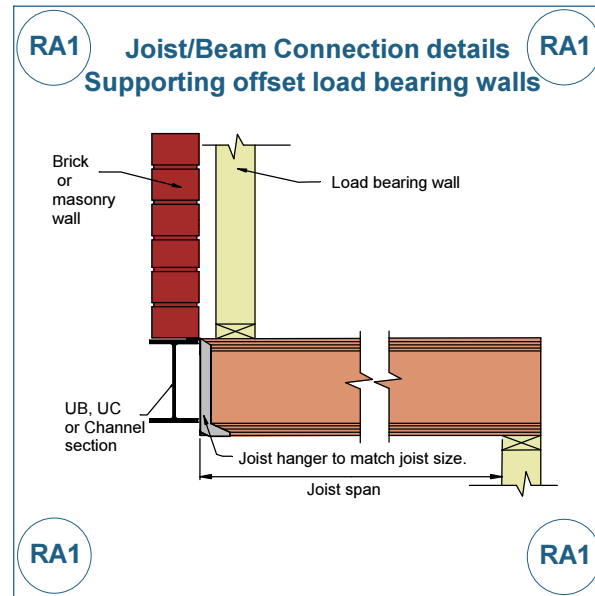

# FLOOR DETAILS: Supporting Load Bearing & Non-Load Bearing cantilever details

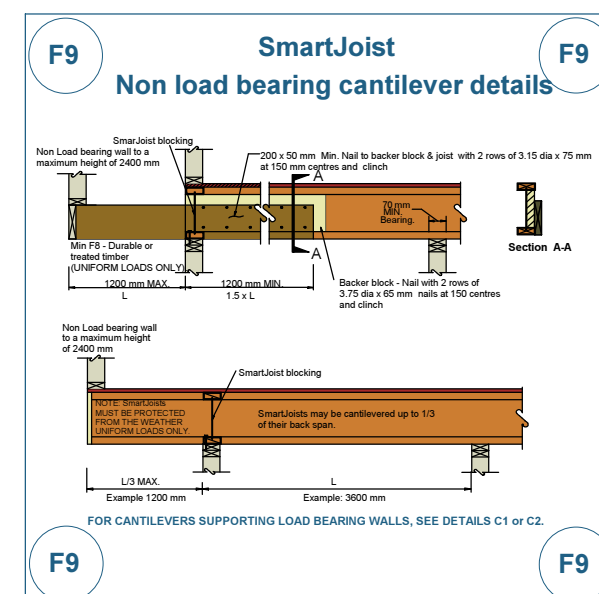
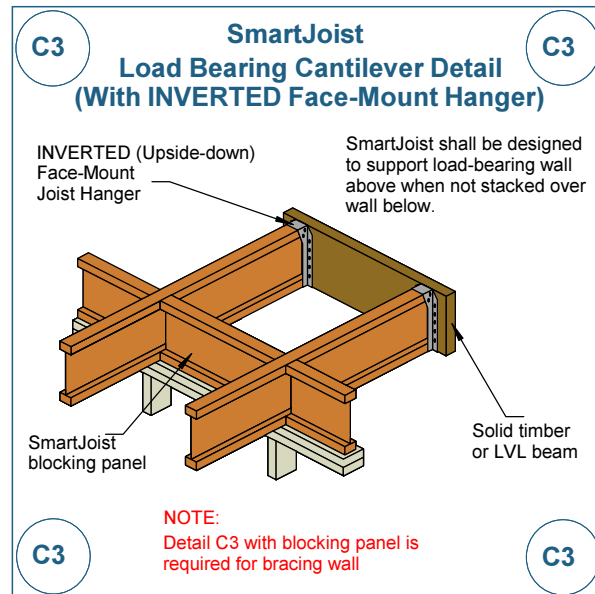
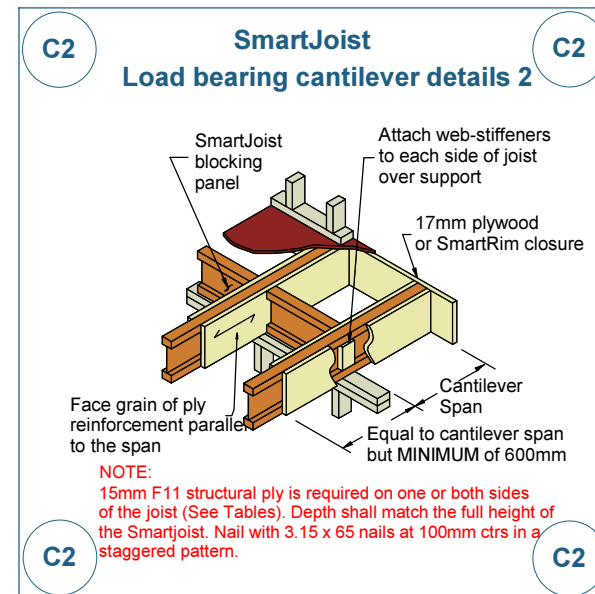
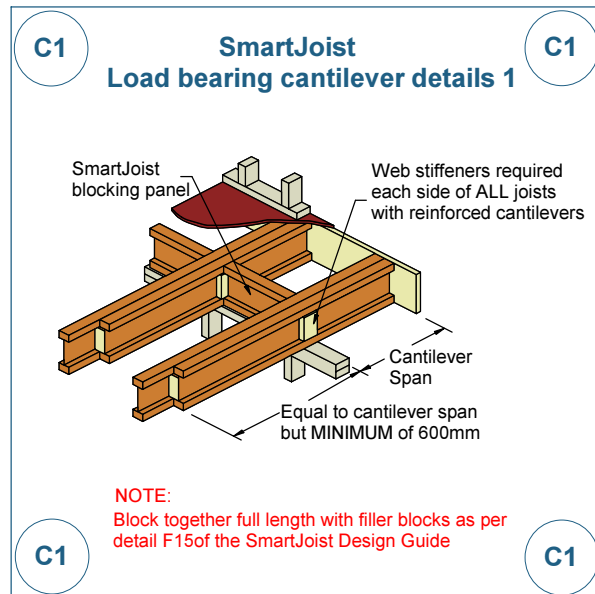

# FLOOR DETAILS: SmartJoist Supporting external/internal LBW details

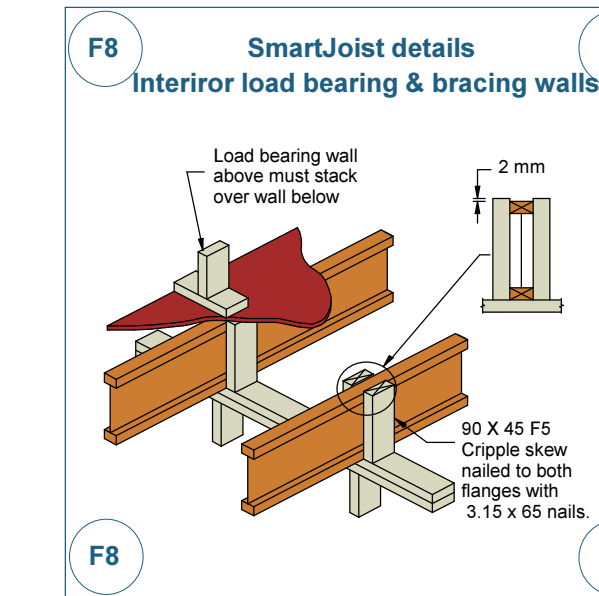
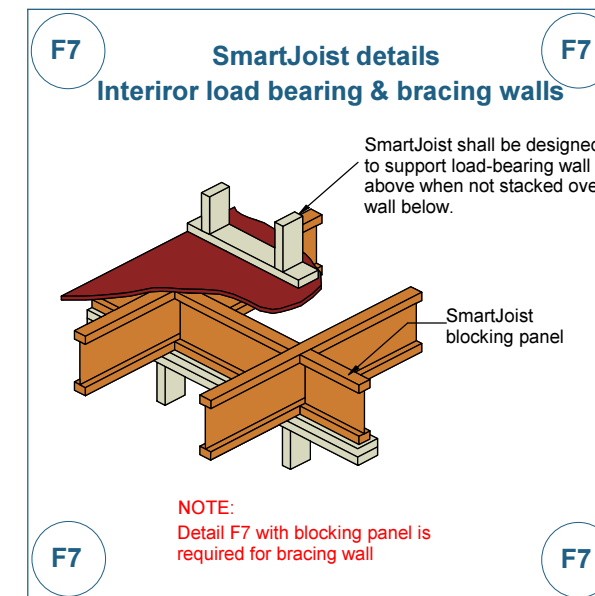
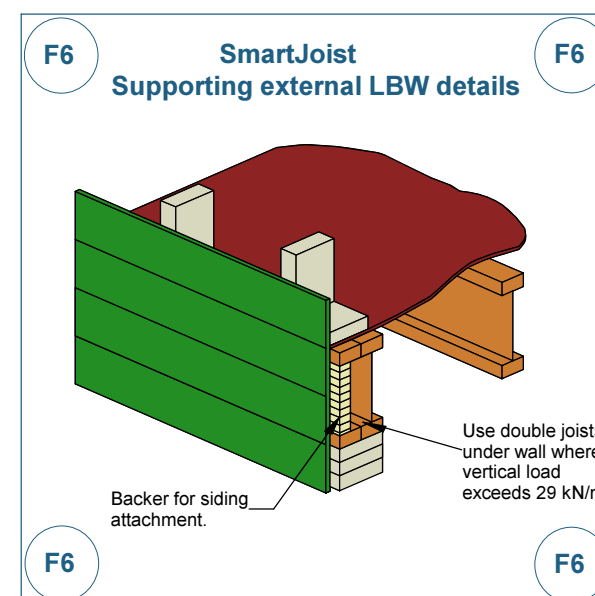
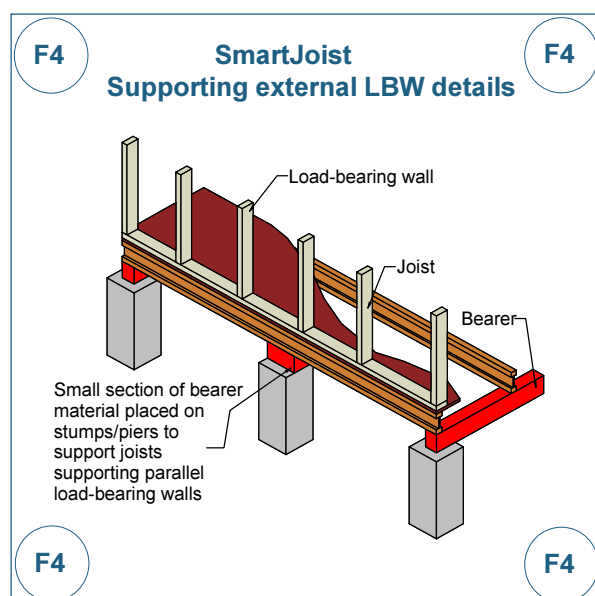

# FLOOR DETAILS: Laminating details & Protectadeck details

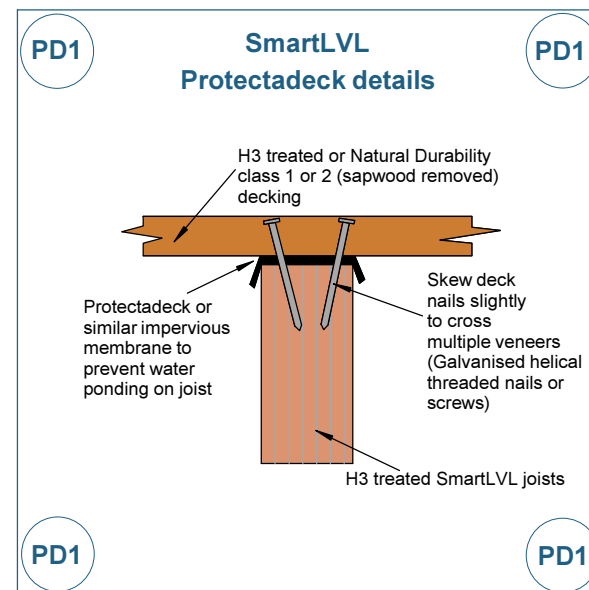
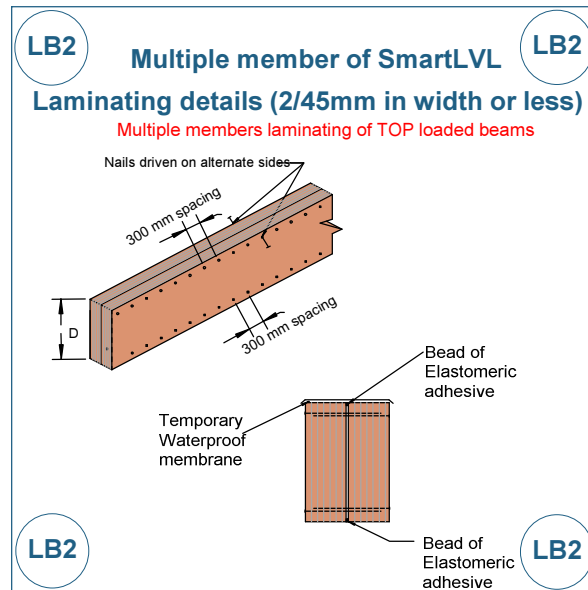
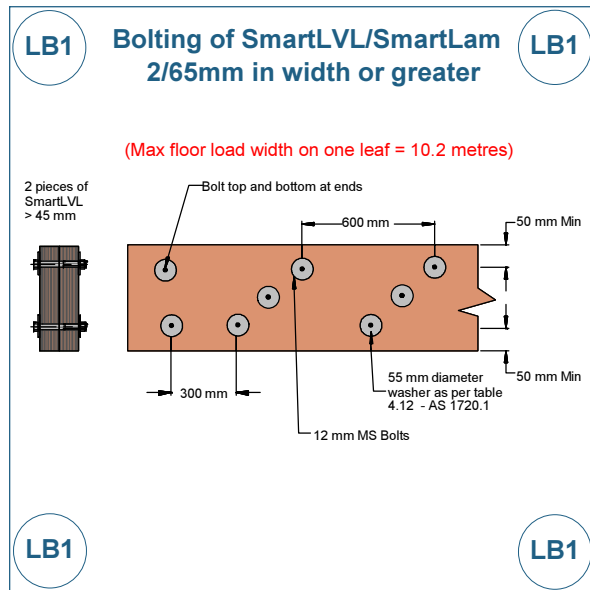

# FLOOR DETAILS: Packer block, I-Joist to I-Joist & I-Joist to Solid Timber Details

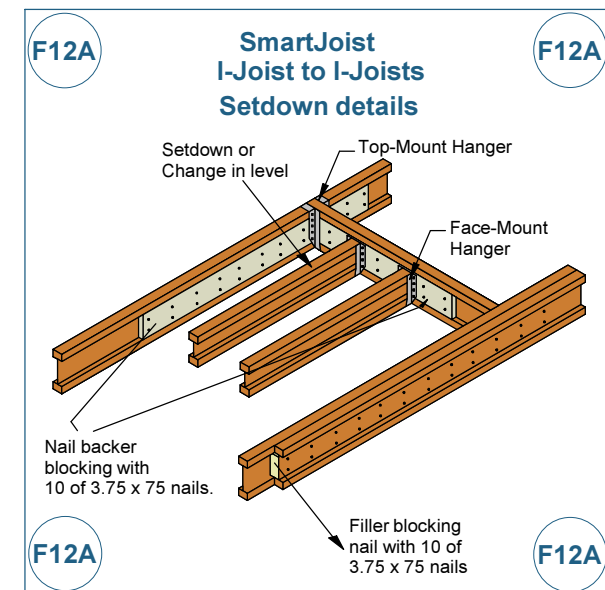
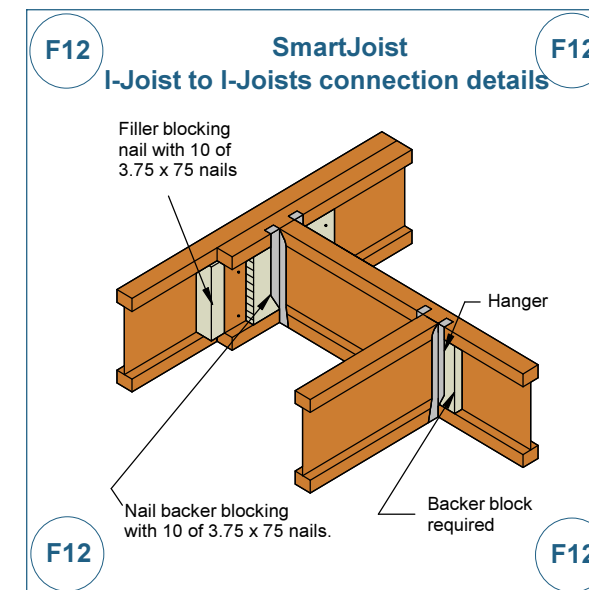
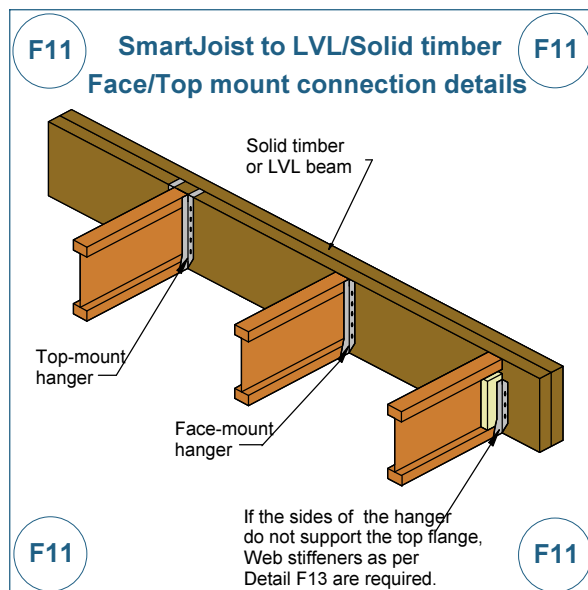
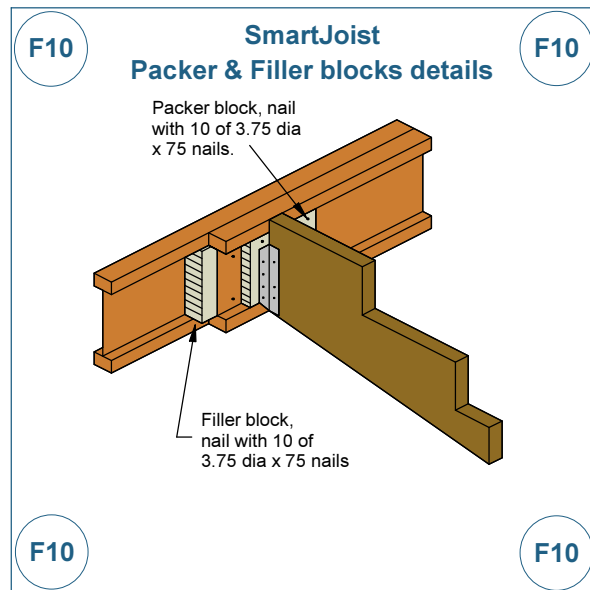

# FLOOR DETAILS: Web stiffeners, Bevel cut & Multiple SmartJoist details

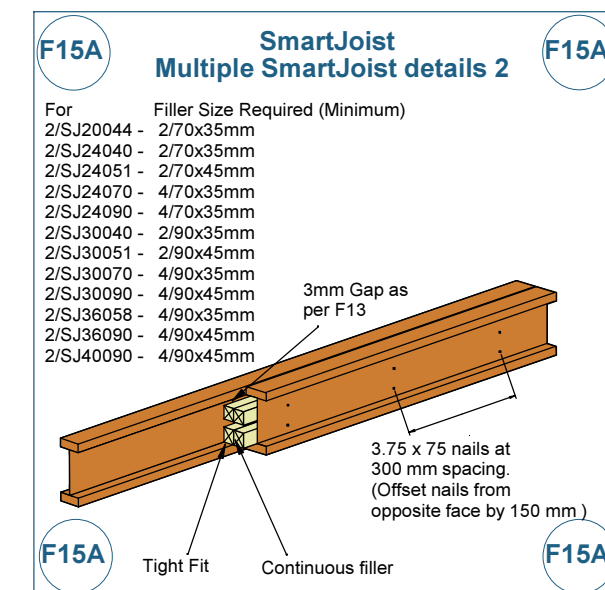
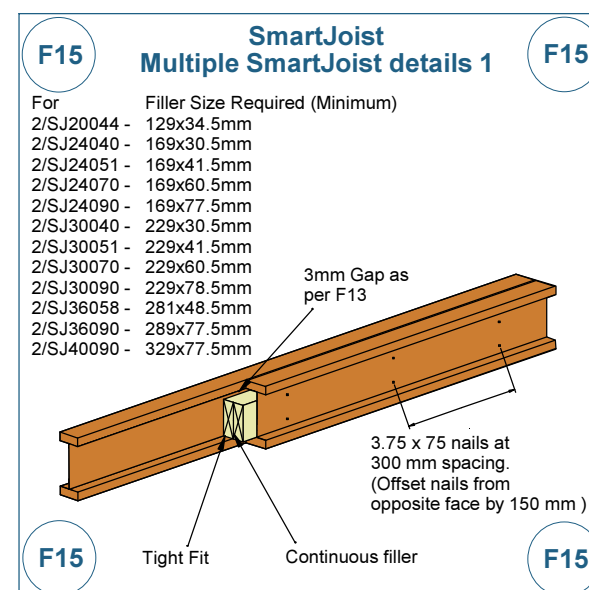
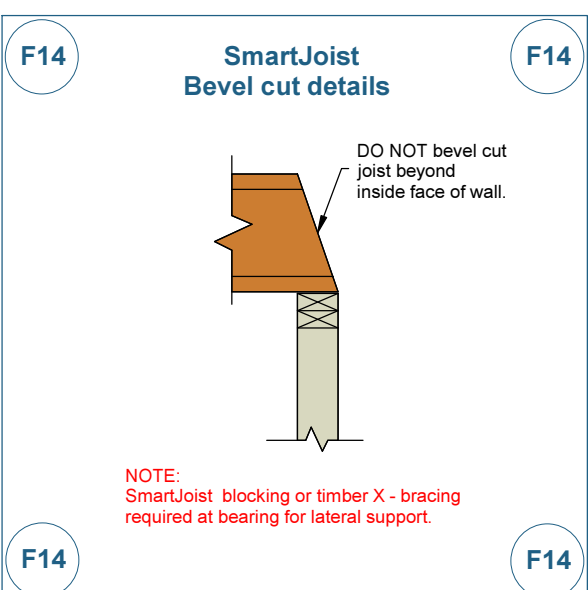
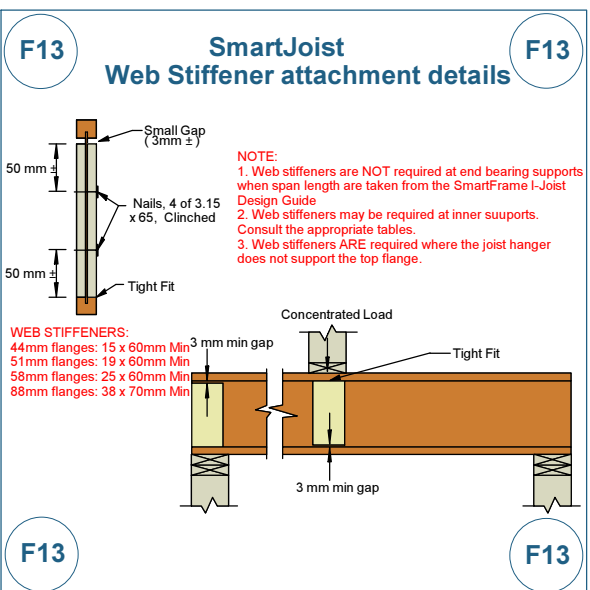

## FLOOR DETAILS: Blocking & Rimboard details

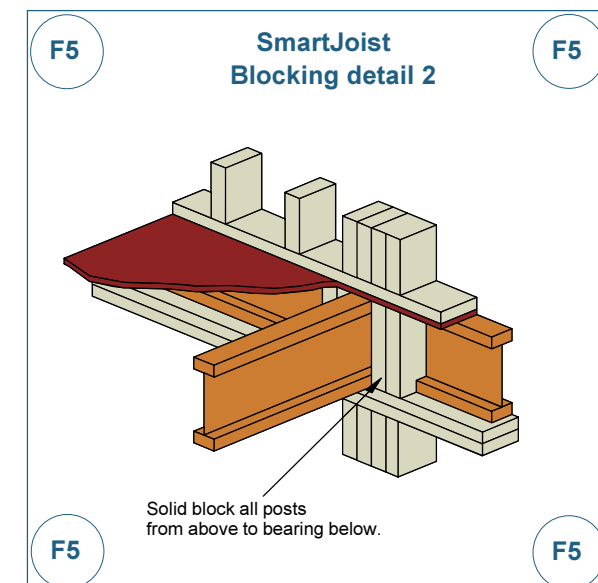
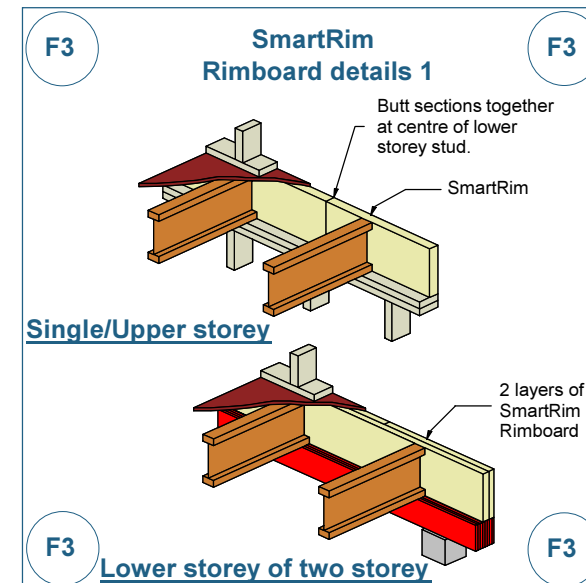
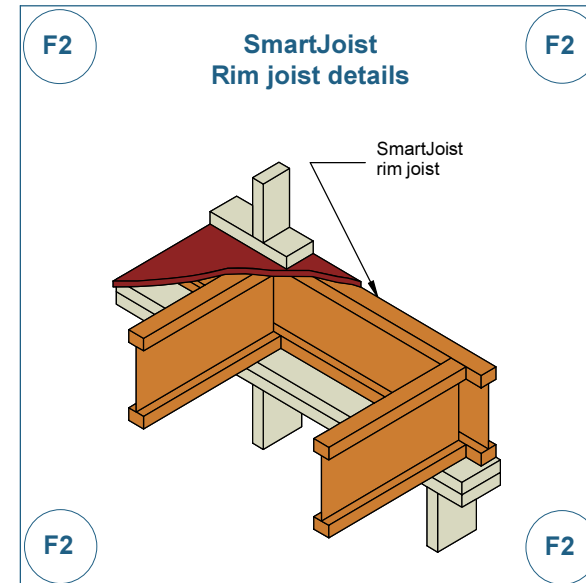
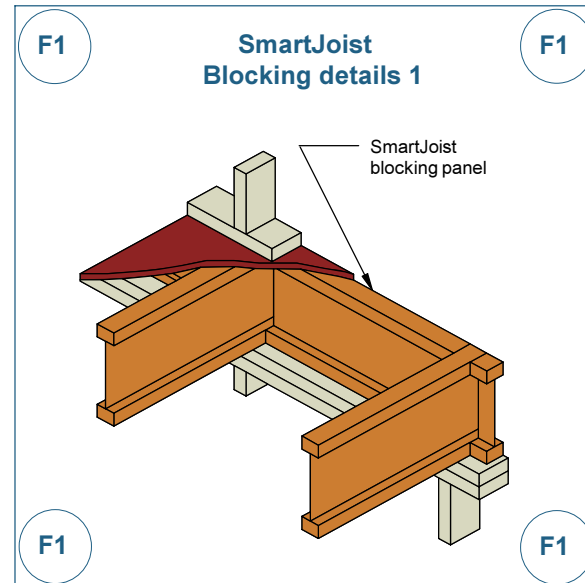

## FLOOR DETAILS: I-Joist to Solid Timber & I-Joist to BrickWall Details

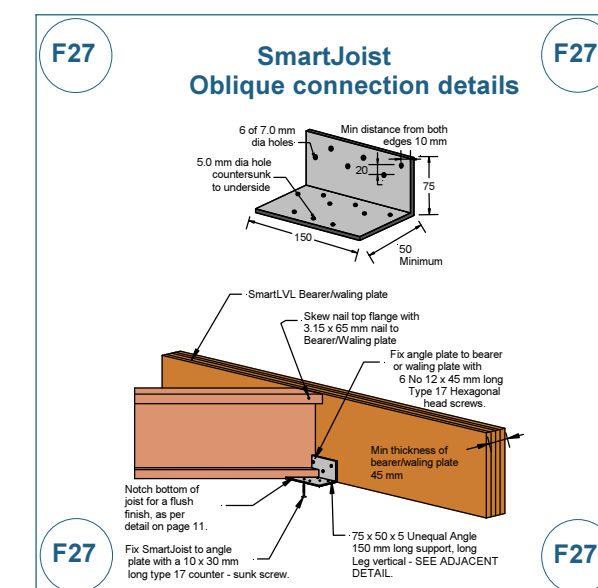
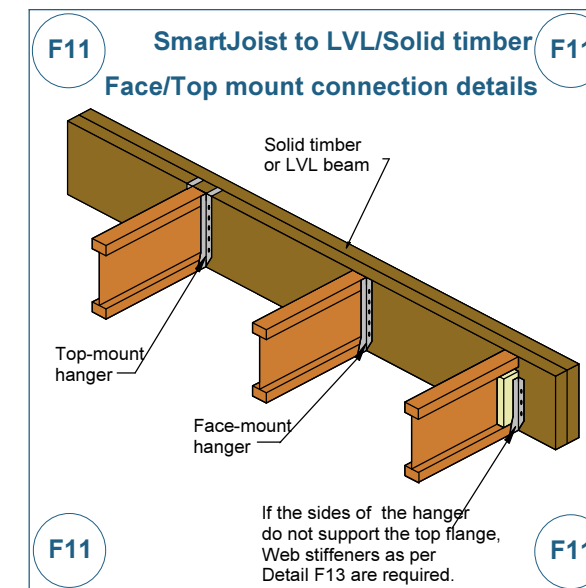
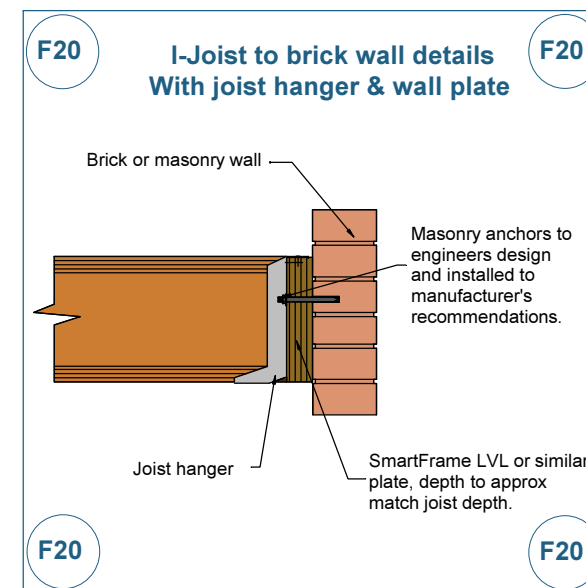
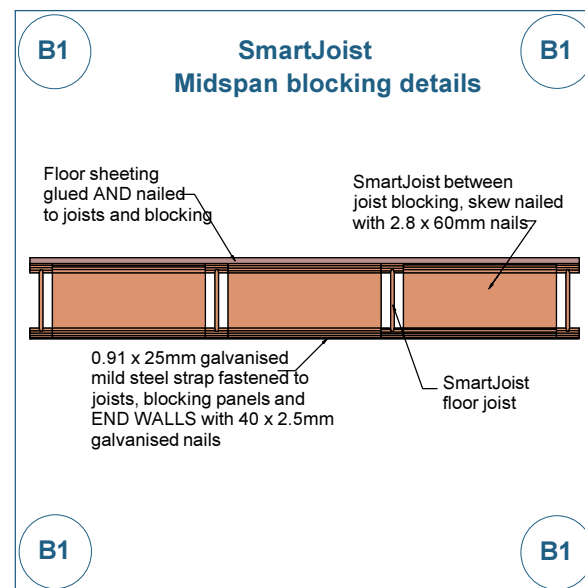

## FLOOR DETAILS: SmartJoist to Steel Details (With Hanger)

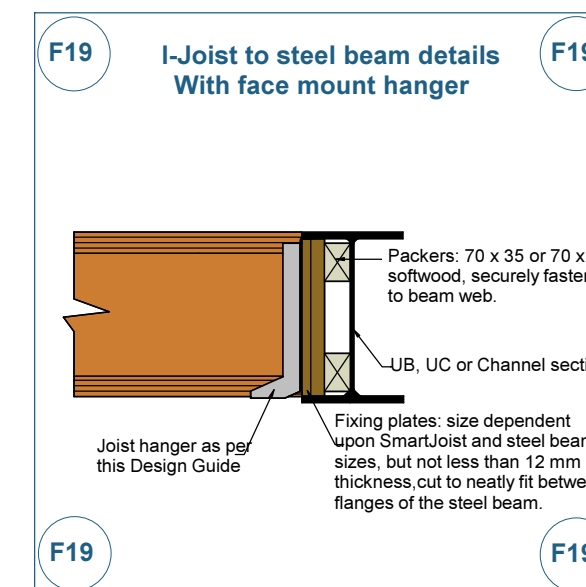
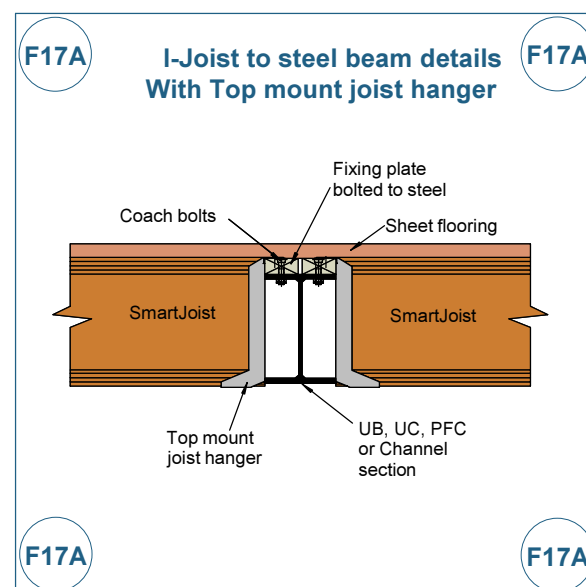
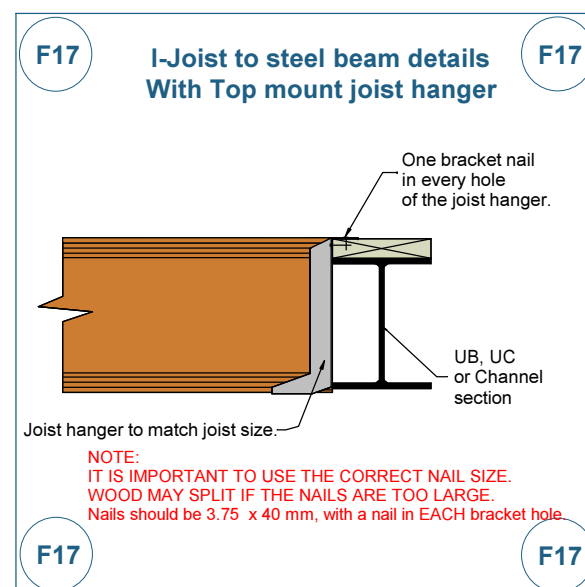

# FLOOR DETAILS: SmartJoist to Steel Details (Without Hanger)

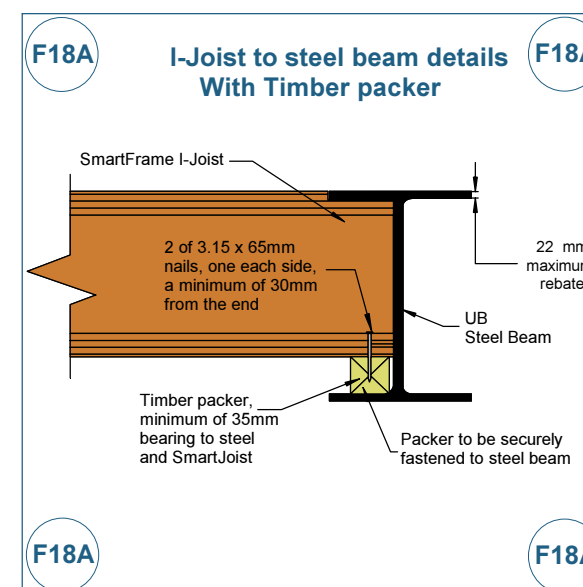
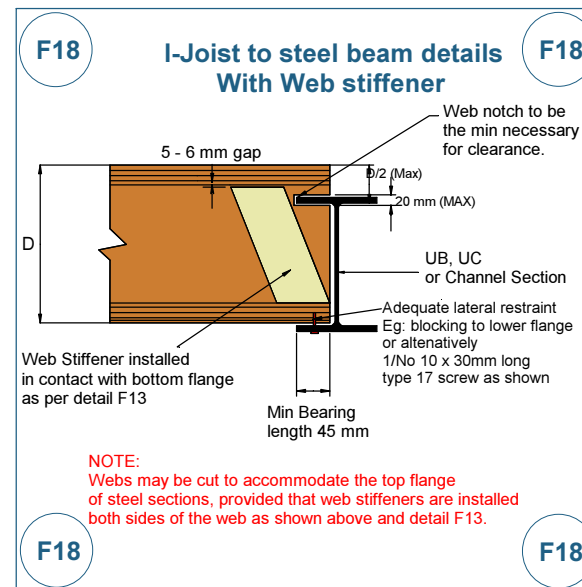
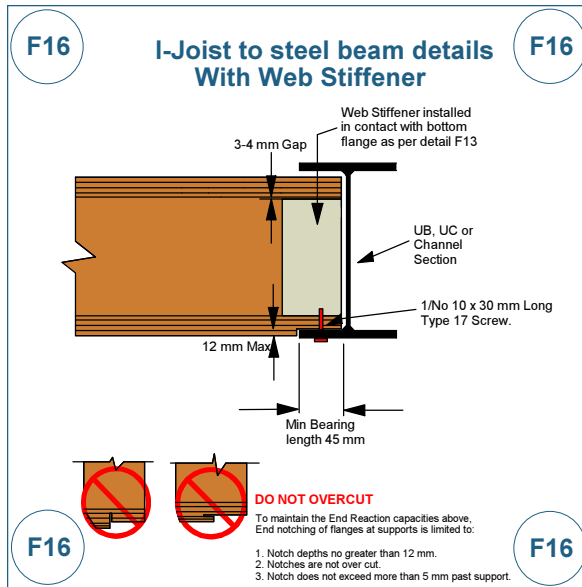

# FLOOR DETAILS: Brick ledge cantilever details

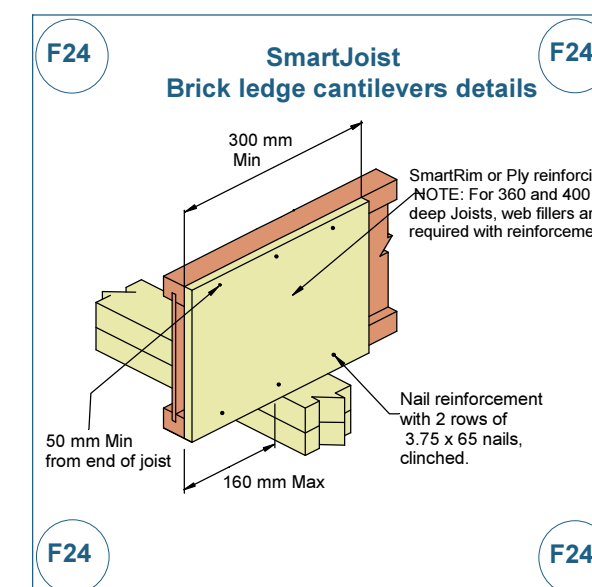
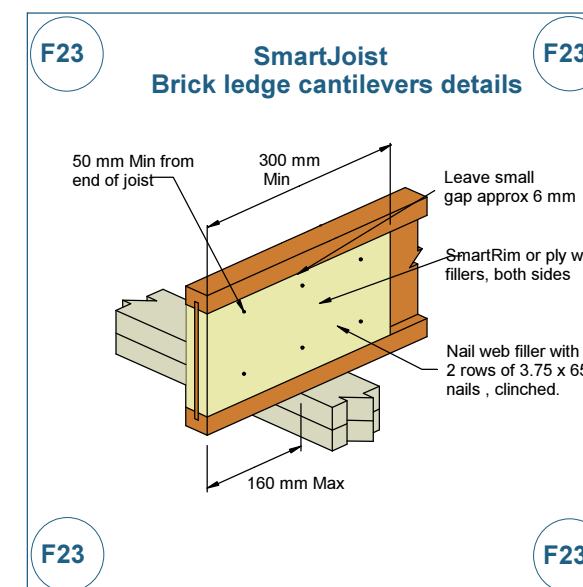
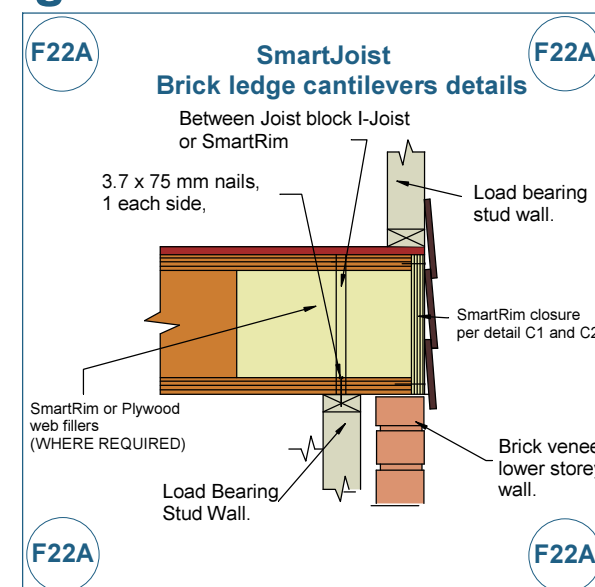
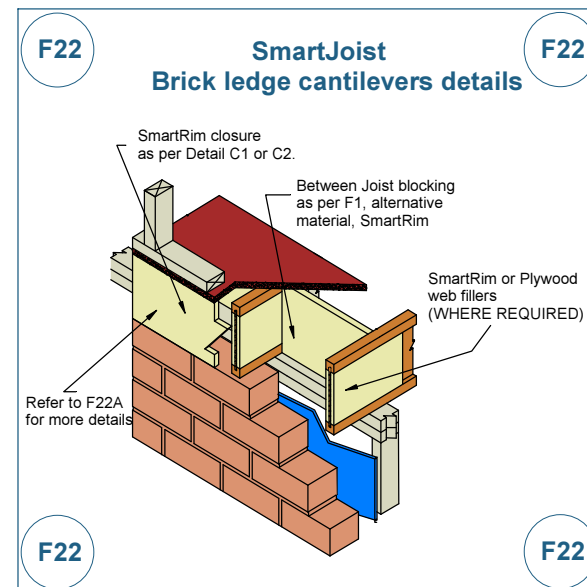

# FLOOR DETAILS: SmartJoist Tie-Down details

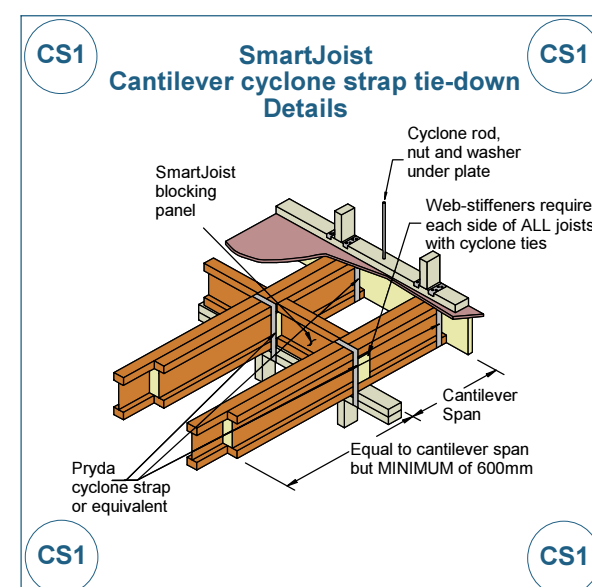
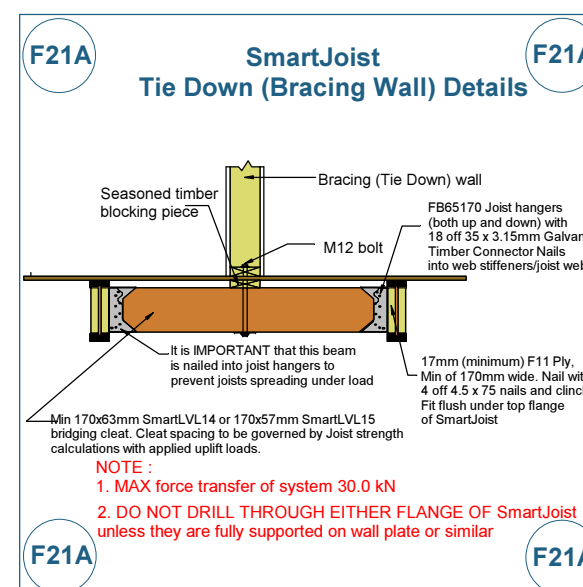
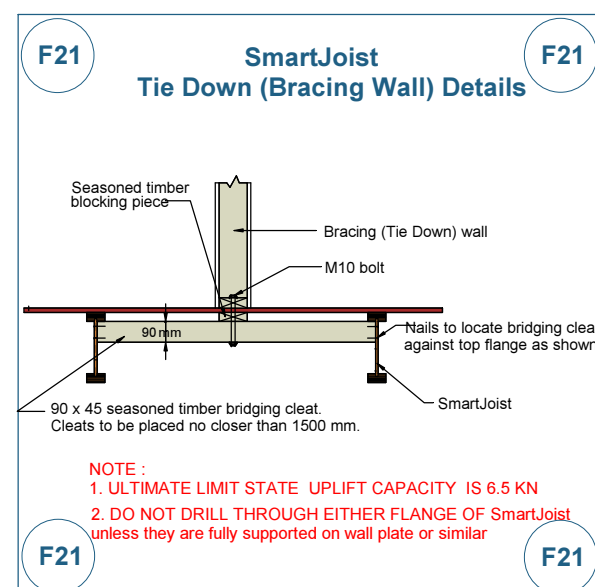
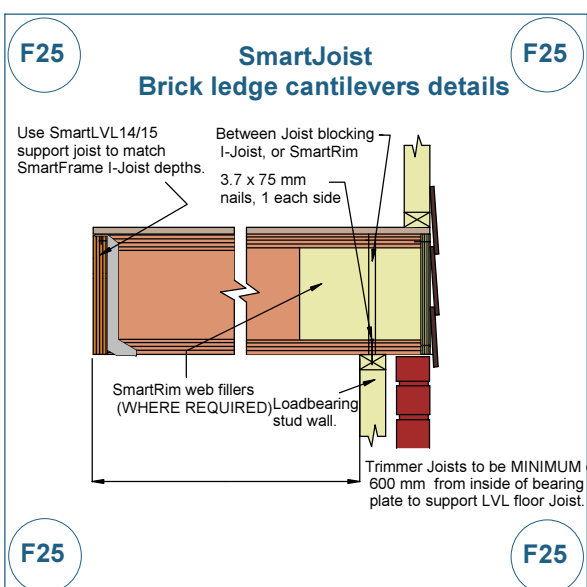

# TYPICAL ROOF DETAILS

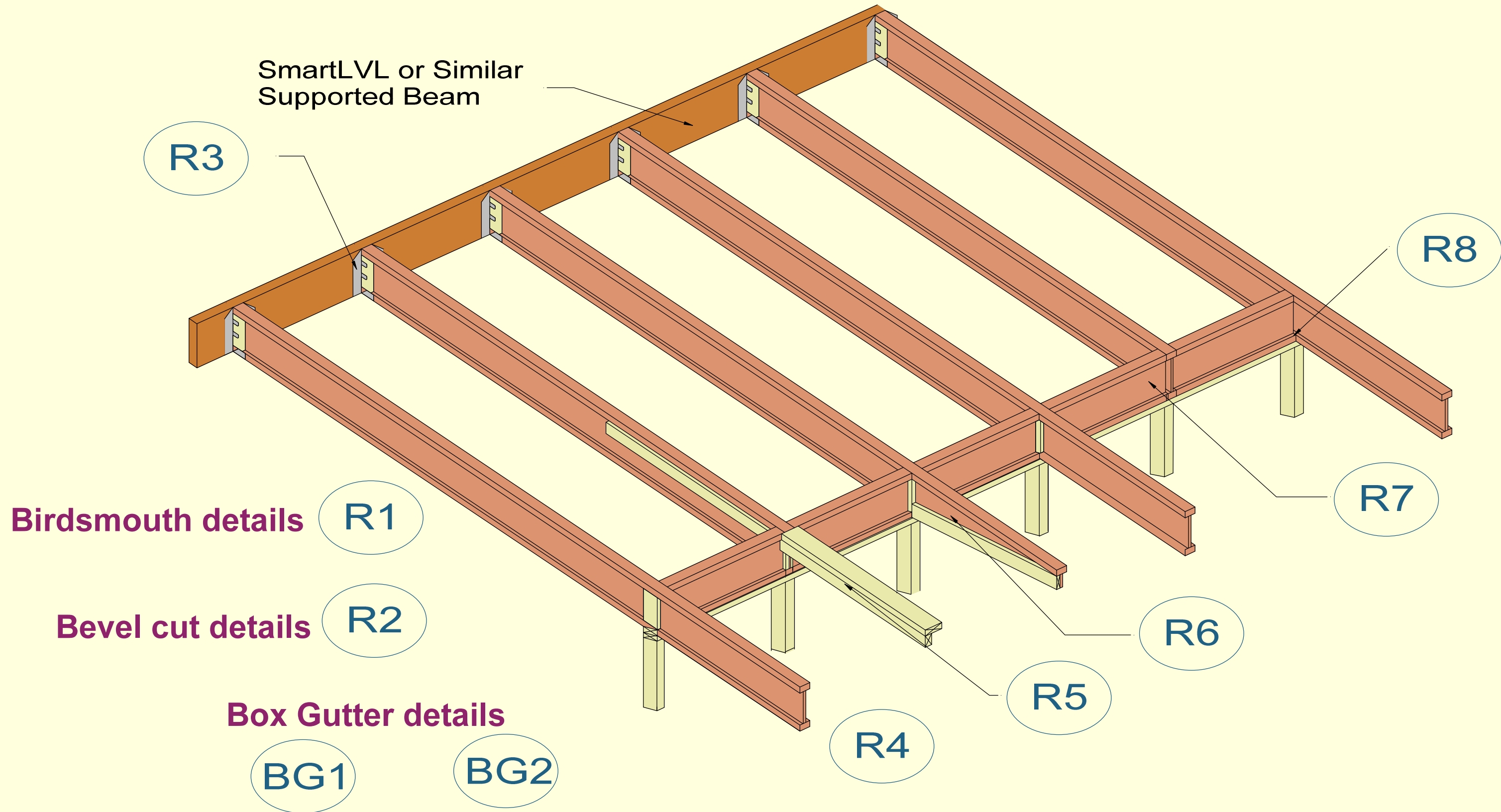

# ROOF DETAILS: Box-Gutter details

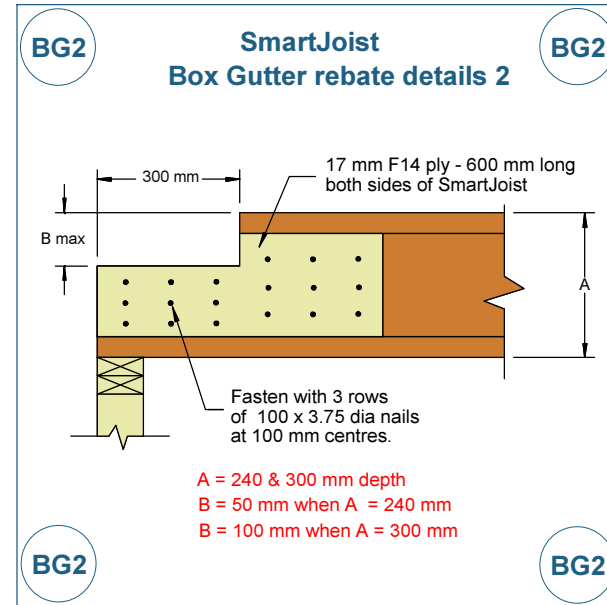
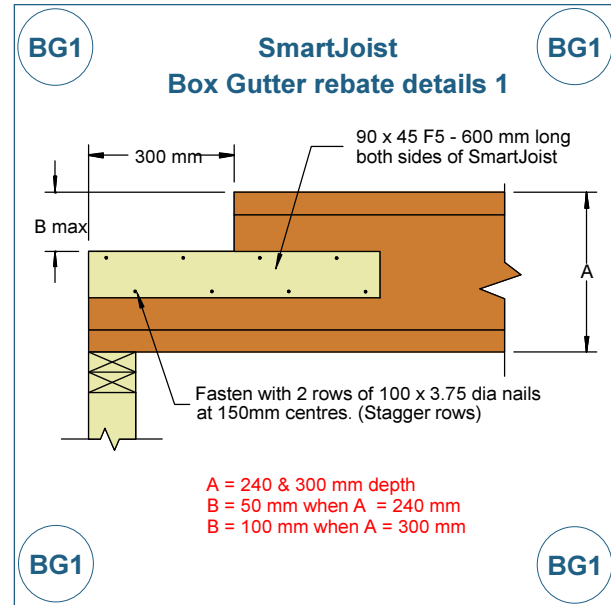

# ROOF DETAILS: Rafter cut details

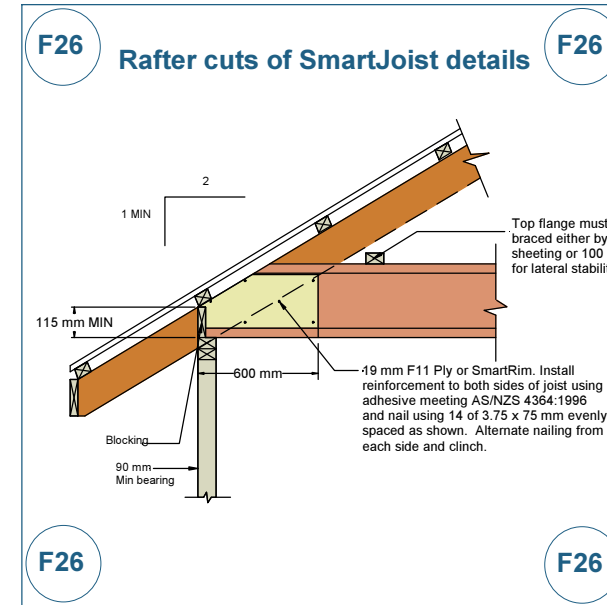

# ROOF DETAILS: R1-R8 details

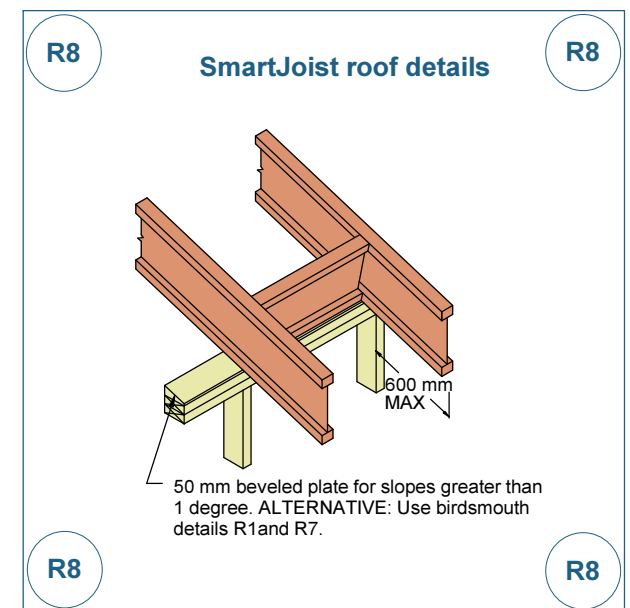
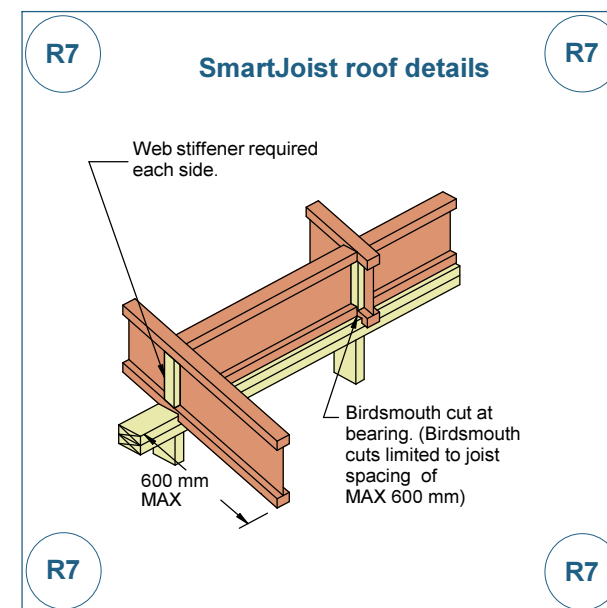
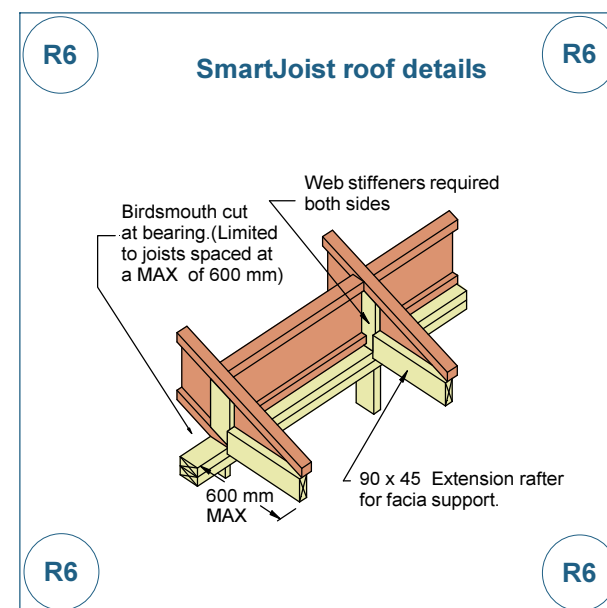
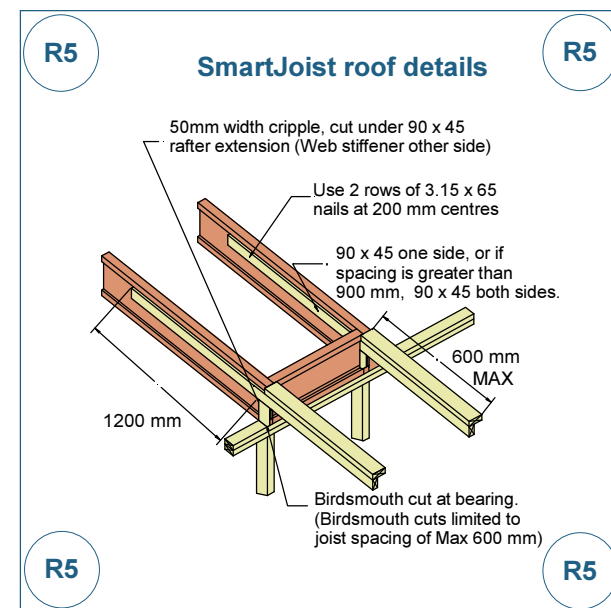
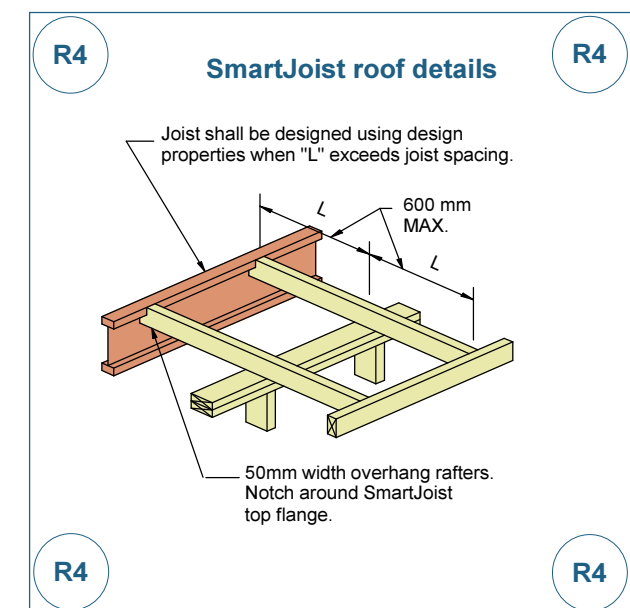
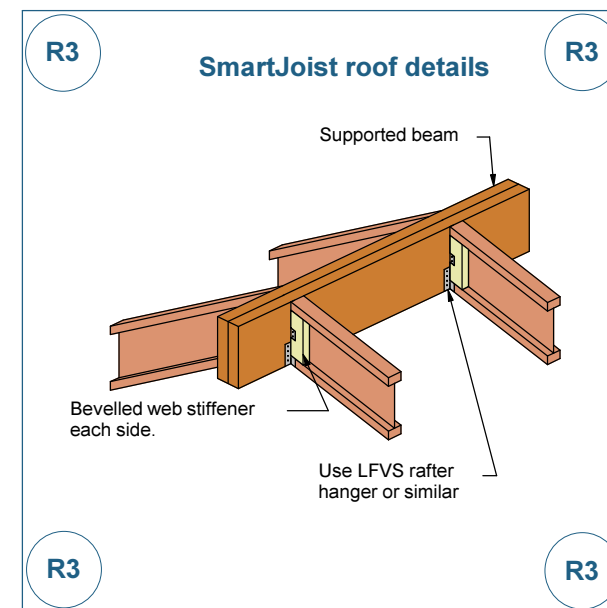
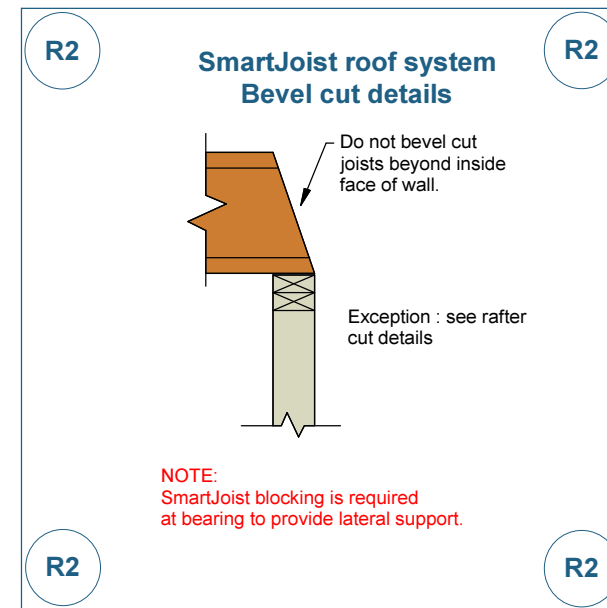
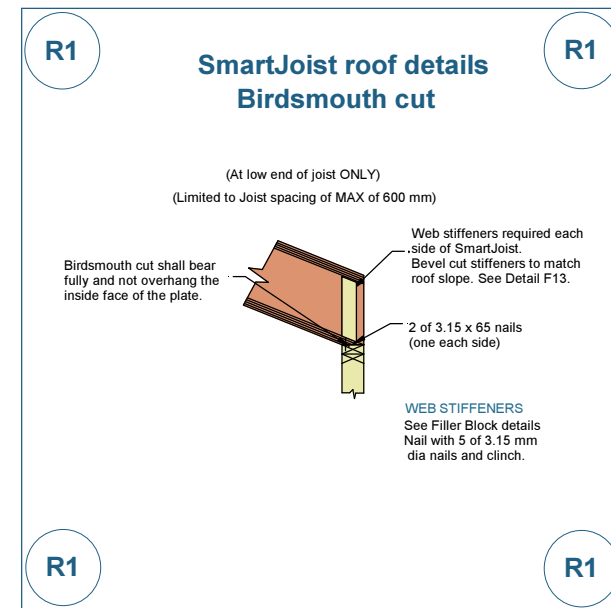

# ROOF DETAILS: R1-R8 details (Cont'd)

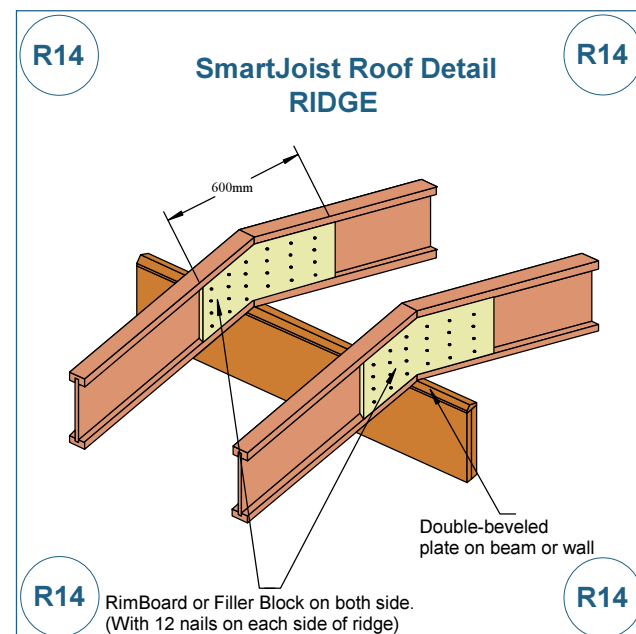
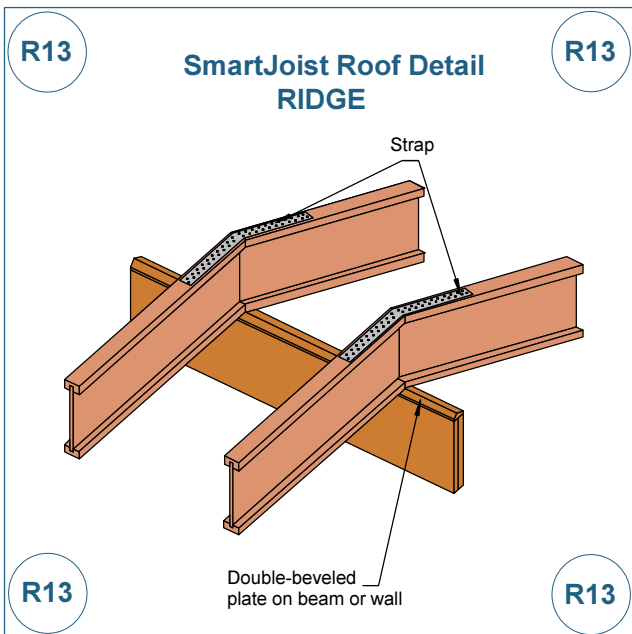
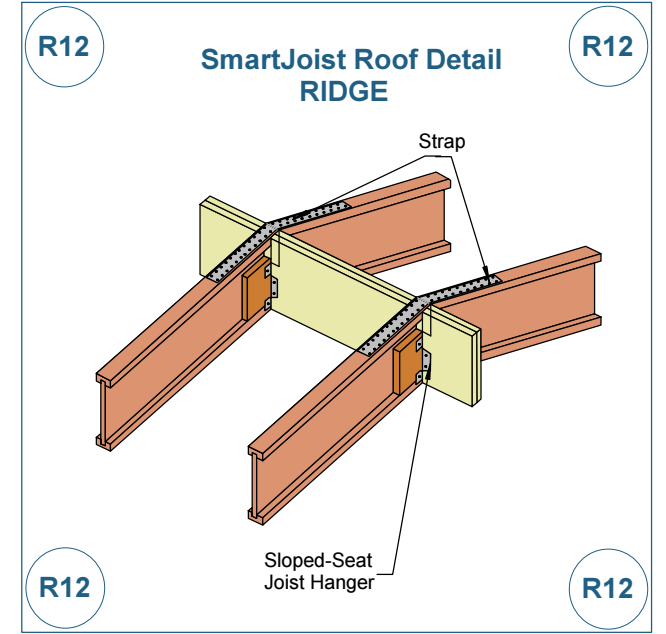
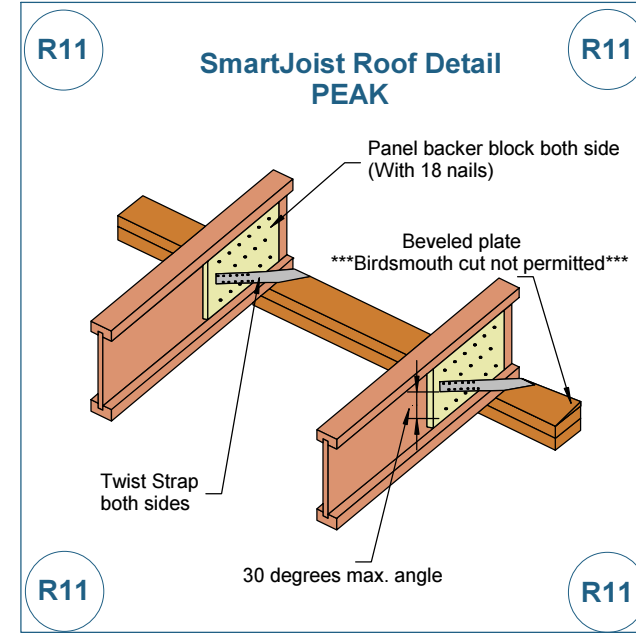
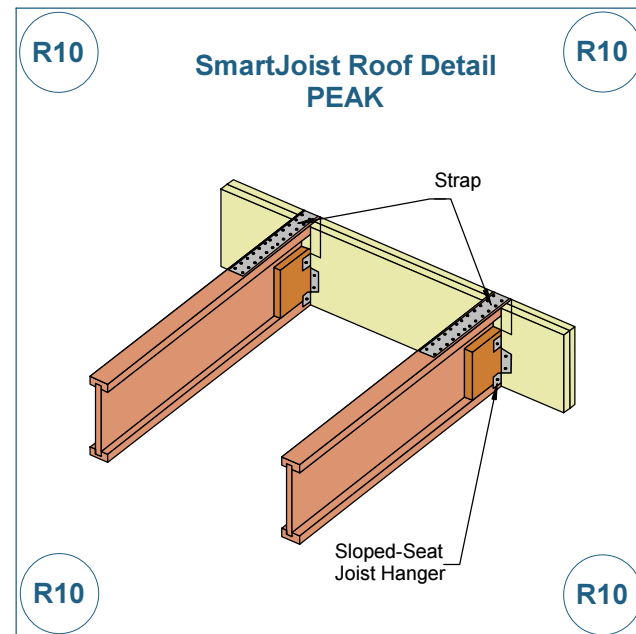
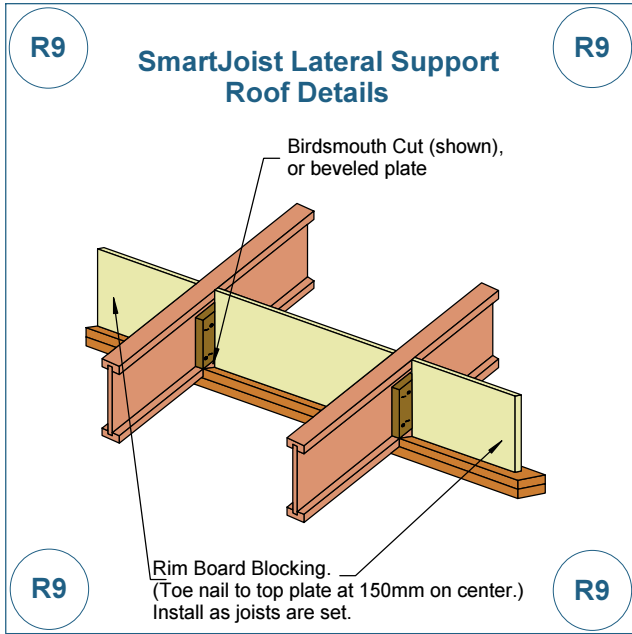

## Decking as Floor Cladding

Balcony's or deck's which have decking over joists should be sized out of H3 treated timber or class 2 materials. Any timber that is in direct contact with the deck or deck ledger plate must also be H3 treated. If the deck adjoins on to a frame with brick work running up past the deck, there is no need for a treated structural rimboard.

Any hip bearers that do not run at a true 45 degrees angle must be supplied as a double bearer

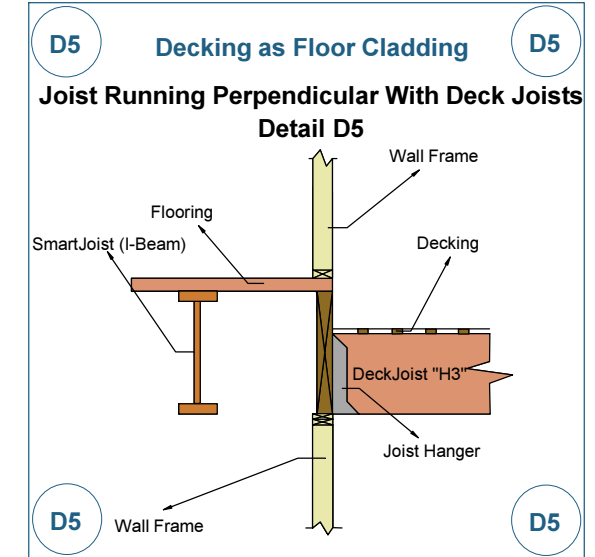
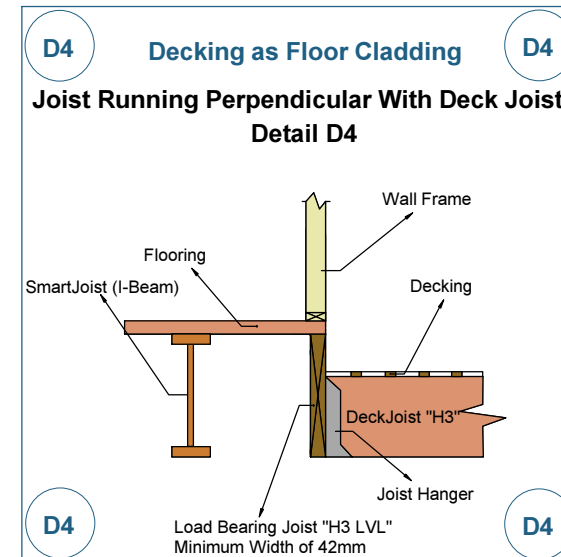
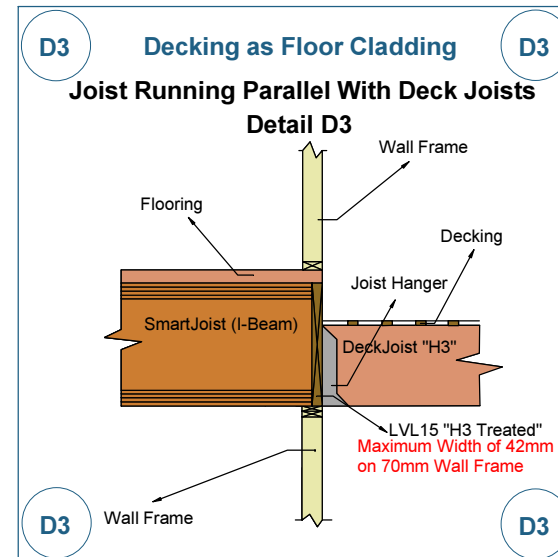
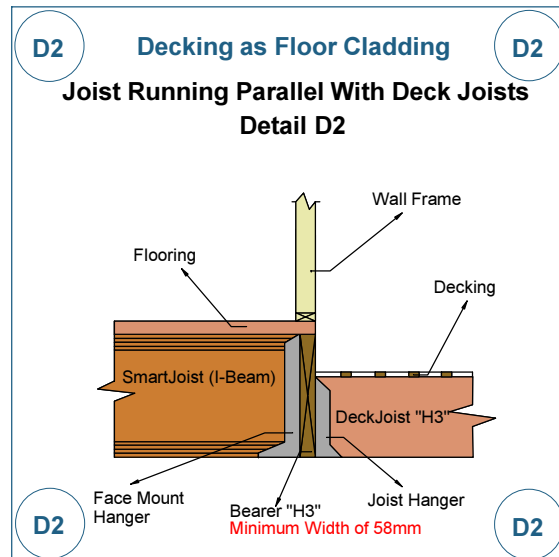
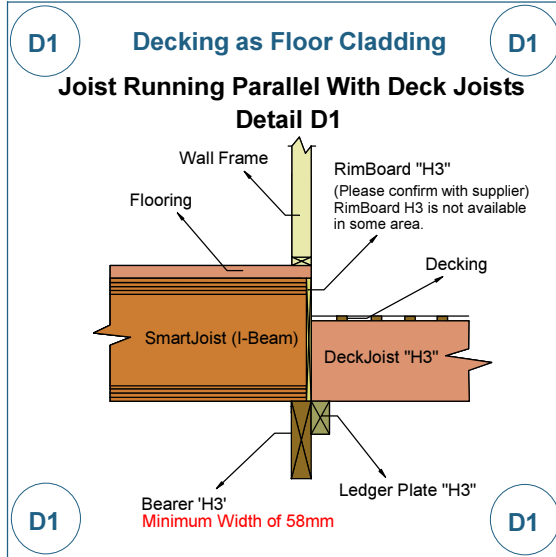

## Tiles as Floor Cladding

Balcony's and deck's which have tile cladding over joists with a ceiling under should be sized out of F7 CCA pine, MGP12 pine, I-Beams, LVL or F27 material. The minimum joist width should be 45mm to allow for the fixing requirements of Compresses FC sheets

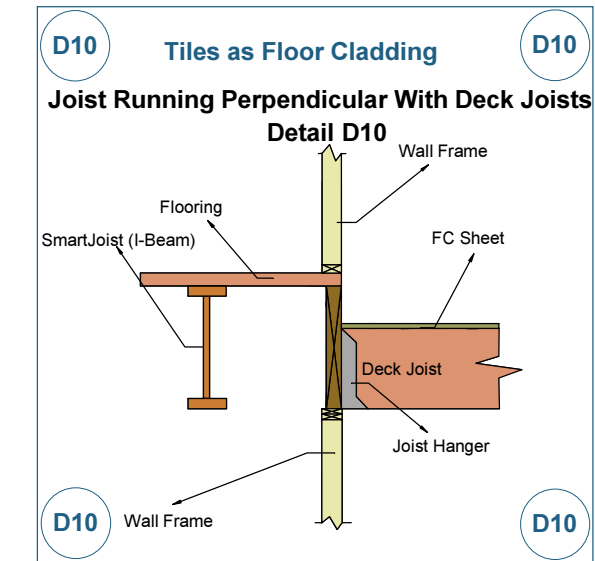
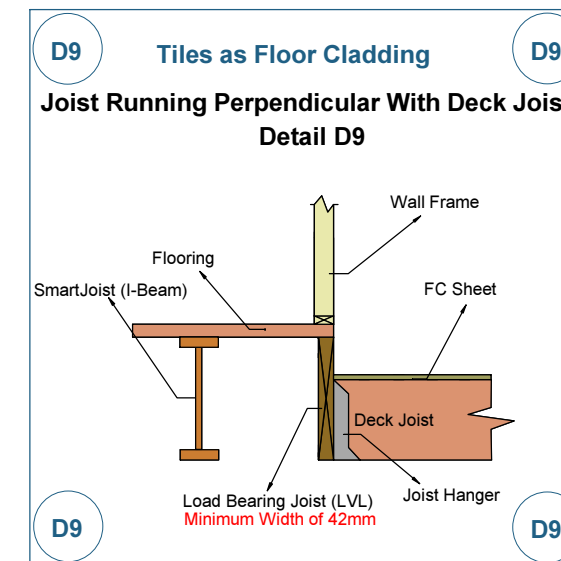
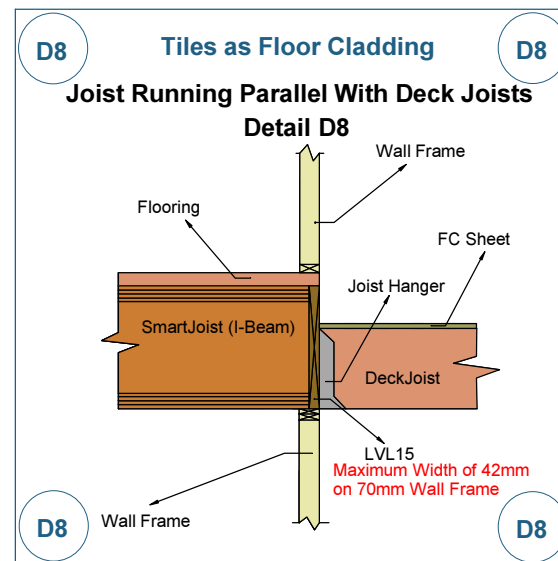
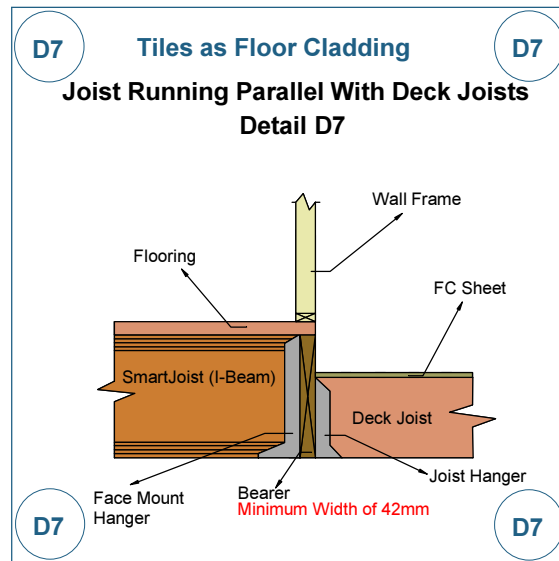
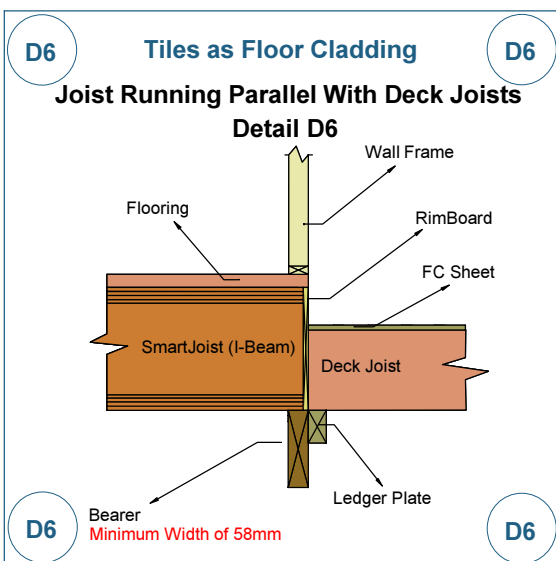

# Bearing Details

**BD1** **Beam-To-Beam Connection Bearing Detail** **BD1**

Make sure hanger capacity is appropriate for each application. Hangers must be properly installed to accommodate full capacity.

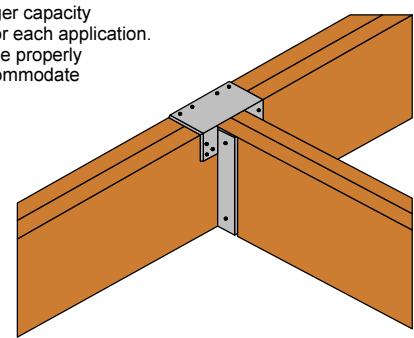

**BD1** **BD1**

This diagram shows two wooden beams meeting at a right angle. A metal hanger is used to connect them, with one end of the hanger passing through the top of one beam and the other end passing through the top of the other beam. The hanger is secured with nuts and washers.

**BD2** **Beam-To-Beam Connection Bearing Detail** **BD2**

Verify the required bearing area and the ability of the supporting column member to provide adequate strength.

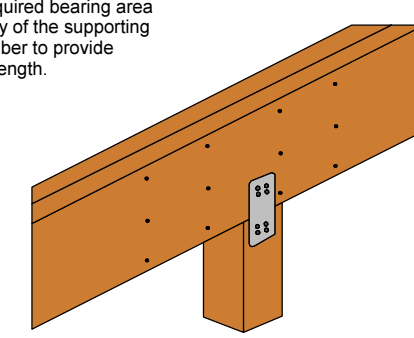

**BD2** **BD2**

This diagram shows a wooden beam resting on a vertical supporting column. A metal hanger is used to connect the beam to the column, with one end of the hanger passing through the top of the beam and the other end passing through the side of the column. The hanger is secured with nuts and washers.

**BD3** **Beam-To-Beam Connection Bearing Detail** **BD3**

Verify the required bearing area and the ability of the supporting column member to provide adequate strength.

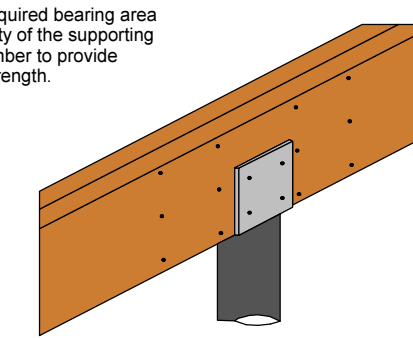

**BD3** **BD3**

This diagram shows a wooden beam resting on a vertical supporting column. A metal hanger is used to connect the beam to the column, with one end of the hanger passing through the top of the beam and the other end passing through the top of the column. The hanger is secured with nuts and washers.

**BD4** **Bearing on Exterior Wall Bearing Detail** **BD4**

Prevent direct contact of LVL products with concrete. Consult local building code for requirement

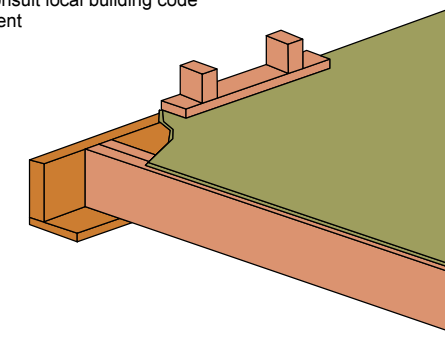

**BD4** **BD4**

This diagram shows a wooden beam resting on a concrete exterior wall. A metal hanger is used to connect the beam to the wall, with one end of the hanger passing through the top of the beam and the other end passing through the wall. The hanger is secured with nuts and washers. A green layer is shown between the beam and the wall to prevent direct contact.

**BD5** **Bearing For Door/Windows Header - (1-Story Typical) Bearing Detail** **BD5**

See "Bearing Length Requirements" For more details

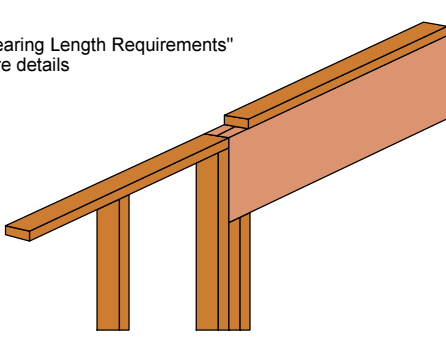

**BD5** **BD5**

This diagram shows a wooden header resting on two vertical posts. The header is supported by the posts, and the posts are supported by a foundation.

**BD6** **Bearing For Door/Window Header - (2-Story Typical) Bearing Detail** **BD6**

See "Bearing Length Requirements" For more details

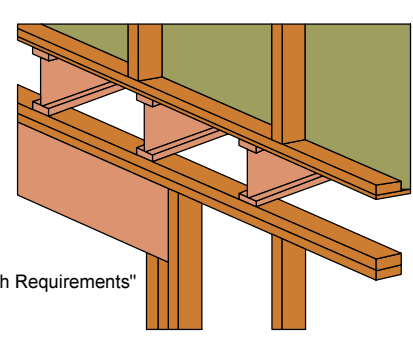

**BD6** **BD6**

This diagram shows a wooden header resting on two vertical posts. The header is supported by the posts, and the posts are supported by a foundation. The header is also supported by a second set of posts above the first set, indicating a two-story structure.