

Smart10 LVL Design Guide



Smart10 LVL Stud Design Guide

Scope of this publication

This Design Guide and Load Tables assist in the selection of Smart10 LVL for a limited number of common structural arrangements met in domestic construction.

Methods of developing lateral restraint and providing adequate support, adequate anchorage against wind uplift, and overall structural stability are outside the scope of this publication, however some limited examples have been reproduced within this document.

Information on the above matters can be obtained from AS 1684 Residential timber-framed construction or from a structural engineer experienced in timber construction.

Tilling Timber Pty Ltd have structural engineers at the SmartFrame Design Centre who can be contacted for advice on matters concerning the use of its engineered timber products in timber construction at techsupport@tilling.com.au or on the Techsupport Helpline 1300 668 690.

Substitution of other products

All load tables in this document are designed using in-grade tested properties of Smart10 LVL as distributed by Tilling Timber Pty Ltd. Other manufacturers' LVL may have different properties and therefore cannot be designed using these span tables.

Copyright

Copyright of this publication remains the property of Tilling Timber Pty Ltd, and reproduction of the whole or part of this publication without written permission from Tilling Timber Pty Ltd is prohibited.

Certification

As a professional engineer, qualified and experienced in timber engineering, I certify that the use of the Smart10 LVL members as shown in these tables, and installed in accordance with the provisions of this Design Guide, complies to the National Construction Code (NCC). These span tables have been prepared in accordance with standard engineering principles, the relevant test reports and Australian standards, ie:

- AS 1720.3 Design criteria for timber-framed residential buildings
- AS 1720.1 Timber structures - design methods
- AS 4055 Wind loads for houses
- AS/NZS 4063 Characterisation of structural timber
- AS/NZS 4357 Structural laminated veneer lumber

Craig Kay

CRAIG KAY, RPEng, BDC0730, PE0001869, RPEQ 05100, CC5635C, NER
National Product Engineer

About Smart10 LVL

Description

Smart10 LVL is a structural Laminated Veneer Lumber (LVL) manufactured exclusively for Tilling Timber by toll manufacturers in conformance to the quality controlled process requirements of AS/NZS 4357 - Structural Laminated Veneer Lumber.

Forest stewardship

Smart10 LVL is manufactured from wood fibre from sustainably managed plantation forests and is produced under a PEFC certified chain of custody system. CFCC GB/T 28952-2018, PEFC SAT 2002:2013.

Product certification

Quality



CMI ProdCert

Compliance with process based quality control requirements is third party audited by CMI Certification, and the audits, together with end product testing is used as the basis for Product Certification by CMI ProdCert as a JAS-ANZ accredited Product Certification body.

JAS-ANZ stands for the government established "Joint Accreditation System of Australia and New Zealand" which exists as the peak organisation for accreditation of Product Certification bodies.



Preservative Treatment options

Smart10 LVL is supplied with H2s glue-line preservative treatment for use South of the Tropic of Capricorn or SmartGuard H2 or H3 post production pressure treatment, with all treatments in conformance to AS/NZS 1604.1:2021.

Sustainability

Wood is the right choice for a host of construction applications. It is the earth's natural, energy-efficient, and renewable building material. The miracle in today's engineered wood products is that they make more efficient use of the wood fibre resource to make stronger Plywood, Oriented Strand Board (OSB), I-joists, Glued Laminated Timber (GLT) and Laminated Veneer Lumber (LVL). That is good for the environment and good for designers seeking strong, efficient, and striking building design.

For every tonne of wood grown, a young forest produces 1.07 tonnes of oxygen and absorbs approximately 1.47 tonnes of carbon dioxide. This is good news for a healthy planet. Wood is a perfect material for the environment, for design, and for strong, lasting construction.



The information contained in this product brochure is current as at March 2024 and is based on data available to Tilling Timber Pty Ltd at the time of going to print. Tilling Timber Pty Ltd has used its reasonable endeavours to ensure the accuracy and reliability of the information contained in this document and, to the extent permitted by law, will not be liable for any inaccuracies, omissions or errors in this information nor for any actions taken in reliance on this information. Tilling Timber Pty Ltd reserves the right to change the information contained in this document without prior notice. It is important that you call the techsupport Helpline on 1300 668 690 to confirm that you have the most up to date information available.

Durability and exposure to moisture

Storage and handling of Smart10 LVL

- Store Smart10 LVL flat on a hard, dry surface
- If surface isn't paved, the ground should be covered with a polythene film
- Keep covered with waterproof material that allows bundles to "breathe"
- Use bearers (bolsters) between the ground and the first bundle (4 metre max spacing)
- Use 100 x 50 timber flat between bundles at same spacing as bolsters
- Take great care to rewrap remaining material after opening bundles
- LVL "grows" in thickness and depth when allowed to get wet....KEEP DRY!
- LVL with high MC has short term reduction in Characteristic Strengths KEEP DRY!
- Under NO circumstances is stored SmartLVL to be in contact with the ground.

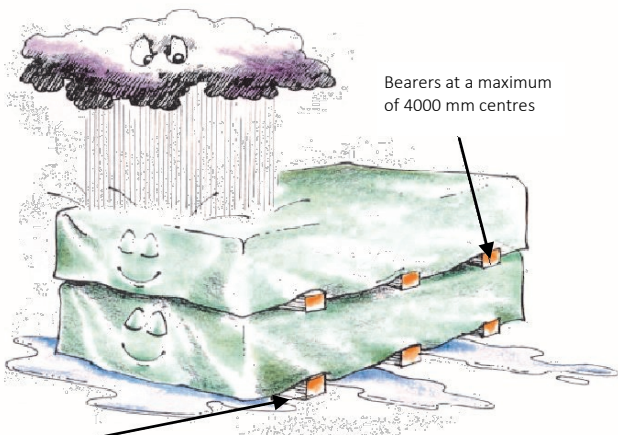

Use bearers to keep stacked material away from damp surfaces. Align bearer vertically

Smart10 LVL is manufactured from veneers which have a natural durability rating of class 4, which is the same rating as some Ash type Eucalypts. Untreated Smart10 LVL should not be used where the equilibrium moisture content is likely to remain above 20% for an extended period.

Non-preserved treated, H2f and H2 preservative treated Smart10 LVL is suitable as studs in the **internal, fully protected, ventilated** and the **external above ground, protected** zones of the structure as shown below. Smart10 LVL is not suitable for **external above ground, exposed** or humid indoor conditions, such as swimming pool enclosures.

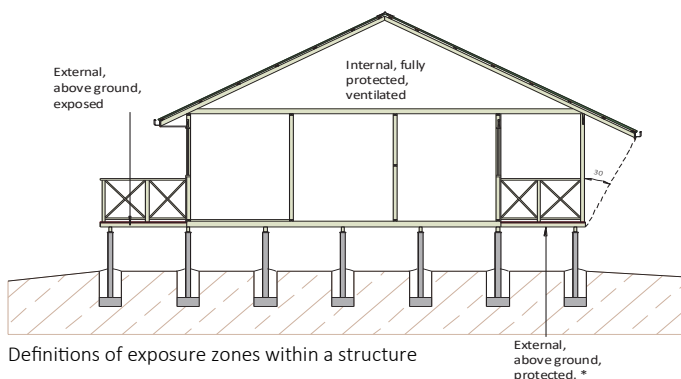

Definitions of exposure zones within a structure

External, above ground, protected.*

Moisture effects on Smart10 LVL

Smart10 LVL, like all wood products, is hygroscopic, which means it has an affinity for water, and being a LVL, should be considered as a composite of many pieces of wood, each with different potential swelling. Moisture exposure will ultimately lead to dimensional change.

Smart10 LVL is supplied with a short term construction water repellent however once framed into a structure may be exposed to the weather for a limited time (usually not greater than 3 months) without negative affect, BUT, it may exhibit some effects of this exposure such as swelling and checking (especially at cut ends), depending upon the weather conditions.

While the products will withstand normal exposure, excessive exposure during distribution, storage or construction may lead to dimensional changes that affect serviceability. These changes include cupping, bowing or expansion to dimensions to beyond the specified tolerance of the product in the "as-manufactured" condition.

Individual members of a laminated multi stud may exhibit some cupping if water becomes trapped between the laminates. This cupping produces more of a visual and possible fixity problem rather than being structurally significant. If not properly dried out, this moisture between laminated members may lead to decay.

As an organic material, mould and mildew may grow on untreated wood products if moisture is present. Prolonged periods of high moisture may also support the growth of wood decay fungi.

In critical applications where dimensional change due to moisture exposure is to be absolutely minimised it is recommended that spray on short term repellent (or bulk for airless spray guns) be used to seal any cut ends or notches etc.

The table below shows the moisture content of LVL as a function of humidity.

Moisture content of wood products % ⁽¹⁾	
Relative Humidity %	LVL MC
10	1.2
20	2.8
30	4.6
40	5.8
50	7.0
60	8.4
70	11.1
80	15.3
90	19.4

1. Approx. moisture content at 21°C

Dimensional change

Smart10 LVL will shrink and swell in proportion to changes in moisture content between 0 and 28 % fibre saturation point.

The most significant moisture movement will occur across the grain (tangential and radial directions within a log). Longitudinal (movement in the grain direction) may be a factor depending upon the type of structure. Detailing of Smart10 LVL to be used where moisture contents will cycle should allow for dimensional instability.

The AVERAGE amount of dimensional change in a piece of Smart10 LVL changes in moisture content can be APPROXIMATED by the following formula:

$$\Delta D = D_i S (MC_i - MC_f) / FSP$$

Durability and exposure to moisture (Cont'd)

Where:

ΔD = change in dimension

D_i = Initial dimension

S = Shrinkage coefficient = approximately 6%

MC_i = Initial moisture content

MC_f = final moisture content

FSP = fibre saturation point approximately 28%

HOWEVER, these dimensional effects are quite variable. Thickness swell in LVL is erratic along the length because of the densification of the lap joints during manufacture tends to "relieve" when saturated and the total swell in sections containing two (2) laps can be as much as 3 mm.

Change in characteristic strengths

Changes in moisture content in wood results in changes in mechanical properties, with higher properties at lower moisture contents. Estimates of the effect of moisture differentials on the properties of clear wood may be obtained by the following equation:

$$P = P_{12} \left(\frac{P_{12}}{P_g} \right)^{\left(\frac{12 - M}{M_p - 12} \right)}$$

Where:

P = Characteristic property at moisture content

P_{12} = same Characteristic property at 12% moisture content

P_g = same Characteristic property for Green wood

M_p = Intersection moisture content = 24%

Characteristic Property		% Reduction in characteristic strength at % MC					
		14	16	18	20	22	24
MOE (Stiffness)	E	3.3	6.5	9.7	12.7	15.6	18.4
MOR (Bending)	F'_b	8.4	16.1	23.1	29.6	35.5	40.9
Compression perpendicular to grain	f'_p	9.9	18.9	27.0	34.2	40.8	46.7
Compression parallel to grain	f'_c	11.0	20.7	29.4	37.2	44.1	50.2
Shear	f'_s	6.6	12.8	18.6	24.0	29.0	33.7

Supplementary information - wall frame fabricators

Smart10 LVL will swell if it receives significant moisture ingress, and not all of that swell will be recovered once the LVL's moisture content has stabilised to the equilibrium moisture content typically found in an enclosed house frame in Australia.

For multiple studs, the swelling of individual studs, and the water trapped between touching elements may compound to cause lateral displacement in frames and around openings.

The effect of swell can be reduced by:

1. Keeping the completed frames covered before delivery to site
2. Under sizing the noggings by 1-2 mm to allow for swelling. Exact length would vary based upon climate, season and

accuracy of cut

3. Nogging installation:
 - i. Leave end noggings out of wall frames to require the builders to add at the time of lining to reduce the effect of bowing on frame squareness

Alternatively

 - ii. Install a sliding end nogging at either the top or bottom of the frame that would be fixed onsite by the builder
4. Use the strength of Smart10 LVL to:
 - i. Increase stud spacing where applicable
 - ii. minimise the amount of multiple studs under concentrated loads
5. If the design calls for trenched top and bottom plates, the trenches should be overcut by 4 mm to accommodate the swell of the stud
6. Consider a solid timber bottom plate to minimise plate swelling.

Supplementary Information - Frame installers

1. Smart10 LVL frames should be enclosed as quickly as reasonable practical, or installed during extended periods of dry weather, to prevent swelling of the LVL sufficient to generate lateral displacement in frames and around openings
2. Maintain good airflow around framing elements and do not allow water to pool on or around element
3. Ensure that floors can drain by creating drainage holes in the floor substrate
4. Remove bottom plates in door openings as soon as possible to prevent longitudinal swelling in the bottom plate of the frames.
5. Install plasterboard lining 10 mm off the floor as per manufacturers' recommendations to allow for swell that may have occurred in the bottom plate.

Remedial measures for an excessively swelled frame

In the event that framing does get very wet, and construction is to continue immediately, the following remedial steps are recommended:

1. Enclose the frame as soon as possible
2. Knock out noggings in the wall frames to keep the frame end studs straight. Replace noggings before lining once the framing moisture content is below 20%.
3. Do not line the frames until the moisture content is below 20%
4. If planing is deemed necessary, planing of the top and bottom veneers is allowable to return the thickness of the LVL back to original
5. It is NOT recommended to plane back the depth of the LVL as it will shrink back to an undersized member once equalised to internal moisture content conditions.

Notching and holes in Smart10 LVL studs

The following diagram and tables are reproduced from AS 1684.2: 2021, and focused where necessary to only deal with studs.

The paragraph (b) below was introduced into the 2021 edition of AS 1684 to allow for larger holes/notches in non loadbearing

walls, and given the higher characteristic strength values of Smart10 LVL over solid sawn timber studs provides a conservative solution.

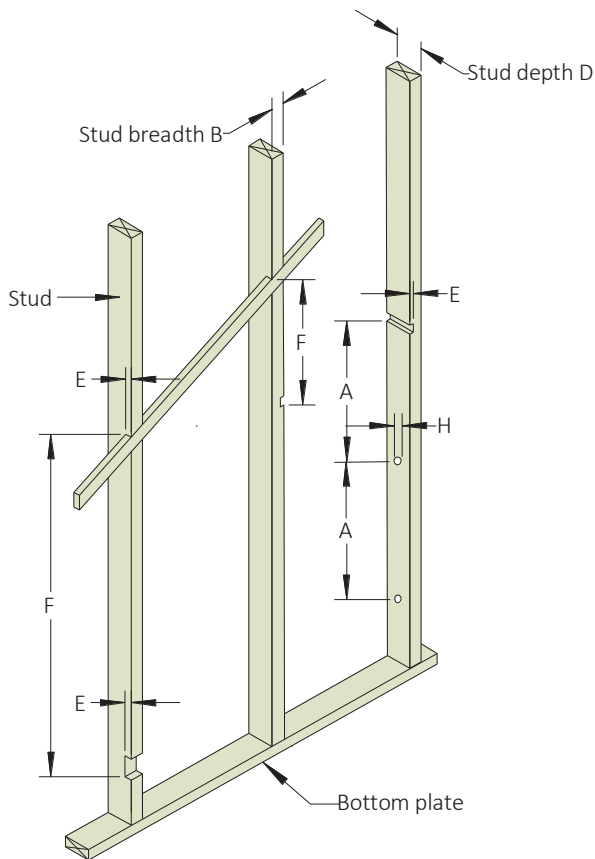

Symbol	Description	Limits	
		Notched	Not notched
A	Distance between holes and/or notches in stud breadth	Min. 3D	Min. 3D
H	Hole diameter (studs and plates)	Max. 25 mm (wide face only)	Max. 25 mm (wide face only)
C	Notch into stud breadth	Max. 10 mm	Max. 10 mm
E	Notch into stud depth	Max. 20 mm (for diagonal cut in bracing only) (see Notes 1 and 2)	Not permitted (see Note 1)
F	Distance between notches in stud depth	Min. 12B	N/A

NOTES

1. A horizontal line of notches up to 25 mm may be provided for the installation of baths
2. Except as permitted for diagonal cut in bracing, notches up to 20 mm may occur in every fifth individual stud.
3. For additional jamb stud requirements, see Figures 6.5, 6.9(A) and 6.9(B) of AS 1684.2:2021
4. Top and bottom plates in internal non-loadbearing and non-bracing walls may be discontinuous up to 60 mm (cut or drilled) to permit installation of services provided that, at the discontinuity, the plates are trimmed or otherwise reinforced either side of the discontinuity to maintain the lateral and longitudinal integrity of the wall.

(a) General (external walls, loadbearing walls and braced sections of internal non-loadbearing walls)

The maximum size and spacing of cuts, holes, notches and similar section reductions in studs shall be in accordance with the above diagram.

- i) Holes in studs and plates shall be located within the middle half of the depth and breadth of the member, respectively.
- ii) A longitudinal groove up to 18 mm wide × 10 mm deep may be machined into the middle third depth of a stud to accept full-length anchor rods. Where the groove exceeds this dimension, the remaining net breadth and depth of the stud shall be not less than the minimum size required.
- iii) Studs may be designed as notched or not-notched. For common studs, the maximum notch depth for single or upper storey or lower storey construction shall be 20 mm.
- iv) Jamb studs in external walls and other loadbearing walls shall not be notched within the middle half of their height or within the height of the opening. A notch up to a maximum of 20 mm in depth is permissible outside this region at the top and/or the bottom of the stud.

(b) Internal non-loadbearing walls (excluding sections of wall that have diagonal or structural sheet bracing installed)

The general requirements for internal non-loadbearing walls (excluding sections of wall that have diagonal or structural sheet bracing installed) shall be as specified in Item (a) above. The following additional allowances are permitted:

- i) Holes in plates and noggings of diameter up to 52 mm may be located on the centre-line of the wide face provided they are spaced a minimum of 1 800 mm apart and are not located adjacent to significant timber defects.
- ii) A single hole in a stud of diameter up to 52 mm may be located on the centre-line of the wide face provided they are not located adjacent to significant timber defects and can only occur not closer than in every fourth stud.
- iii) A single notch in a stud up to 50 % of the stud depth may be used. The notch can only occur not closer than in every fourth stud.

Common Stud—Single/upper storey walls—Un-notched

AS 4055 Classification N1-N4

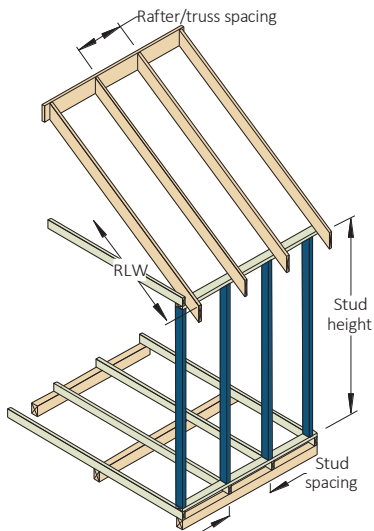

EXAMPLE:

Sheet roof
 Stud spacing = 450 mm
 Rafter truss spacing = 600 mm
 Stud height = 2700 mm
 Roof load width = 6500 mm
 Enter Stud spacing 450 table, sheet roof column, 600 mm in rafter/truss spacing column, read down to a span roof load width of 6500 mm in a 2700 mm stud height.

ADOPT:

Smart10 LVL - 70 x 45

Rafter/truss spacing (mm)		450	600	900	1200	450	600	900	1200
Size DxB (mm)	Stud height (mm)	Maximum recommended roof load width (mm)							
		Sheet Roof				Tile Roof			
Stud spacing 450 mm									
70x35	2400	7500	7500	6200	4700	7500	6600	4400	3300
	2700	6900	5200	3500	2600	5000	3800	2500	1900
	3000	3500	2500	1500	NS	2500	1500	NS	NS
70x45	2400	7500	7500	7500	7100	7500	7500	6800	5000
	2700	7500	7500	5900	4400	7500	6300	4100	3100
	3000	6500	4500	2500	2500	4500	3500	1500	1500
2/70x35	2400	7500	7500	7500	7500	7500	7500	7500	7500
	2700	7500	7500	7500	7500	7500	7500	7500	6500
	3000	7500	7500	7500	5500	7500	7500	5500	3500
2/70x45	2700	7500	7500	7500	7500	7500	7500	7500	7500
	3000	7500	7500	7500	7500	7500	7500	7500	5500
90x35	2400	7500	7500	7500	7500	7500	7500	7500	7500
	2700	7500	7500	7500	7500	7500	7500	7500	6100
	3000	7500	7500	6500	4500	7500	7500	4500	3500
90x45	2700	7500	7500	7500	7500	7500	7500	7500	7500
	3000	7500	7500	7500	7500	7500	7500	7500	5500
2/90x35	3000	7500	7500	7500	7500	7500	7500	7500	7500
2/90x45	3000	7500	7500	7500	7500	7500	7500	7500	7500
Stud spacing 600 mm									
70x35	2400	6400	6400	4200	3200	4500	4500	3000	2300
	2700	2600	2600	1800	NS	1900	1900	NS	NS
70x45	2400	7500	7500	7500	5700	7500	7500	5300	4000
	2700	6100	6100	4100	3100	4400	4400	3000	2200
	3000	2500	2500	1500	NS	1500	1500	NS	NS
2/70x35	2400	7500	7500	7500	7500	7500	7500	7500	7500
	2700	7500	7500	7500	7500	7500	7500	7500	5600
	3000	7500	7500	6500	4500	6500	6500	4500	3500
2/70x45	2700	7500	7500	7500	7500	7500	7500	7500	7500
	3000	7500	7500	7500	7500	7500	7500	6500	4500
90x35	2400	7500	7500	7500	7500	7500	7500	7500	7500
	2700	7500	7500	7500	6900	7500	7500	6500	4900
	3000	7500	7500	4500	3500	5500	5500	3500	2500
90x45	2700	7500	7500	7500	7500	7500	7500	7500	7500
	3000	7500	7500	7500	6500	7500	7500	5500	4500
2/90x35	3000	7500	7500	7500	7500	7500	7500	7500	7500
2/90x45	3000	7500	7500	7500	7500	7500	7500	7500	7500

NOTES :

1. D = member depth, B = member breadth, NS = not suitable.
2. The above table was based on a maximum wall mass of 37 kg/m²
3. Multiple studs to be laminated as per AS 1684
4. Stud not notched
5. Maximum tension load in stud not to exceed 8.5 kN. Where studs are nailed laminated the tension load in each stud shall not exceed 8.5 kN.
6. **Not all sizes of SmartLVL in this table are stocked in each state. Please check with your supplier before ordering**

Common Stud—Single/upper storey walls - Un-notched

AS 4055 Classification C1-C3

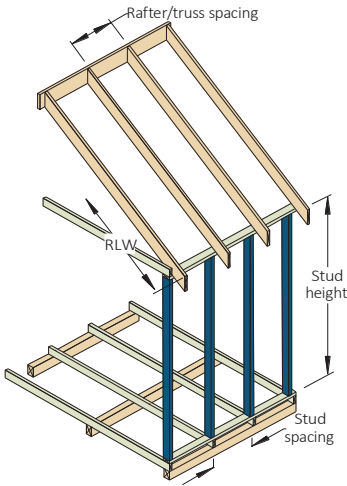

EXAMPLE:

Sheet roof
 Stud spacing = 450 mm
 Rafter truss spacing = 600 mm
 Stud height = 2700 mm
 Roof load width = 6300 mm
 Enter Stud spacing 450 table, sheet roof column, 600 mm in rafter/truss spacing column, read down to a span roof load width of 6300 mm in a 2700 mm stud height.

ADOPT:

Smart10 LVL - 2/70 x 35

Rafter/truss spacing (mm)		450	600	900	1200	450	600	900	1200
Size DxB (mm)	Stud height (mm)	Maximum recommended roof load width (mm)							
		Sheet Roof				Tile Roof			
Stud spacing 450 mm									
70x45	2400	4800	3600	2400	1800	3900	3000	2000	1500
2/70x35	2400	7500	7500	7300	5400	7500	7500	6000	4500
	2700	7500	6400	4300	3200	7000	5300	3500	2600
	3000	4500	2500	1500	1500	3500	2500	1500	NS
2/70x45	2400	7500	7500	7500	7500	7500	7500	7500	6700
	2700	7500	7500	6800	5200	7500	7500	5600	4200
	3000	7500	5500	3500	2500	6500	4500	2500	2500
90x35	2400	7500	7500	6000	4500	7500	7500	5000	3700
	2700	6000	4500	3000	2300	5000	3700	2500	1900
	3000	1500	1500	NS	NS	1500	NS	NS	NS
90x45	2400	7500	7500	7500	7400	7500	7500	7500	6000
	2700	7500	7500	5700	4300	7500	7100	4700	3600
	3000	5500	4500	2500	1500	4500	3500	2500	1500
2/90x35	2700	7500	7500	7500	7500	7500	7500	7500	7500
	3000	7500	7500	7500	5500	7500	7500	6500	4500
2/90x45	3000	7500	7500	7500	7500	7500	7500	7500	7500

Stud spacing 600 mm

2/70x35	2400	7500	7500	5400	4000	6800	6800	4500	3400
	2700	3800	3800	2600	1900	3200	3200	2100	1600
2/70x45	2400	7500	7500	7500	6700	7500	7500	7400	5500
	2700	7500	7500	5100	3900	6300	6300	4200	3200
	3000	3500	3500	2500	1500	2500	2500	1500	1500
90x35	2400	5000	5000	3400	2500	4100	4100	2800	2100
90x45	2400	7500	7500	7100	5400	7500	7500	5900	4400
	2700	4900	4900	3300	2500	4100	4100	2800	2100
2/90x35	2400	7500	7500	7500	7500	7500	7500	7500	7500
	2700	7500	7500	7500	7500	7500	7500	7500	6700
	3000	7500	7500	6500	4500	7500	7500	4500	3500
2/90x45	2700	7500	7500	7500	7500	7500	7500	7500	7500
	3000	7500	7500	7500	7500	7500	7500	7500	5500

NOTES :

1. D = member depth, B = member breadth, NS = not suitable.
2. The above table was based on a maximum wall mass of 37 kg/m²
3. Multiple studs to be laminated as per AS 1684
4. Stud not notched
5. Maximum tension load in stud not to exceed 8.5 kN. Where studs are nailed laminated the tension load in each stud shall not exceed 8.5 kN.
6. **Not all sizes of SmartLVL in this table are stocked in each state. Please check with your supplier before ordering**

Common Stud—Single/upper storey walls - 20 mm notched

AS 4055 Classification N1- N4

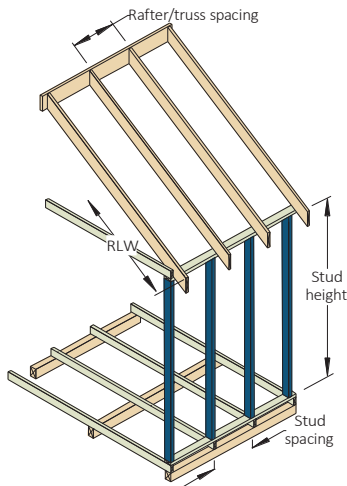

EXAMPLE:

Sheet roof
 Stud spacing = 450 mm
 Rafter truss spacing = 600 mm
 Stud height = 2700 mm
 Roof load width = 6300 mm
 Enter Stud spacing 450 table, sheet roof column, 600 mm in rafter/truss spacing column, read down to a span roof load width of 6300 mm in a 2700 mm stud height.

ADOPT:

Smart10 LVL - 70 x 35

Rafter/truss spacing (mm)		450	600	900	1200	450	600	900	1200
Size DxB (mm)	Stud height (mm)	Maximum recommended roof load width (mm)							
		Sheet Roof				Tile Roof			
Stud spacing 450 mm									
70x35	2400	7500	7500	5000	3700	7200	5500	3600	2600
	2700	5100	3700	2400	2000	3500	2700	1800	NS
70x45	2400	7500	7500	7500	5700	7500	7500	5500	4000
	2700	7500	6400	4200	3200	6200	4500	3100	2400
	3000	3500	2500	1500	1500	2500	1500	1500	NS
2/70x35	2400	7500	7500	7500	7500	7500	7500	7500	7500
	2700	7500	7500	7500	6700	7500	7500	6400	4800
	3000	7500	7500	5500	3500	7500	5500	3500	2500
2/70x45	2400	7500	7500	7500	7500	7500	7500	7500	7500
	2700	7500	7500	7500	7500	7500	7500	7500	6700
	3000	7500	7500	7500	5500	7500	7500	5500	3500
90x35	2400	7500	7500	7500	7500	7500	7500	7500	7500
	2700	7500	7500	7500	7200	7500	7500	6600	4900
	3000	7500	7500	5500	3500	7500	5500	3500	2500
90x45	2400	7500	7500	7500	7500	7500	7500	7500	7500
	2700	7500	7500	7500	7500	7500	7500	7500	7200
	3000	7500	7500	7500	5500	7500	7500	5500	4500
2/90x35	3000	7500	7500	7500	7500	7500	7500	7500	7500
2/90x45	3000	7500	7500	7500	7500	7500	7500	7500	7500
Stud spacing 600 mm									
70x35	2400	5600	5600	3700	2700	3800	3800	2600	1900
70x45	2400	7500	7500	6200	4600	6700	6700	4400	3300
	2700	4400	4400	3000	2200	3100	3100	2100	1500
2/70x35	2400	7500	7500	7500	7500	7500	7500	7500	6800
	2700	7500	7500	7500	5800	7500	7500	5500	4100
	3000	6500	6500	4500	2500	4500	4500	2500	1500
2/70x45	2400	7500	7500	7500	7500	7500	7500	7500	7500
	2700	7500	7500	7500	7500	7500	7500	7500	6000
	3000	7500	7500	6500	4500	7500	7500	4500	3500
90x35	2400	7500	7500	7500	7500	7500	7500	7500	7000
	2700	7500	7500	7500	5700	7500	7500	5200	3900
	3000	4500	4500	3500	2500	3500	3500	2500	1500
90x45	2400	7500	7500	7500	7500	7500	7500	7500	7500
	2700	7500	7500	7500	7500	7500	7500	7500	6100
	3000	7500	7500	6500	4500	6500	6500	4500	3500
2/90x35	3000	7500	7500	7500	7500	7500	7500	7500	7500
2/90x45	3000	7500	7500	7500	7500	7500	7500	7500	7500

Common Stud—Single/upper storey walls - 20 mm notched

AS 4055 Classification C1 – C3

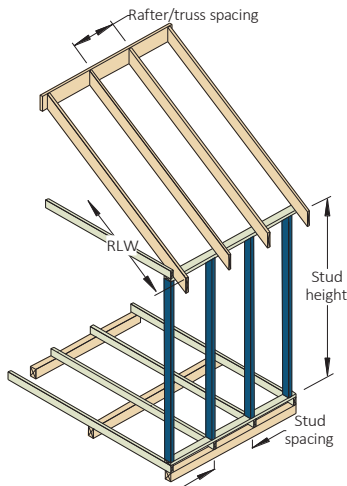

EXAMPLE:

Sheet roof

Stud spacing = 450 mm

Rafter truss spacing = 600 mm

Stud height = 2700 mm

Roof load width = 6500 mm

Enter Stud spacing 450 table, sheet roof column, 600 mm in rafter/truss spacing column, read down to a span roof load width of 6500 mm in a 2700 mm stud height.

ADOPT:

Smart10 LVL - 2/70 x 45

Rafter/truss spacing (mm)		450	600	900	1200	450	600	900	1200
Size DxB (mm)	Stud height (mm)	Maximum recommended roof load width (mm)							
		Sheet Roof				Tile Roof			
Stud spacing 450 mm									
70x45	2400	4400	3300	2100	1600	3700	2700	1800	NS
2/70x35	2400	7500	7500	5800	4500	7500	7400	4800	3600
2/70x45	2700	6300	4700	3100	2400	5200	3800	2600	2000
	3000	2500	1500	NS	NS	1500	1500	NS	NS
	2400	7500	7500	7500	6600	7500	7500	7100	5400
	2700	7500	7500	5000	3700	7500	6500	4200	3300
90x35	3000	5500	3500	2500	1500	4500	2500	1500	1500
	2400	7500	7500	5600	4100	7500	6900	4700	3500
90x45	2700	5000	3500	2300	1700	3900	2900	1900	NS
	2400	7500	7500	7500	6600	7500	7500	7300	5500
2/90x35	2700	7500	7200	4500	3400	7500	5700	3800	2900
	3000	3500	2500	1500	NS	2500	1500	1500	NS
	2400	7500	7500	7500	7500	7500	7500	7500	7500
	2700	7500	7500	7500	7500	7500	7500	7500	6500
2/90x45	3000	7500	7500	6500	4500	7500	7500	4500	3500
	2700	7500	7500	7500	7500	7500	7500	7500	7500
	3000	7500	7500	7500	6500	7500	7500	7500	5500

Stud spacing 600 mm									
2/70x35	2400	7000	7000	4700	3500	5600	5600	3700	2800
	2700	2900	2900	1800	NS	2200	2200	NS	NS
2/70x45	2400	7500	7500	7400	5600	7500	7500	6000	4500
	2700	5800	5800	3700	2900	4800	4800	3000	2300
	3000	1500	1500	NS	NS	1500	1500	NS	NS
	2400	5200	5200	3500	2600	4400	4300	2800	2100
90x35	2400	7500	7500	6800	5000	7500	7500	5500	4000
	2700	4200	4200	2500	1900	3200	3200	2000	1500
2/90x35	2400	7500	7500	7500	7500	7500	7500	7500	7500
	2700	7500	7500	7500	6800	7500	7500	7300	5400
	3000	6500	6500	4500	3500	5500	5500	3500	2500
	2700	7500	7500	7500	7500	7500	7500	7500	7500
2/90x45	3000	7500	7500	7500	5500	7500	7500	6500	4500

NOTES :

1. D = member depth, B = member breadth, NS = not suitable.
2. The above table was based on a maximum wall mass of 37 kg/m²
3. Multiple studs to be laminated as per AS 1684
4. Maximum tension load in stud not to exceed 8.5 kN. Where studs are nailed laminated the tension load in each stud shall not exceed 8.5 kN.
5. **Not all sizes of SmartLVL in this table are stocked in each state. Please check with your supplier before ordering**

Jamb Stud—Single of upper load bearing walls

AS 4055 Classification N1-N4

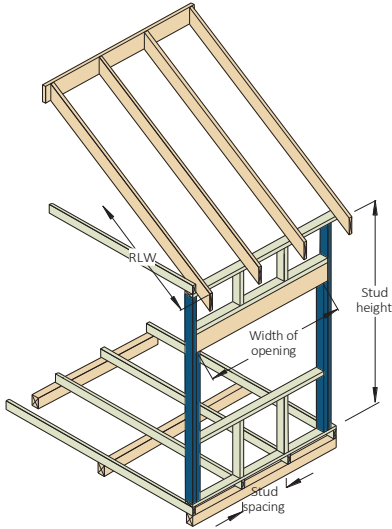

EXAMPLE:

Sheet roof
 Width of opening = 1800 mm
 Jamb stud height = 2700 mm
 Roof load width = 4100 mm

Enter table at 4500 mm roof load width, sheet roof column, read down to a width of opening of 1800 mm in a 2700 mm stud height row with a roof mass of 40 kg/m².

ADOPT:

Smart10 LVL - 2/90 x 35

Roof load width (mm)		1500	3000	4500	6000	7500	1500	3000	4500	6000	7500
Size DxB (mm)	Stud height (mm)	Sheet roof					Tile roof				
		Width of opening (mm)					Width of opening (mm)				
90x35	2400	2200	2000	1600	1400	1200	2200	1800	1500	1200	900
	2700	1400	1400	1200	1000	NS	1400	1300	1000	NS	NS
2/70x35	2400	2100	2100	1800	1500	1400	2100	2100	1600	1400	1100
	2700	1200	1200	1100	1000	1000	1200	1200	1100	900	NS
2/90x35	2400	4500	4500	4000	3300	2700	4500	4500	3400	2700	2300
	2700	3600	3600	3200	2500	2200	3600	3300	2700	2200	1800
	3000	1800	1800	1800	1800	900	1800	1800	1800	900	900
3/70x35	2400	3600	3600	3200	2500	2200	3600	3600	2700	2000	1700
	2700	2200	2200	2200	2000	1600	2200	2200	2000	1400	1300
	3000	900	900	900	900	900	900	900	900	900	900
3/90x35	2400	4500	4500	4500	4500	4500	4500	4500	4500	4500	3600
	2700	4500	4500	4500	4200	3600	4500	4500	4200	3400	2900
	3000	3600	3600	3600	2700	2700	3600	3600	2700	2700	1800
70x45	2400	900	900	900	NS	NS	900	900	NS	NS	NS
90x45	2400	3200	2700	2200	1800	1700	3200	2500	1800	1500	1400
	2700	1800	1800	1600	1400	1300	1800	1800	1400	1200	900
	3000	900	900	900	900	900	900	900	900	NS	NS
2/70x45	2400	2700	2700	2500	2000	1800	2700	2700	2200	1700	1400
	2700	1800	1800	1800	1400	1400	1800	1800	1600	1300	1000
	3000	900	900	900	900	900	900	900	900	900	NS
2/90x45	2400	4500	4500	4500	4500	3600	4500	4500	4500	3600	3000
	2700	4500	4500	4000	3400	2900	4500	4500	3600	2900	2300
	3000	2700	2700	2700	2700	1800	2700	2700	2700	1800	1800
3/70x45	2400	4500	4500	4000	3300	2700	4500	4500	3600	2700	2300
	2700	3200	3200	3000	2500	2200	3200	3200	2700	2200	1800
	3000	1800	1800	1800	1800	900	1800	1800	1800	900	900
3/90x45	2700	4500	4500	4500	4500	4500	4500	4500	4500	4500	3900
	3000	4500	4500	4500	3600	3600	4500	4500	4500	3600	2700

NOTES:

1. D = member depth, B = member breadth, NS = not suitable
2. The above table was based on a maximum sheet roof mass of 40 kg/m², tile roof mass of 90 kg/m²
3. Multiple studs to be laminated as per AS 1684
4. Support crushing check is not considered, minimum of 2 studs under concentrated loads is highly recommended to avoid crushing of the bottom plates
5. Maximum tension load in stud not to exceed 8.5 kN. Where studs are nailed laminated the tension load in each stud shall not exceed 8.5 kN
6. **Not all sizes of SmartLVL in this table are stocked in each state. Please check with your supplier before ordering**

Jamb Stud—Single of upper load bearing walls AS 4055 Classification C1-C3

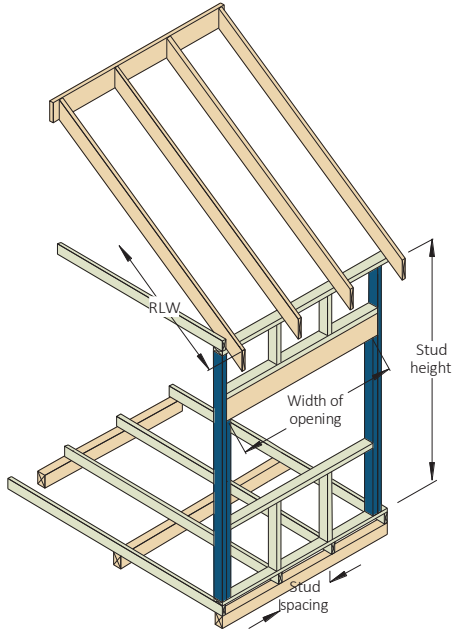

EXAMPLE:

Sheet roof

Width of opening = 1800 mm

Jamb stud height = 2700 mm

Roof load width = 4100 mm

Enter table at 4500 mm roof load width, sheet roof column, read down to a width of opening of 1800 mm in a 2700 mm stud height row with a roof mass of 40 kg/m².

ADOPT:

Smart10 LVL - 2/90x45

Roof load width (mm)		1500	3000	4500	6000	7500	1500	3000	4500	6000	7500
Size DxB (mm)	Stud height (mm)	Sheet roof					Tile roof				
		Width of opening (mm)					Width of opening (mm)				
2/90x35	2400	2200	2100	1800	1500	1400	2200	2100	1600	1400	1200
	2700	1400	1400	1300	1200	1000	1400	1400	1200	1000	NS
3/70x35	2400	1400	1400	1400	1200	1000	1400	1400	1300	1100	NS
3/90x35	2400	3600	3600	3000	2500	2200	3600	3600	2700	2300	2000
	2700	2400	2400	2200	2000	1600	2400	2400	2200	1800	1400
	3000	900	900	900	900	900	900	900	900	900	900
90x45	2400	1200	1100	900	NS	NS	1200	1100	NS	NS	NS
2/70x45	2400	900	900	900	900	NS	900	900	900	NS	NS
2/90x45	2400	3200	3000	2500	2000	1800	3200	3000	2200	1800	1700
	2700	2100	2100	1800	1400	1400	2100	2100	1600	1400	1300
	3000	900	900	900	900	900	900	900	900	900	900
3/70x45	2400	1800	1800	1800	1500	1400	1800	1800	1800	1400	1200
	2700	1100	1100	1100	1000	1000	1100	1100	1100	1000	NS
3/90x45	2400	4500	4500	4000	3300	2700	4500	4500	3600	3000	2500
	2700	3600	3600	3200	2500	2200	3600	3600	2900	2300	2000
	3000	1800	1800	1800	1800	900	1800	1800	1800	1800	900

NOTES:

1. D = member depth, B = member breadth, NS = not suitable
2. The above table was based on a maximum sheet roof mass of 40 kg/m², tile roof mass of 90 kg/m²
3. Multiple studs to be laminated as per AS 1684
4. Support crushing check is not considered, minimum of 2 studs under concentrated loads is highly recommended to avoid crushing of the bottom plates
5. Maximum tension load in stud not to exceed 8.5 kN. Where studs are nailed laminated the tension load in each stud shall not exceed 8.5 kN
6. **Not all sizes of SmartLVL in this table are stocked in each state. Please check with your supplier before ordering**

Wall studs - lower storey load bearing walls - Non notched

AS 4055 classification N1 - N4

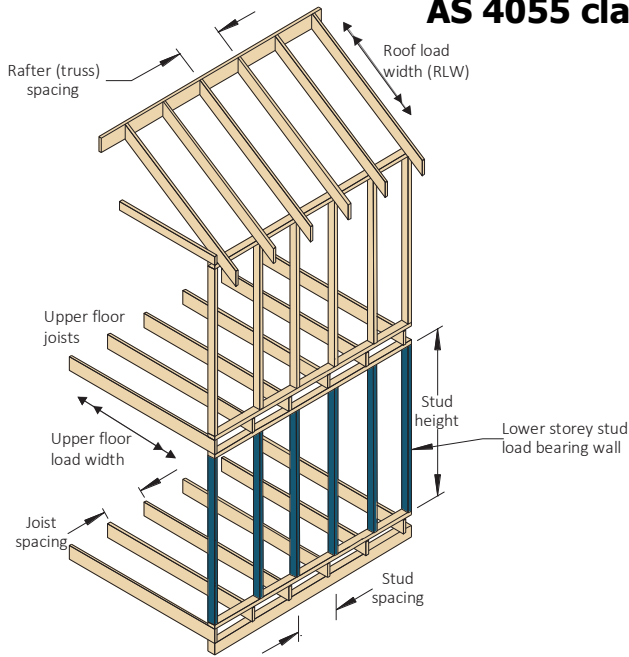

EXAMPLE:

- Un - notched stud
- Stud spacing = 450 mm
- Floor joist spacing = 600 mm
- Stud height = 3000 mm
- Floor load width = 4100 mm
- Roof load width = 7500 mm

Enter table at 450 mm stud spacing column, 600 mm joist spacing column, 4800 floor load width column, read down to a roof load width of 7500 mm in a 3000 mm stud height row.

ADOPT:

Smart10 LVL - 90x35

Sheet roof 40 kg/m ²													
Stud spacing (mm)		450						600					
Floor joist spacing (mm)		450			600			450			600		
Upper floor load width (mm)		1800	3600	4800	1800	3600	4800	1800	3600	4800	1800	3600	4800
Size DxB (mm)	Stud height (mm)	Roof load width (RLW) (mm)											
70x35	2400	7500	7500	7500	7500	7500	7500	7500	7500	7500	7500	7500	7500
	2700	7500	7500	7500	7500	7500	7100	5800	7000	5300	3900	7000	5300
	3000	1500	1500	2500	1500	1500	NS	NS	NS	NS	NS	NS	NS
90x35	3000	7500	7500	7500	7500	7500	7500	7500	7500	7500	7500	7500	7500
2/70x35	3000	7500	7500	7500	7500	7500	7500	7500	7500	7500	7500	7500	7500
2/90x35	3000	7500	7500	7500	7500	7500	7500	7500	7500	7500	7500	7500	7500
70x45	2700	7500	7500	7500	7500	7500	7500	7500	7500	7500	7500	7500	7500
	3000	7500	7500	7500	7500	6000	4800	NS	NS	NS	NS	NS	NS
90x45	3000	7500	7500	7500	7500	7500	7500	7500	7500	7500	7500	7500	7500
2/70x45	3000	7500	7500	7500	7500	7500	7500	7500	7500	7500	7500	7500	7500
2/90x45	3000	7500	7500	7500	7500	7500	7500	7500	7500	7500	7500	7500	7500
Tile Roof 90 kg/m ²													
70x35	2400	7500	7500	7500	7500	7500	6500	7500	7500	6500	7500	7500	6500
	2700	7500	6500	5500	5500	4500	2500	4500	3500	2500	4500	3500	2500
	3000	4500	2500	2500	2500	1500	NS	NS	NS	NS	NS	NS	NS
90x35	3000	7500	7500	7500	7500	7500	7500	7500	7500	7500	7500	7500	7500
2/70x35	2700	7500	7500	7500	7500	7500	7500	7500	7500	7500	7500	7500	7500
	3000	7500	7500	7500	7500	7500	7500	7500	7500	6500	7500	7500	6500
2/90x35	3000	7500	7500	7500	7500	7500	7500	7500	7500	7500	7500	7500	7500
70x45	2400	7500	7500	7500	7500	7500	7500	7500	7500	7500	7500	7500	7500
	2700	7500	7500	7500	7500	6500	5500	7500	6500	5500	7500	6500	5500
	3000	7500	5500	4500	5500	3500	2500	NS	NS	NS	NS	NS	NS
90x45	3000	7500	7500	7500	7500	7500	7500	7500	7500	7500	7500	7500	7500
2/70x45	3000	7500	7500	7500	7500	7500	7500	7500	7500	7500	7500	7500	7500
2/90x45	3000	7500	7500	7500	7500	7500	7500	7500	7500	7500	7500	7500	7500

NOTES :

1. D = member depth, B = member breadth, NS = not suitable.
2. Total upper floor mass of 40 kg/m², total wall mass of 37 kg/m², floor live load of 1.5 kPa
3. Stud not notched. Maximum tension load in stud not to exceed 8.5 kN.
4. Where studs are nailed laminated the tension load in each stud shall not exceed 8.5 kN.
5. **Not all sizes of SmartLVL in this table are stocked in each state. Please check with your supplier before ordering**

Wall studs - lower storey load bearing walls - Non notched

AS 4055 classification C1 - C3

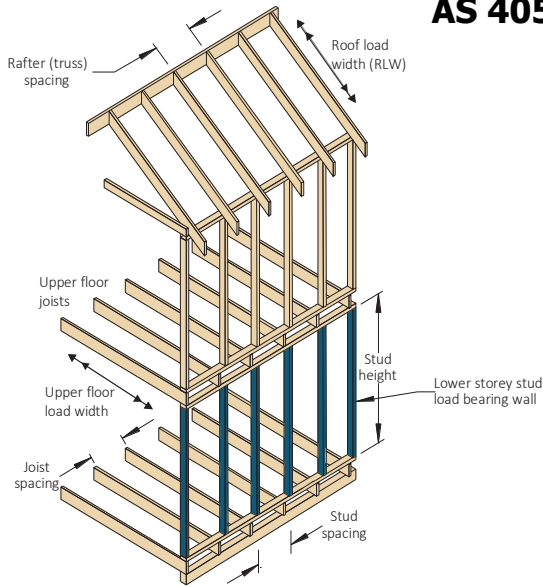

EXAMPLE:

- Un - notched stud
- Stud spacing = 450 mm
- Floor joist spacing = 600 mm
- Stud height = 3000 mm
- Floor load width = 4100 mm
- Roof load width =

Enter table at 450 mm stud spacing column, 600 mm joist spacing column, 4800 mm floor load width, read down to a roof load width of 7500 mm in a 3000 mm stud height row.

ADOPT:

Smart10 LVL - 90 x 35

Sheet roof 40 kg/m ²													
Stud spacing (mm)		450						600					
Floor joist spacing (mm)		450			600			450			600		
Upper floor load width (mm)		1800	3600	4800	1800	3600	4800	1800	3600	4800	1800	3600	4800
Size Dx B (mm)	Stud height (mm)	Roof load width (RLW) (mm)											
70x35	2400	7500	7500	7500	7500	7500	7500	7500	7500	7500	7500	7500	7500
	2700	7500	7500	7500	7500	7100	5800	7000	5300	3900	7000	5300	3900
	3000	1500	1500	2500	1500	1500	NS	NS	NS	NS	NS	NS	NS
90x35	3000	7500	7500	7500	7500	7500	7500	7500	7500	7500	7500	7500	7500
2/70x35	3000	7500	7500	7500	7500	7500	7500	7500	7500	7500	7500	7500	7500
2/90x35	3000	7500	7500	7500	7500	7500	7500	7500	7500	7500	7500	7500	7500
70x45	2700	7500	7500	7500	7500	7500	7500	7500	7500	7500	7500	7500	7500
	3000	7500	7500	7500	7500	6000	4800	NS	NS	NS	NS	NS	NS
90x45	3000	7500	7500	7500	7500	7500	7500	7500	7500	7500	7500	7500	7500
2/70x45	3000	7500	7500	7500	7500	7500	7500	7500	7500	7500	7500	7500	7500
2/90x45	3000	7500	7500	7500	7500	7500	7500	7500	7500	7500	7500	7500	7500
Tile Roof 90 kg/m ²													
70x35	2400	7500	7500	7500	7500	7500	6500	7500	7500	6500	7500	7500	6500
	2700	7500	6500	5500	5500	4500	2500	4500	3500	2500	4500	3500	2500
	3000	4500	2500	2500	2500	1500	NS	NS	NS	NS	NS	NS	NS
90x35	3000	7500	7500	7500	7500	7500	7500	7500	7500	7500	7500	7500	7500
2/70x35	2700	7500	7500	7500	7500	7500	7500	7500	7500	7500	7500	7500	7500
	3000	7500	7500	7500	7500	7500	7500	7500	7500	6500	7500	7500	6500
2/90x35	3000	7500	7500	7500	7500	7500	7500	7500	7500	7500	7500	7500	7500
70x45	2400	7500	7500	7500	7500	7500	7500	7500	7500	7500	7500	7500	7500
	2700	7500	7500	7500	7500	6500	5500	7500	6500	5500	7500	6500	5500
	3000	7500	5500	4500	5500	3500	2500	NS	NS	NS	NS	NS	NS
90x45	3000	7500	7500	7500	7500	7500	7500	7500	7500	7500	7500	7500	7500
2/70x45	3000	7500	7500	7500	7500	7500	7500	7500	7500	7500	7500	7500	7500
2/90x45	3000	7500	7500	7500	7500	7500	7500	7500	7500	7500	7500	7500	7500

NOTES :

1. D = member depth, B = member breadth, NS = not suitable.
2. Total upper floor mass of 40 kg/m², total wall mass of 37 kg/m², floor live load of 1.5 kPa
3. Stud not notched. Maximum tension load in stud not to exceed 8.5 kN.
4. Where studs are nailed laminated the tension load in each stud shall not exceed 8.5 kN.
5. **Not all sizes of SmartLVL in this table are stocked in each state. Please check with your supplier before ordering**

Studs lower storey of two(2) storey walls Supporting floor loads only

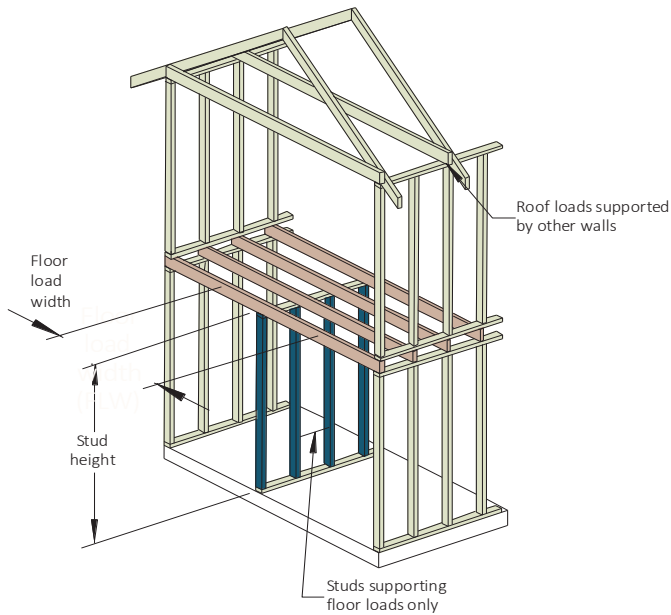

EXAMPLE:

Un - notched stud

Stud spacing = 450 mm

Floor joist spacing = 600 mm

Stud height = 2700 mm

Floor load width = 4100 mm

Enter table at 450 mm stud spacing column, 600 mm joist spacing column, read down to a floor load width of 4100 mm in a 2700 mm stud height row.

ADOPT:

Smart10 LVL - 90 x 35

Stud spacing (mm)		450		600	
Floor joist spacing (mm)		450	600	450	600
Size DxB (mm)	Stud height (mm)	Maximum recommended floor load width (mm)			
70x35	2400	8000	8000	8000	8000
90x35	3000	8000	8000	8000	8000
2/70x35	2700	8000	8000	8000	8000
	3000	8000	8000	NS	NS
2/90x35	3000	8000	8000	8000	8000
	2700	8000	8000	8000	8000
70x45	2400	8000	8000	8000	8000
	2700	8000	8000	NS	NS
90x45	3000	8000	8000	8000	8000
2/70x45	3000	8000	8000	8000	8000
2/90x45	3000	8000	8000	8000	8000

a. Un-notched

Stud spacing (mm)		450		600	
Floor joist spacing (mm)		450	600	450	600
Size DxB (mm)	Stud height (mm)	Maximum recommended floor load width (mm)			
70x35	2400	8000	6400	NS	NS
90x35	2700	8000	8000	8000	8000
	3000	8000	6000	NS	NS
2/70x35	2700	8000	8000	8000	8000
	3000	8000	6000	NS	NS
2/90x35	3000	8000	8000	8000	8000
70x45	2400	8000	8000	8000	8000
90x45	3000	8000	8000	8000	8000
2/70x45	3000	8000	8000	8000	8000
2/90x45	3000	8000	8000	8000	8000

b. 20 mm notch

NOTES :

1. D = member depth, B = member breadth, NS = not suitable
2. The above table was based on a maximum upper floor mass of 40 kg/m², total wall mass of 15 kg/m², floor live load of 1.5 kPa
3. Multiple studs to be nail laminated as per AS 1684
4. Wall stud notched to a maximum depth of 20 mm.
5. **Not all sizes of SmartLVL in this table are stocked in each state. Please check with your supplier before ordering**

Studs supporting concentrated roof loads

AS 4055 Wind classifications N1-N4 & C1-C3

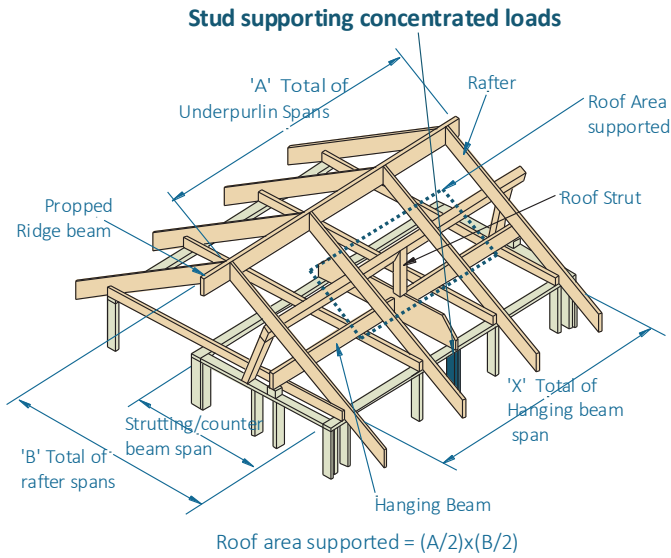

EXAMPLE:

Sheet roof

AS 4055 Classification N3

Jamb stud height = 2700 mm

Roof area = 12 m²

Enter table N1-N3 wind classification, 2700 stud height, sheet roof column, read down to a roof area of 12

ADOPT:

Smart10 LVL - 90 x 35

AS 4055 Classification N1-N3												
Stud height (mm)	2400	2700	3000	3600	4200	4800	2400	2700	3000	3600	4200	4800
Member size (mm)	Roof area supported (m ²)											
	Sheet Roof						Tile Roof					
70x35	13	9	7	4	3	NS	8	6	4	2	NS	NS
90x35	28	19	14	8	5	2	16	12	9	5	3	2
2/70x35	26	18	13	7	5	2	15	11	8	5	3	2
2/90x35	40	38	30	16	10	6	34	25	17	10	6	4
70x45	16	12	9	5	3	2	10	7	5	3	NS	NS
90x45	35	26	18	11	7	4	21	15	11	6	4	2
2/70x45	33	24	17	10	6	4	20	14	11	6	4	2
2/90x45	40	40	37	20	14	8	40	32	24	13	8	4
AS 4055 Classification C1-C3												
Stud height (mm)	2400	2700	3000	3600	4200	4800	2400	2700	3000	3600	4200	4800
Member size (mm)	Roof area supported (m ²)											
	Sheet Roof						Tile Roof					
70x35	7	5	4	2	NS	NS	6	4	3	NS	NS	NS
90x35	15	11	8	4	3	2	12	9	6	4	2	NS
2/70x35	14	10	7	4	3	NS	11	8	6	4	2	NS
2/90x35	31	22	15	9	6	4	25	17	13	7	5	2
70x45	9	6	5	3	NS	NS	7	5	4	2	NS	NS
90x45	19	14	10	6	4	2	15	11	8	5	3	2
2/70x45	18	13	10	5	3	2	14	11	8	4	3	2
2/90x45	38	29	20	12	7	4	32	23	16	9	6	4

NOTES:

1. D = member depth, B = member breadth, NS = not suitable
2. The above table was based on a maximum sheet roof mass of 40 kg/m², tile roof mass of 90 kg/m²
3. Multiple studs to be laminated as per AS 1684
4. Support crushing check is not considered, minimum of 2 studs under concentrated loads is highly recommended to avoid crushing of the bottom plates
5. Maximum tension load in stud not to exceed 8.5 kN. Where studs are nailed laminated the tension load in each stud shall not exceed 8.5 kN
6. **Not all sizes of SmartLVL in this table are stocked in each state. Please check with your supplier before ordering**

Single span lintels in single/upper storey walls

AS 4055 classification N1-N4 and C1-C3

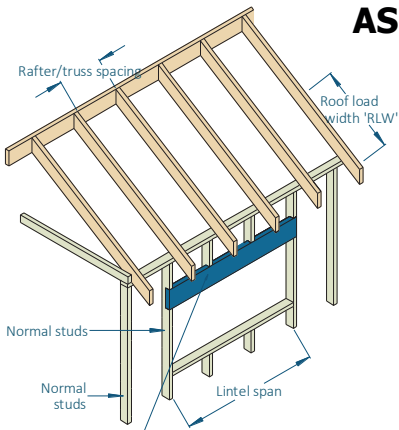

Single/Upper storey lintel

EXAMPLE:

wind speed = N3

sheet roof - 40 kg/m²

rafter/truss spacing = 600 mm

lintel span = 1300 mm

roof load width = 3900 mm

Enter span table at 4500 roof load width column, rafter/truss spacing 600 mm, and read down to a span equal to or greater than 1300 mm in the 40 kg/m² row

ADOPT:

Smart10 LVL - 120 x 35

Wind classification N1-N4											
Roof load width (mm)		1500		3000		4500		6000		7500	
Rafter/truss spacing (mm)		600	1200	600	1200	600	1200	600	1200	600	1200
Size Dx B (mm)	Roof Mass (kg/m ²)	Maximum recommended lintel span (mm)									
90x35	40	1500	1400	1200	NS	1000	NS	NS	NS	NS	NS
	90	1200	1000	NS	NS	NS	NS	NS	NS	NS	NS
120x35	40	2100	2100	1600	1500	1400	1100	1200	NS	1100	NS
	90	1600	1500	1300	1100	1100	NS	NS	NS	NS	NS
2/90x35	40	2000	2000	1500	1400	1300	1100	1200	1000	1000	NS
	90	1500	1400	1200	1000	1000	NS	NS	NS	NS	NS
2/120x35	40	2600	2700	2000	2000	1700	1700	1500	1500	1400	1300
	90	2000	2000	1600	1500	1400	1200	1200	1000	1100	NS
90x45	40	1700	1600	1300	1100	1100	NS	1000	NS	NS	NS
	90	1300	1100	1000	NS	NS	NS	NS	NS	NS	NS
120x45	40	2300	2300	1700	1700	1500	1400	1400	1000	1200	NS
	90	1700	1700	1400	1200	1200	1000	1000	NS	NS	NS
2/90x45	40	2100	2100	1600	1600	1400	1300	1300	1100	1100	1000
	90	1600	1600	1300	1100	1100	NS	1000	NS	NS	NS
2/120x45	40	2800	2800	2200	2200	1900	1900	1700	1600	1500	1500
	90	2200	2200	1700	1700	1500	1400	1400	1200	1200	1000
Wind classification C1-C3											
90x35	40	1300	NS	NS	NS	NS	NS	NS	NS	NS	NS
	90	1200	NS	NS	NS	NS	NS	NS	NS	NS	NS
120x35	40	1800	1500	1200	NS	NS	NS	NS	NS	NS	NS
	90	1600	1500	1300	NS	NS	NS	NS	NS	NS	NS
2/90x35	40	1900	1900	1400	NS	1100	NS	NS	NS	NS	NS
	90	1500	1400	1200	1000	1000	NS	NS	NS	NS	NS
2/120x35	40	2600	2700	1900	1700	1500	1100	1300	NS	1200	NS
	90	2000	2000	1600	1500	1400	1100	1200	NS	1100	NS
90x45	40	1500	1000	1000	NS	NS	NS	NS	NS	NS	NS
	90	1300	1100	1000	NS	NS	NS	NS	NS	NS	NS
120x45	40	2000	1900	1400	NS	1100	NS	NS	NS	NS	NS
	90	1700	1700	1400	1000	1100	NS	NS	NS	NS	NS
2/90x45	40	2100	2100	1600	1200	1300	NS	1100	NS	NS	NS
	90	1600	1600	1300	1100	1100	NS	1000	NS	NS	NS
2/120x45	40	2800	2800	2200	2100	1700	1400	1500	1100	1400	NS
	90	2200	2200	1700	1700	1500	1400	1400	1100	1200	NS

NOTES:

1. D = member depth, B = member breadth, NS = not suitable.
2. Minimum bearing length = 35 mm at end supports. Subscript values indicate the minimum additional bearing length where required to be greater than 35 mm.
3. Restraint value for slenderness calculations is 600 mm.
4. **Not all sizes of SmartLVL in this table are stocked in each state. Please check with your supplier before ordering**

Single span lintels in lower storey walls AS 4055 classification up to C3

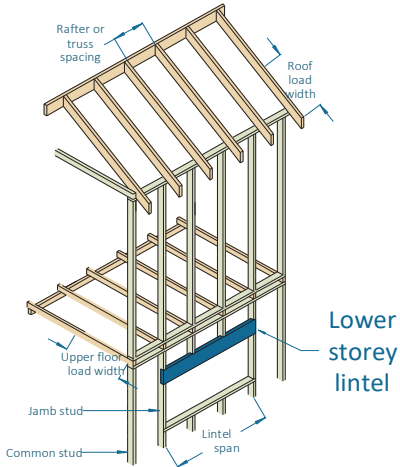

EXAMPLE:

wind speed = N3

sheet roof - 40 kg/m²

rafter/truss spacing = 600 mm

lintel span = 1100 mm

roof load width = 3900 mm

floor load width = 1200 mm

Enter span table at 4500 roof load width column, floor load width 1200 mm, and read down to a span equal to or greater than 1100 mm in the 40 kg/m² row

ADOPT:

Smart10 LVL -120 x 35

Roof load width (mm)		1500			3000			4500			6000		
Upper floor load width (mm)		1200	2400	3600	1200	2400	3600	1200	2400	3600	1200	2400	3600
Size DxB (mm)	Roof mass (kg/m ²)	Maximum recommended lintel span (mm)											
90x35	40	NS	NS	NS	NS	NS	NS	NS	NS	NS	NS	NS	NS
	90	NS	NS	NS	NS	NS	NS	NS	NS	NS	NS	NS	NS
120x35	40	1300	1100	1100	1200	1100	1000	1100	1100	1000	1100	1000	NS
	90	1200	1100	1000	1100	1000	NS	1000	NS	NS	NS	NS	NS
2/90x35	40	1200	1100	1000	1100	1000	NS	1100	1000	NS	1000	1000	NS
	90	1100	1000	NS	1000	NS	NS	NS	NS	NS	NS	NS	NS
2/120x35	40	1600	1500	1300	1500	1400	1300	1500	1300	1300	1400	1300	1200
	90	1500	1400	1300	1400	1300	1200	1300	1200	1100	1200	1100	1100
90x45	40	1000	NS	NS	1000	NS	NS	NS	NS	NS	NS	NS	NS
	90	1000	NS	NS	NS	NS	NS	NS	NS	NS	NS	NS	NS
120x45	40	1400	1300	1100	1300	1200	1100	1300	1200	1100	1200	1100	1000
	90	1300	1200	1100	1200	1100	1000	1100	1000	1000	1000	1000	NS
2/90x45	40	1300	1200	1100	1200	1100	1000	1200	1100	1000	1100	1000	1000
	90	1200	1100	1000	1100	1000	1000	1000	1000	NS	NS	NS	NS
2/120x45	40	1800	1600	1500	1700	1500	1400	1600	1500	1400	1500	1400	1300
	90	1600	1500	1400	1500	1400	1300	1400	1300	1200	1300	1200	1200

NOTES:

1. D = member depth, B = member breadth, NS = not suitable.
2. Minimum bearing length = 35 mm at end supports. Subscript values indicate the minimum additional bearing length where required to be greater than 35 mm.
3. Restraint value for slenderness calculations is 600 mm.
4. **Not all sizes of SmartLVL in this table are stocked in each state. Please check with your supplier before ordering.**

Single/continuous span roof rafter - with ceiling attached

AS 4055 classification N1-N4 & C1-C3

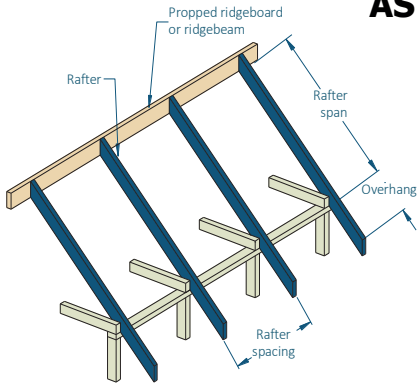

Maximum Birdsmouth = 30% of rafter depth

EXAMPLE:

wind speed = N3

sheet roof - 40 kg/m²

rafter/truss spacing = 600 mm

rafter span = 3000 mm (single span)

Enter span table at rafter spacing of 600 mm, and read down to a span equal to or greater than 3000 mm in the 40 kg/m² row

ADOPT:

Smart10 LVL - 120 x 45

Wind classification N1– N4																	
Rafter Spacing (mm)		450		600		900		1200		450		600		900		1200	
Size DxB (mm)	Roof & ceiling mass (kg/m ²)	Span	O/H	Span	O/H	Span	O/H	Span	O/H	Span	O/H	Span	O/H	Span	O/H	Span	O/H
Maximum recommended single span										Maximum recommended continuous span							
90x35	30	1800	200	1800	200	1800	200	1800	200	2200	200	2300	200	2300	200	2300	200
	40	1800	200	1800	200	1800	200	1700	200	2300	200	2300	200	2300	200	2300	200
	75	1800	200	1800	200	1500	200	1400	200	2300	200	2300	200	2100	200	1900	200
	90	1800	200	1700	200	1500	200	1300	200	2300	200	2300	200	2000	200	1800	200
120x35	30	2800	250	2800	250	2700	250	2500	200	3500	250	3500	250	3500	250	3300	200
	40	2800	250	2800	250	2500	250	2300	200	3500	250	3500	250	3500	250	3200	200
	75	2600	250	2400	200	2100	200	1900	200	3500	250	3200	200	2800	200	2600	200
	90	2400	250	2200	200	1900	200	1800	200	3300	250	3000	200	2700	200	2400	200
90x45	30	2100	200	2100	200	2000	200	2000	200	2600	200	2600	200	2600	200	2600	200
	40	2100	200	2100	200	2000	200	1900	250	2600	200	2600	200	2600	200	2600	250
	75	2100	200	1900	200	1700	250	1500	250	2600	200	2600	200	2300	250	2100	250
	90	2000	200	1800	200	1600	250	1400	250	2600	200	2500	200	2200	250	2000	250
120x45	30	3200	250	3100	250	3000	250	2700	250	3900	250	3900	250	3900	250	3700	250
	40	3200	250	3100	250	2700	250	2500	250	3900	250	3900	250	3700	250	3400	250
	75	2800	200	2600	250	2200	250	2000	200	3800	200	3500	250	3100	250	2800	200
	90	2600	250	2400	250	2100	250	1900	200	3600	250	3300	250	2900	250	2600	200
Wind classification C1-C3																	
90x35	30	1800	200	1800	200	1800	200	1500	200	2300	200	2300	200	1800	200	1500	200
	40	1800	200	1800	200	1800	200	1500	200	2300	200	2300	200	1800	200	1500	200
	75	1800	200	1800	200	1500	200	1400	200	2300	200	2300	200	1900	200	1600	200
	90	1800	200	1700	200	1500	200	1300	200	2300	200	2300	200	1800	200	1600	200
120x35	30	2800	250	2800	250	2500	250	2100	200	3500	250	3200	250	2500	250	2100	200
	40	2800	250	2800	250	2500	250	2100	200	3500	250	3200	250	2500	250	2100	200
	75	2600	250	2400	200	2100	200	1900	200	3500	250	3200	200	2600	200	2200	200
	90	2400	250	2200	200	1900	200	1800	200	3300	250	3000	200	2500	200	2100	200
90x45	30	2100	200	2100	200	2000	200	1700	200	2600	200	2600	200	2100	200	1700	200
	40	2100	200	2100	200	2000	200	1800	250	2600	200	2600	200	2100	200	1800	250
	75	2100	200	1900	200	1700	250	1500	250	2600	200	2600	200	2200	250	1800	250
	90	2000	200	1800	200	1600	250	1400	250	2600	200	2500	200	2100	250	1800	250
120x45	30	3200	250	3100	250	2800	250	2300	250	3900	250	3600	250	2800	250	2300	250
	40	3200	250	3100	250	2700	250	2400	250	3900	250	3700	250	2900	250	2400	250
	75	2800	200	2600	250	2200	250	2000	200	3800	200	3500	250	3000	250	2500	200
	90	2600	250	2400	250	2100	250	1900	200	3600	250	3300	250	2900	250	2400	200

NOTES:

1. D = member depth, B = member breadth, NS = not suitable.
2. The above table was based on a batten spacing of 900 mm
3. Maximum birdsmouth depth = 30 % of rafter depth
4. End bearing lengths = 35 mm at end supports and 35 mm at internal supports for continuous members. Subscript values Indicate the minimum additional bearing length where required to be greater than 35 mm at end supports and 35 mm at Internal supports
5. Construction loads shall not be applied to overhangs until a 190x19 (minimum) timber fascia or other fascia of equivalent stiffness is rigidly and permanently attached to the end of rafter overhangs
6. Rafter spacing up to 1200 mm
7. **Not all sizes of SmartLVL in this table are stocked in each state.**

Single/continuous span roof rafter - without ceiling attached

AS 4055 classification N1-N4 & C1-C3

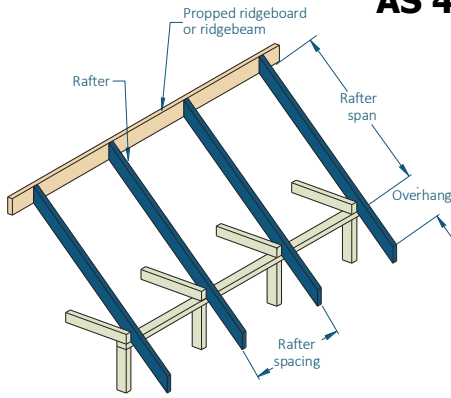

Maximum Birdsmouth = 30% of rafter depth

EXAMPLE:

wind speed = N3

sheet roof - 40 kg/m²

rafter/truss spacing = 600 mm

rafter span = 2400 mm (single span)

Enter span table at rafter spacing of 600 mm, and read down to a span equal to or greater than 2400 mm in the 40 kg/m² row

ADOPT:

Smart10 LVL - 120 x 35

Wind classification N1-N4																	
Rafter Spacing (mm)		450		600		900		1200		450		600		900		1200	
Size DxB (mm)	Roof & ceiling mass (kg/m ²)	Span	O/H	Span	O/H	Span	O/H	Span	O/H	Span	O/H	Span	O/H	Span	O/H	Span	O/H
Maximum recommended single span										Maximum recommended continuous span							
90x35	10	1800	250	1800	200	1800	200	1800	200	2200	250	2300	200	2300	200	2200	200
	20	1800	200	1800	200	1800	200	1800	200	2200	200	2300	200	2300	200	2300	200
	40	1800	200	1800	200	1800	200	1700	200	2300	200	2300	200	2300	200	2300	200
	60	1800	200	1800	200	1700	200	1500	200	2300	200	2300	200	2300	200	2100	200
120x35	10	2800	250	2800	250	2700	250	2600	250	3500	250	3500	250	3500	250	3100	250
	20	2800	250	2800	250	2700	250	2600	250	3500	250	3500	250	3500	250	3200	250
	40	2800	250	2800	250	2500	250	2300	200	3500	250	3500	250	3500	250	3200	200
	60	2800	250	2500	250	2200	200	2000	200	3500	250	3500	250	3000	200	2800	200
90x45	10	2100	200	2100	200	2000	200	2000	200	2600	200	2600	200	2600	200	2600	200
	20	2100	200	2100	200	2000	200	2000	200	2600	200	2600	200	2600	200	2600	200
	40	2100	200	2100	200	2000	200	1900	250	2600	200	2600	200	2600	200	2600	250
	60	2100	200	2100	200	1800	250	1600	250	2600	200	2600	200	2500	250	2200	250
120x45	10	3200	250	3100	250	3000	250	3000	200	4000	250	4000	250	4000	250	3600	200
	20	3200	250	3100	250	3000	200	3000	250	4000	250	4000	250	4000	200	3700	250
	40	3200	250	3100	250	2700	250	2500	250	3900	250	3900	250	3700	250	3400	250
	60	3000	250	2700	200	2400	250	2200	250	3900	250	3700	200	3300	250	3000	250
Wind classification C1-C3																	
90x35	10	1800	250	1800	200	1700	200	1500	200	2300	250	2300	200	1700	200	1500	200
	20	1800	200	1800	200	1800	200	1500	200	2300	200	2300	200	1800	200	1500	200
	40	1800	200	1800	200	1800	200	1500	200	2300	200	2300	200	1800	200	1500	200
	60	1800	200	1800	200	1700	200	1500	200	2300	200	2300	200	1800	200	1600	200
120x35	10	2800	250	2800	250	2400	250	2000	250	3500	250	3100	250	2400	250	2000	250
	20	2800	250	2800	250	2400	250	2000	250	3500	250	3100	250	2400	250	2000	250
	40	2800	250	2800	250	2500	250	2100	200	3500	250	3200	250	2500	250	2100	200
	60	2800	250	2500	250	2200	200	2000	200	3500	250	3300	250	2600	200	2100	200
90x45	10	2100	200	2100	200	2000	200	1700	200	2600	200	2600	200	2000	200	1700	200
	20	2100	200	2100	200	2000	200	1700	200	2600	200	2600	200	2000	200	1700	200
	40	2100	200	2100	200	2000	200	1800	250	2600	200	2600	200	2100	200	1800	250
	60	2100	200	2100	200	1800	250	1600	250	2600	200	2600	200	2100	250	1800	250
120x45	10	3200	250	3100	250	2800	250	2300	200	3900	250	3500	250	2800	250	2300	200
	20	3200	250	3100	250	2800	200	2300	250	3900	250	3600	250	2800	200	2300	250
	40	3200	250	3100	250	2700	250	2400	250	3900	250	3700	250	2900	250	2400	250
	60	3000	250	2700	200	2400	250	2200	250	3900	250	3700	200	2900	250	2400	250

NOTES:

1. D = member depth, B = member breadth, NS = not suitable.
2. The above table was based on a batten spacing of 900 mm
3. Maximum birdsmouth depth = 30 % of rafter depth
4. End bearing lengths = 35 mm at end supports and 35 mm at internal supports for continuous members. Subscript values indicate the minimum additional bearing length where required to be greater than 35 mm at end supports and 35 mm at internal supports
5. Construction loads shall not be applied to overhangs until a 190x19 (minimum) timber fascia or other fascia of equivalent stiffness is rigidly and permanently attached to the end of rafter overhangs
6. Rafter spacing up to 1200 mm
7. **Not all sizes of SmartLVL in this table are stocked in each state.**

Ceiling joists

AS 4055 wind classification N1-N3 and C1-C3

Ceiling mass 20 kg/m²

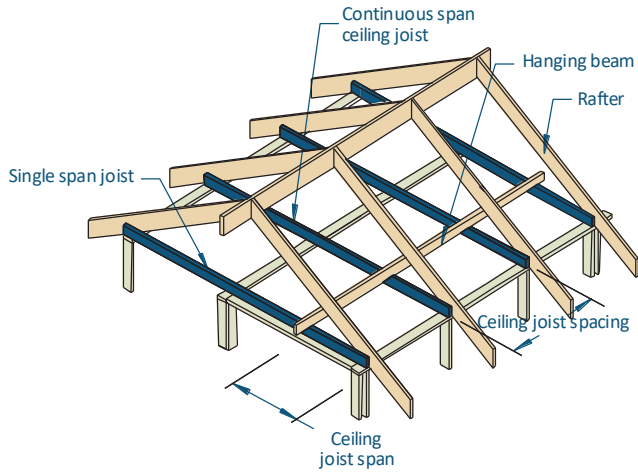

EXAMPLE:

wind speed = N3

ceiling mass = 20 kg/m²

ceiling Joist span = 3000 mm (single span)

ceiling Joist spacing = 450 mm

Enter single span table at 450 mm in joist spacing column, read down to a span equal to or greater than 3000 mm

ADOPT:

Smart10 LVL - 120 x 35

Ceiling joist spacing (mm)	450	600	900	1200	450	600	900	1200
Size DxB (mm)	Maximum recommended single span				Maximum recommended continuous span			
90x35	2600	2400	2100	1800	3300	2800	2200	1800
120x35	3500	3200	2900	2500	4500	3800	3000	2500
90x45	2800	2600	2300	2100	3800	3200	2500	2100
120x45	3700	3400	3100	2800	5000	4400	3500	2900

NOTES:

1. D = member depth, B = member breadth
2. Do not walk on joists during construction unless a construction plank is in place or over batten minimum of 35 x 70 F5
3. Minimum end/internal bearing length of 70 mm
4. **Not all sizes of SmartLVL in this table are stocked in each state. Please check with your supplier before ordering.**

SMARTFRAME[®]
POWERED BY INNOVATION



Sales 1800 33 77 03
Technical support 1300 666 690



tilling.com.au