

SmartJoist Rafter Box-Gutter

- NOTE:
1) All tie-downs to be designed to AS 1684.2 for the respective wind loads
2) Tie-down straps & bracings are NOT to be supplied by Tilling Timber Pty Ltd.

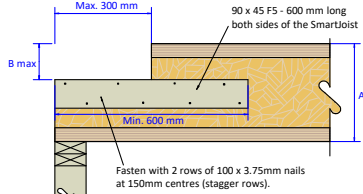

A = 200*, 240, 255 & 300 mm depth
B = 50 mm when A = 240 and 255 mm
B = 100 mm when A = 300 mm

*200 mm - Requires ply infill, 90 x 45 solid timber reinforcement is not suitable
Refer to detail BG2 for Box gutter rebate on S120044.

SmartJoist Box Gutter Rebate With Pine Reinforcement
BG1

- NOTE:
1) All tie-downs to be designed to AS 1684.2 for the respective wind loads
2) Tie-down straps & bracings are NOT to be supplied by Tilling Timber Pty Ltd.

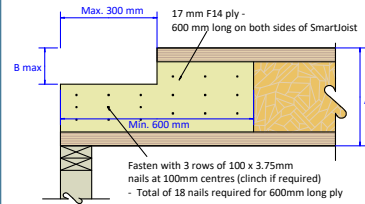

A = 200, 240, 255 & 300 mm depth
B = 50 mm when A = 240 and 255 mm
B = 100 mm when A = 300 mm

SmartJoist Box Gutter Rebate With Ply Reinforcement
BG2

SmartJoist, SmartLVL & SmartLam GLT Rafter Cut

- NOTE:
1) All tie-downs to be designed to AS 1684.2 for the respective wind loads
2) Tie-down straps & bracings are NOT to be supplied by Tilling Timber Pty Ltd.

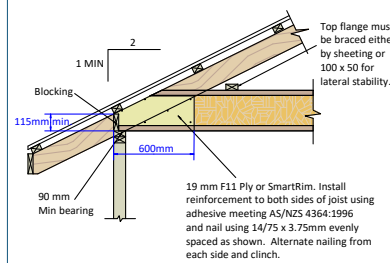

SmartJoist Rafter Cut
F26

- NOTE:
1) All tie-downs to be designed to AS 1684.2 for the respective wind loads
2) Tie-down straps & bracings are NOT to be supplied by Tilling Timber Pty Ltd.

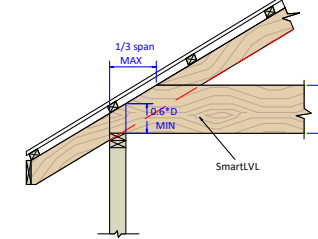

SmartLVL Rafter Cut
F26A

- NOTE:
1) All tie-downs to be designed to AS 1684.2 for the respective wind loads
2) Tie-down straps & bracings are NOT to be supplied by Tilling Timber Pty Ltd.

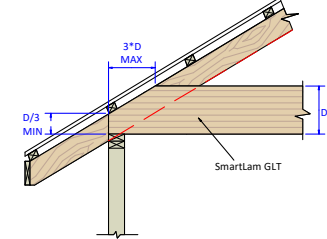

SmartLam GLT Rafter Cut
F26B

SmartJoist Birdsmouth Cut & Bevel Cut

- NOTE:
1) All tie-downs to be designed to AS 1684.2 for the respective wind loads
2) Tie-down straps & bracings are NOT to be supplied by Tilling Timber Pty Ltd.

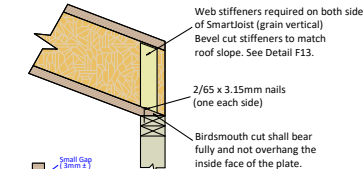

(At low end of joist ONLY)
(Limited to max. 600mm overhang)

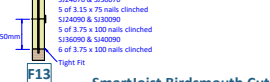

SmartJoist Birdsmouth Cut
R1

- NOTE:
1) All tie-downs to be designed to AS 1684.2 for the respective wind loads
2) Tie-down straps & bracings are NOT to be supplied by Tilling Timber Pty Ltd.

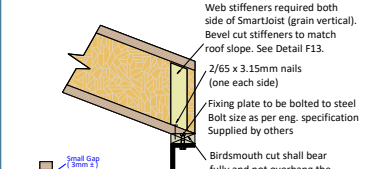

(At low end of joist ONLY)
(Limited to max. 600mm overhang)

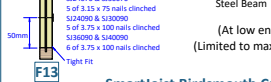

SmartJoist Birdsmouth Cut
R1A

- NOTE:
1) All tie-downs to be designed to AS 1684.2 for the respective wind loads
2) Tie-down straps & bracings are NOT to be supplied by Tilling Timber Pty Ltd.

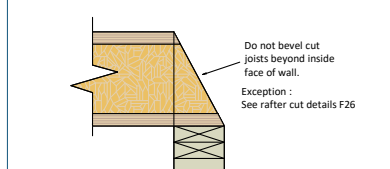

NOTE:
SmartJoist blocking is required at bearing to provide lateral support

SmartJoist Bevel Cut
R2

SmartJoist Rafter to Ridge Beam

- NOTE:
1) All tie-downs to be designed to AS 1684.2 for the respective wind loads
2) Tie-down straps & bracings are NOT to be supplied by Tilling Timber Pty Ltd.

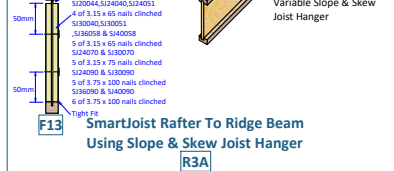
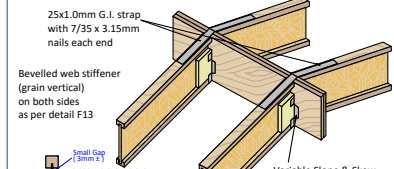

SmartJoist Rafter to Ridge Beam
Using Face Mount Joist Hanger
R3B

Outriggers to SmartJoist Rafter

- NOTE:
1) All tie-downs to be designed to AS 1684.2 for the respective wind loads
2) Tie-down straps & bracings are NOT to be supplied by Tilling Timber Pty Ltd.

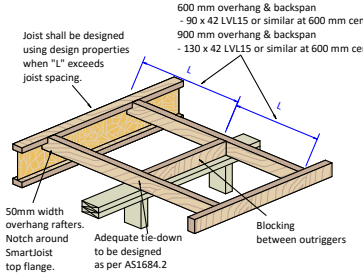

Outriggers to SmartJoist Rafter
R4

SmartJoist Rafter With Overhang On Bevelled Plate

- NOTE:
1) All tie-downs to be designed to AS 1684.2 for the respective wind loads
2) Tie-down straps & bracings are NOT to be supplied by Tilling Timber Pty Ltd.

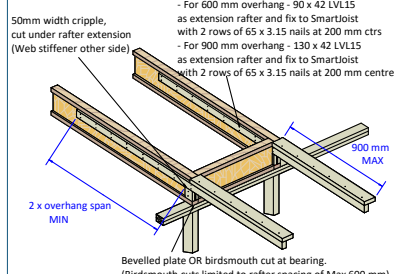

SmartJoist Rafter With Solid Section Overhang
On Bevelled Plate or With Birdsmouth Cut
R5A

- NOTE:
1) All tie-downs to be designed to AS 1684.2 for the respective wind loads
2) Tie-down straps & bracings are NOT to be supplied by Tilling Timber Pty Ltd.

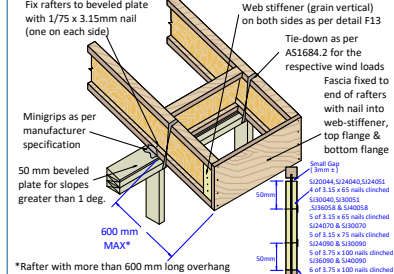

SmartJoist Rafter On Bevelled Plate With Overhang
R5B

- NOTE:
1) All tie-downs to be designed to AS 1684.2 for the respective wind loads
2) Tie-down straps & bracings are NOT to be supplied by Tilling Timber Pty Ltd.

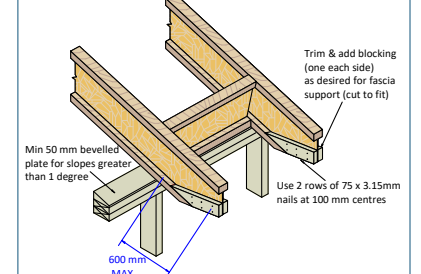

SmartJoist Rafter On Bevelled Plate
With Soffit Cut Overhang
R5C

SmartJoist Rafter Overhang With Birdsmouth

NOTE:
1) All tie-downs to be designed to AS 1684.2 for the respective wind loads
2) Tie-down straps & bracings are NOT to be supplied by Tilling Timber Pty Ltd.

Web stiffeners required both sides as per detail F13

90 x 45 extension rafter on both sides for fascia support (cut to fit). Fixed with 2 rows of 3.15 x 75mm long nails at 100 mm centres.

600 mm MAX

Birdsmouth cut at bearing. (Limited to rafters spaced at a MAX of 600 mm)

SmartJoist Rafter With Soffit Overhang & Birdsmouth Cut **R6A**

Small Gap [1.0mm]	SJ20044, SJ24040, SJ24051
4 of 3.15 x 65 nails clinched	SJ30040, SJ30051
5 of 3.15 x 65 nails clinched	SJ24070 & SJ24071
5 of 3.15 x 75 nails clinched	SJ24090 & SJ30090
5 of 3.75 x 100 nails clinched	SJ36090 & SJ40090
6 of 3.75 x 100 nails clinched	Right Fit

NOTE:
1) All tie-downs to be designed to AS 1684.2 for the respective wind loads
2) Tie-down straps & bracings are NOT to be supplied by Tilling Timber Pty Ltd.

Web stiffeners required both sides as per detail F13

25x1.0mm G.I. strap with 7/35 x 3.15mm nails each end

600 mm MAX

Birdsmouth cut at bearing. (Limited to rafters spaced at a MAX of 600 mm)

SmartJoist Rafter With Overhang & Birdsmouth Cut **R6B**

Small Gap [3mm]	SJ20044, SJ24040, SJ24051
4 of 3.15 x 65 nails clinched	SJ30040, SJ30051
5 of 3.15 x 65 nails clinched	SJ24070 & SJ24071
5 of 3.15 x 75 nails clinched	SJ24090 & SJ30090
5 of 3.75 x 100 nails clinched	SJ36090 & SJ40090
6 of 3.75 x 100 nails clinched	Right Fit

Peak Connection

NOTE:
1) All tie-downs to be designed to AS 1684.2 for the respective wind loads
2) Tie-down straps & bracings are NOT to be supplied by Tilling Timber Pty Ltd.

Bevelled web stiffener on both sides detail F13

25x1.0mm G.I. strap with 7/35 x 3.15mm nails each end

Variable Slope & Skew Joist Hanger

SmartJoist Rafter Peak Connection With Slope & Skew Joist Hanger **R7A**

Small Gap [2mm]	SJ20044, SJ24040, SJ24051
4 of 3.15 x 65 nails clinched	SJ30040, SJ30051
5 of 3.15 x 65 nails clinched	SJ24070 & SJ24071
5 of 3.15 x 75 nails clinched	SJ24090 & SJ30090
5 of 3.75 x 100 nails clinched	SJ36090 & SJ40090
6 of 3.75 x 100 nails clinched	Right Fit

NOTE:
1) All tie-downs to be designed to AS 1684.2 for the respective wind loads
2) Tie-down straps & bracings are NOT to be supplied by Tilling Timber Pty Ltd.

25x1.0mm G.I. strap with 7/35 x 3.15mm nails each end

Face mount hanger (for roof pitch equal/less than 3 deg ONLY)

SmartJoist Rafter Peak Connection With Face Mount Joist Hanger **R7B**

NOTE:
1) All tie-downs to be designed to AS 1684.2 for the respective wind loads
2) Tie-down straps, multigrrips & bracings are NOT to be supplied by Tilling Timber.

Long multigrip connectors on both sides (always used as pairs). Fix with 5/ 3.15 x 35 galvanised nails into each member

25x1.0mm G.I. strap with 7/35 x 3.15mm nails each end

Bevelled web stiffener on both sides detail F13

For SJ200 rafter - Install 1 long multigrip connector each side

For SJ240, SJ300, SJ360 & SJ400 rafter - Install 2 long multigrip connectors each side

5 nails into each member and 2 nails into the bottom of the beam Nail size: 3.15 x 35mm galvanised

SmartJoist Rafter Peak Connection With Long Multigrip Connector **R7C**

Unless the top of the supported beam is provided with additional lateral restraints such as mini or multi grips, the bracket must cover at least 60% of the supported beam depth.

Birdsmouth cut may be required for roof pitch greater than 3 deg Refer to Section A or B

Birdsmouth cut: D / 3 max. D = Rafter depth

Bracket Code	Fixing to supporting beam (Beam A)	Fixing to supporting beam (Beam B)
FB3590, FB4290	8/35x3.15mm nails	4/35x3.15mm nails
FB4590, FB5890	12/35x3.15mm nails	6/35x3.15mm nails
FB3520, FB42120	12/35x3.15mm nails	6/35x3.15mm nails
FB45120, FB58120 & FB60130	12/35x3.15mm nails	10/35x3.15mm nails
FB35180, FB42170 & FB45180	10/35x3.15mm nails	10/35x3.15mm nails
FB58170, FB65170	18/35x3.15mm nails	6/35x3.15mm nails
FB42220, FB45220	12/35x3.15mm nails	12/35x3.15mm nails
FB35200, FB40200	12/35x3.15mm nails	12/35x3.15mm nails
FB58200	12/35x3.15mm nails	12/35x3.15mm nails
FB60220	12/35x3.15mm nails	13/35x3.15mm nails

SmartLVL Rafter Peak Connection With Face Mount Hanger **R7D**

NOTE:
1) All tie-downs to be designed to AS 1684.2 for the respective wind loads
2) Tie-down straps, multigrrips & bracings are NOT to be supplied by Tilling Timber.

2 Long multigrip connectors on both sides (always used as pairs). 5/ 3.15 x 35 galvanised nails into each member

For LVL rafter depth between 200-200mm - Install 1 long multigrip connector each side

For LVL rafter depth between 200-400mm - Install 2 long multigrip connectors each side

25x1.0mm G.I. strap with 7/35 x 3.15mm nails each end

5 nails into each member and 2 nails into the bottom of the beam Nail size: 3.15 x 35mm galvanised

SmartLVL Rafter Peak Connection With Long Multigrip Connectors **R7E**

Lateral Restraint At Support

NOTE:
1) All tie-downs to be designed to AS 1684.2 for the respective wind loads
2) Tie-down straps & bracings are NOT to be supplied by Tilling Timber Pty Ltd.

Rim Board Blocking. (Toe nail to top plate at 150mm ctrs). Install as joists are set.

Web stiffeners required both sides as per detail F13

Bevelled plate or Birdsmouth cut at bearing

SmartJoist Rafter Lateral Support With SmartRim Blocking Panel **R9A**

Small Gap [2mm]	SJ20044, SJ24040, SJ24051
4 of 3.15 x 65 nails clinched	SJ30040, SJ30051
5 of 3.15 x 65 nails clinched	SJ24070 & SJ24071
5 of 3.15 x 75 nails clinched	SJ24090 & SJ30090
5 of 3.75 x 100 nails clinched	SJ36090 & SJ40090
6 of 3.75 x 100 nails clinched	Right Fit

NOTE:
1) All tie-downs to be designed to AS 1684.2 for the respective wind loads
2) Tie-down straps & bracings are NOT to be supplied by Tilling Timber Pty Ltd.

Fix roof batten to rafter with 2/35 x 3.15 nails

Fix roof batten to blocking with 4/35 x 3.15 nails

Fix cut-to-length blocking to support with 4/65 x 3.15mm nail per each blocking

Bevelled plate or Birdsmouth cut at bearing Birdsmouth cut limited to rafters spaced at a MAX of 600 mm

SmartJoist Rafter Lateral Support With SmartJoist Blocking Panel **R9B**

NOTE:
1) All tie-downs to be designed to AS 1684.2 for the respective wind loads
2) Tie-down straps & bracings are NOT to be supplied by Tilling Timber Pty Ltd.

Roof batten to rafter fixing as per AS1684.2

Nail metal strap to rafters and supports with 3/75 x 3.15mm nails

Bevelled plate or Birdsmouth cut at bearing Birdsmouth cut limited to rafters spaced at a MAX of 600 mm

SmartJoist Rafter Lateral Support With Metal Straps **R9C**

SmartJoist Rafter On Bevelled Plate

NOTE:
1) All tie-downs to be designed to AS 1684.2 for the respective wind loads
2) Tie-down straps & bracings are NOT to be supplied by Tilling Timber Pty Ltd.

Panel backer block on both sides with 18 nails

Bevelled plate only Birdsmouth cut not permitted.

Twist strap on both sides No. of nails & nail size as per manufacturer specification

30 degrees max. angle

SmartJoist Rafter Peak Connection **R8**

NOTE:
1) All tie-downs to be designed to AS 1684.2 for the respective wind loads
2) Tie-down straps & bracings are NOT to be supplied by Tilling Timber Pty Ltd.

25 x 1.0 mm G.I. strap with 7/35 x 3.15 nails each end

Fix rafters to support with 1/75 x 3.15mm nail (one on each side)

Double-bevelled plate on beam or wall

Tie-down as per AS1684.2

SmartJoist Rafter On Bevelled Plate With Tie-Down Straps **R10A**

NOTE:
1) All tie-downs to be designed to AS 1684.2 for the respective wind loads
2) Tie-down straps & bracings are NOT to be supplied by Tilling Timber Pty Ltd.

600mm

Blocking panel

RimBoard or filler block on both sides. (With 12 nails on each side of ridge)

Double-bevelled plate on beam or wall

SmartJoist Rafter On Bevelled Plate With Ply Reinforcement **R10B**

Roof Opening

NOTE:
1) All tie-downs to be designed to AS 1684.2 for the respective wind loads
2) Tie-down straps & bracings are NOT to be supplied by Tilling Timber Pty Ltd.

Backer block (Min. 250mm long) fixed to BOTH SIDES of the SmartJoist with 10/3.75x75mm nails each side (clinched if required)

Face-mount hanger

25x1.0mm G.I. strap with 7/35 x 3.15mm nails each end

Backer block (Min. 250mm long) fixed to BOTH SIDES of the SmartJoist with 10/3.75x75mm nails each side (clinched if required)

SmartJoist Rafter Roof Opening **R11**

NOTE:
1) All tie-downs to be designed to AS 1684.2 for the respective wind loads
2) Tie-down straps & bracings are NOT to be supplied by Tilling Timber Pty Ltd.

Backer block (Min. 250mm long) fixed to BOTH SIDES of the SmartJoist with 10/3.75x75mm nails each side (clinched if required)

Face-mount hanger

25x1.0mm G.I. strap with 7/35 x 3.15mm nails each end

Backer block (Min. 250mm long) fixed to BOTH SIDES of the SmartJoist with 10/3.75x75mm nails each side (clinched if required)

SmartJoist Rafter Roof Opening **R11A**

Lateral Restraint With Ceiling Attached

NOTE:
1) All tie-downs to be designed to AS 1684.2 for the respective wind loads
2) Tie-down straps & bracings are NOT to be supplied by Tilling Timber Pty Ltd.

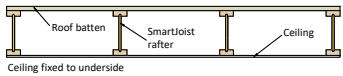
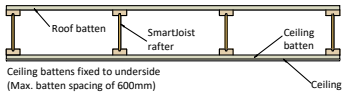

Ceiling/Ceiling Batten To SmartJoist Rafter

R12

NOTE:
1) All tie-downs to be designed to AS 1684.2 for the respective wind loads
2) Tie-down straps & bracings are NOT to be supplied by Tilling Timber Pty Ltd.

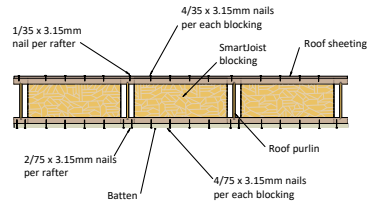

Lateral Restraint SmartJoist Purlin

R9D

NOTE:
1) All tie-downs to be designed to AS 1684.2 for the respective wind loads
2) Tie-down straps & bracings are NOT to be supplied by Tilling Timber Pty Ltd.

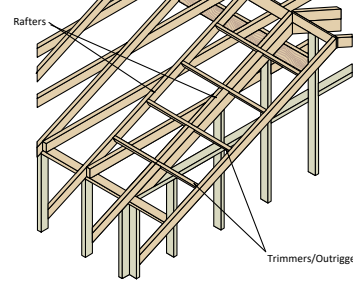

Outriggers To SmartLVL Rafter

R13

Tie-Down For SmartJoist Rafter

NOTE:
1) All tie-downs to be designed to AS 1684.2 for the respective wind loads
2) Tie-down straps & bracings are NOT to be supplied by Tilling Timber Pty Ltd.

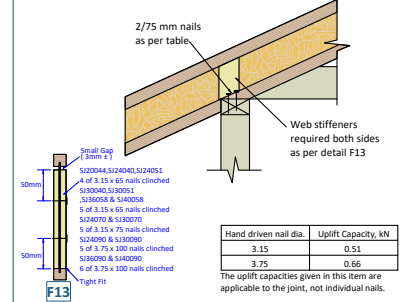

SmartJoist Rafter Tie-Down With Skew Nails

R14A

NOTE:
1) All tie-downs to be designed to AS 1684.2 for the respective wind loads
2) Tie-down straps & bracings are NOT to be supplied by Tilling Timber Pty Ltd.

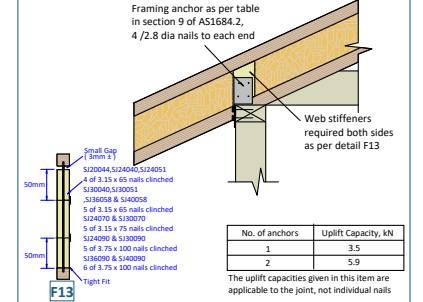

SmartJoist Rafter Tie-Down With Framing Anchor

R14B

Tie-Down For SmartJoist/SmartLVL Rafter

NOTE:
1) All tie-downs to be designed to AS 1684.2 for the respective wind loads
2) Tie-down straps & bracings are NOT to be supplied by Tilling Timber Pty Ltd.

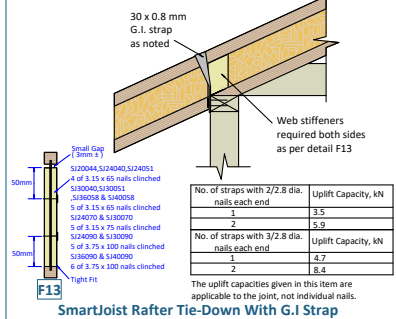

SmartJoist Rafter Tie-Down With G.I. Strap

R14C

NOTE:
1) All tie-downs to be designed to AS 1684.2 for the respective wind loads
2) Tie-down straps & bracings are NOT to be supplied by Tilling Timber Pty Ltd.

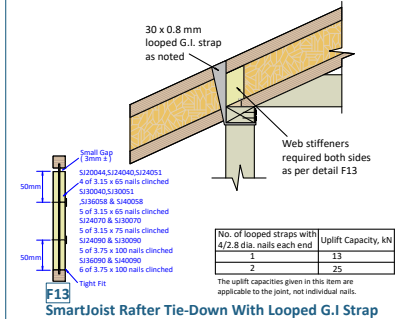

SmartJoist Rafter Tie-Down With Looped G.I. Strap

R14D

NOTE:
1) All tie-downs to be designed to AS 1684.2 for the respective wind loads
2) Tie-down straps & bracings are NOT to be supplied by Tilling Timber Pty Ltd.

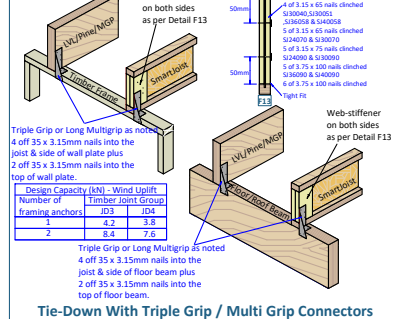

Tie-Down With Triple Grip / Multi Grip Connectors

R14E

Rafter Overhang With/Without Bevelled Plate

NOTE:
1) All tie-downs to be designed to AS 1684.2 for the respective wind loads
2) Tie-down straps & bracings are NOT to be supplied by Tilling Timber Pty Ltd.

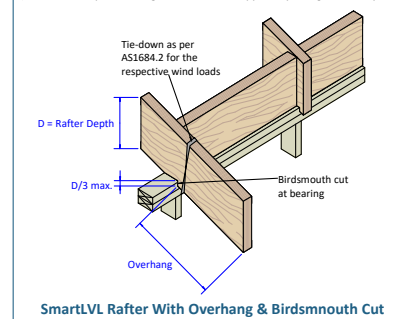

SmartLVL Rafter With Overhang & Birdsmouth Cut

R6C

NOTE:
1) All tie-downs to be designed to AS 1684.2 for the respective wind loads
2) Tie-down straps & bracings are NOT to be supplied by Tilling Timber Pty Ltd.

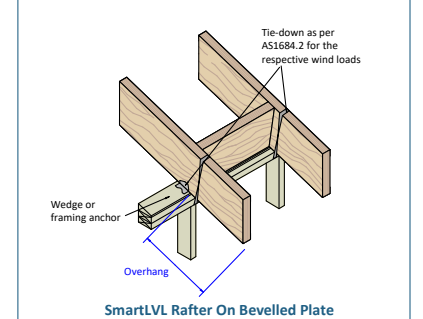

SmartLVL Rafter On Bevelled Plate

R5D

Roof Beam Lateral Restraint

NOTE:
1) All tie-downs to be designed to AS 1684.2 for the respective wind loads
2) Tie-down straps & bracings are NOT to be supplied by Tilling Timber Pty Ltd.

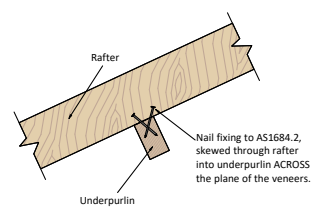

SmartLVL Rafter To Underpurlin

R15

NOTE:
1) All tie-downs to be designed to AS 1684.2 for the respective wind loads
2) Tie-down straps & bracings are NOT to be supplied by Tilling Timber Pty Ltd.

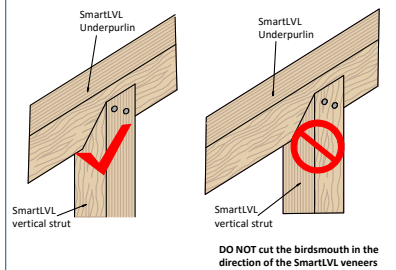

Vertical SmartLVL Roof Struts

R16

NOTE:
1) All tie-downs to be designed to AS 1684.2 for the respective wind loads
2) Tie-down straps & bracings are NOT to be supplied by Tilling Timber Pty Ltd.

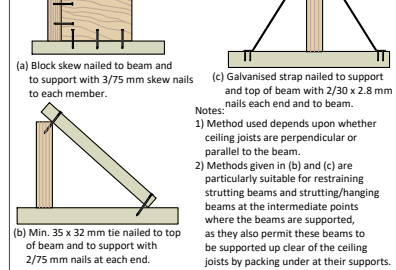

Lateral Restraint of Hanging, Counter, Strutting, Hanging/Counter Beams

R17

NOTE:
1) All tie-downs to be designed to AS 1684.2 for the respective wind loads
2) Tie-down straps & bracings are NOT to be supplied by Tilling Timber Pty Ltd.

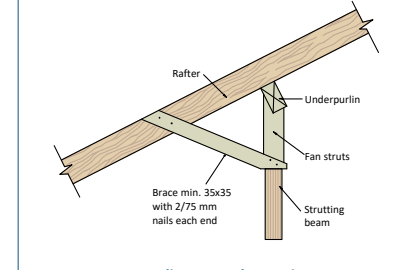

Intermediate Lateral Restraint For Strutting Beam Perpendicular to Underpurlin

R18A

NOTE:
1) All tie-downs to be designed to AS 1684.2 for the respective wind loads
2) Tie-down straps & bracings are NOT to be supplied by Tilling Timber Pty Ltd.

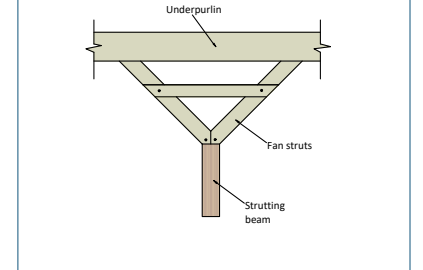

Intermediate Lateral Restraint For Strutting Beam Parallel to Underpurlin

R18B