

## TECBEAM FLOOR/ROOF DETAILS

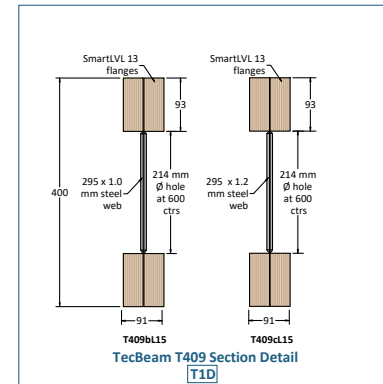

<p><b>TecBeam Section Details</b></p> <p><a href="#">T1A</a>    <a href="#">T1B</a> <a href="#">T1C</a> <a href="#">T1D</a>                  TB25    TB30 TB36 TB40                  &amp; TB26</p> <p><b>Strongback Fixing Details</b></p> <p><a href="#">T3A</a>    <a href="#">T3B</a>                  Timber    Steel</p> <p><b>Flat Roof Framing &amp; Box-Gutter</b></p> <p><a href="#">T5A</a>    <a href="#">T5B</a>                  Flat Roof    Box-Gutter                  Framing</p> <p><b>TecBeam To Timber Beam Details</b></p> <p><a href="#">T8A</a> <a href="#">T8B</a>    <a href="#">T8C</a>    <a href="#">T8D</a> <a href="#">T8E</a> <a href="#">T8F</a>                  FM    Inverted With Web With LVSIA LVSIA                  FM    Stiffener    Strap    300</p> <p><b>TecBeam Check Into Steel Details</b></p> <p><a href="#">T10A</a></p> <p><b>Multiple TecBeams Laminataion Details</b></p> <p><a href="#">T13A</a> <a href="#">T13B</a> <a href="#">T13C</a>    <a href="#">T13D</a>                  UDL    PL    Int. Wall    Ext. Wall</p>	<p><b>Tapered End Details</b></p> <p><a href="#">T2A</a> <a href="#">T2B</a> <a href="#">T2C</a>    <a href="#">T2D</a> <a href="#">T2E</a> <a href="#">T2F</a>    <a href="#">T2G</a> <a href="#">T2H</a> <a href="#">T2I</a>    <a href="#">T2J</a> <a href="#">T2K</a> <a href="#">T2L</a>                  TB25 &amp; TB26    TB30    TB36    TB40</p> <p><b>Load Bearing Strongback Details</b></p> <p><a href="#">T3C</a>    <a href="#">T3D</a>                  Non-Cantilevered    Cantilevered                  Strongback    Strongback</p> <p><b>End Blocking Details</b></p> <p><a href="#">T6A</a> <a href="#">T6B</a>    <a href="#">T6C</a>    <a href="#">T6D</a>                  Solid    SmartJoist    Solid    SmartRim                  Rimjoist</p> <p><b>TB To UB/UC Steel With Bracket</b></p> <p><a href="#">T9A</a> <a href="#">T9B</a> <a href="#">T9C</a> <a href="#">T9D</a> <a href="#">T9E</a> <a href="#">T9F</a>                  FM    FM    FM    TM    FM    TM                  UB    UB    UC    TM    Strap</p> <p><b>Timber Beam To TecBeam Details</b></p> <p><a href="#">T11A</a>    <a href="#">T11B</a>                  Single    Double                  TecBeam    TecBeams</p>	<p><b>Cantilevered TecBeam Details</b></p> <p><a href="#">T4A</a>    <a href="#">T4B</a>    <a href="#">T4C</a>                  Cantilevered    With Extension    Reinforced                  TecBeam    LVL/Pine Joist</p> <p><b>Blockwall Support Details</b></p> <p><a href="#">T7A</a>    <a href="#">T7B</a>    <a href="#">T7C</a>                  Hanger    EA    Full Bear</p> <p><b>TB To PFC Steel With Bracket</b></p> <p><a href="#">T9G</a> <a href="#">T9H</a>    <a href="#">T9I</a>                  FM    TM    FM                  Front    Back</p> <p><b>Web-Stiffener Details</b></p> <p><a href="#">T12A</a>    <a href="#">T12B</a>                  Over    Under PL                  Support    or Wall</p>
--	---	--

## TecBeam Section Details

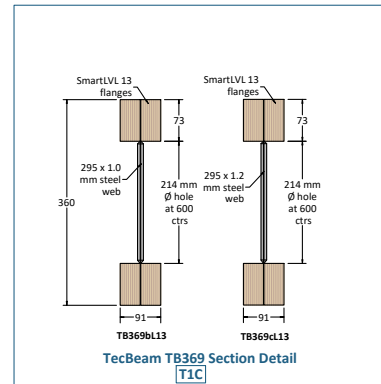
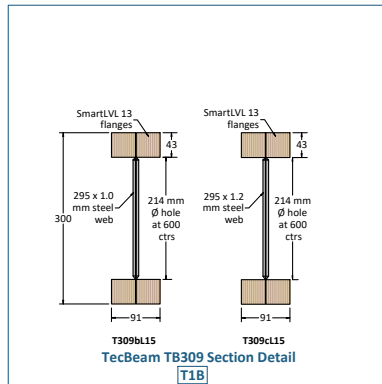
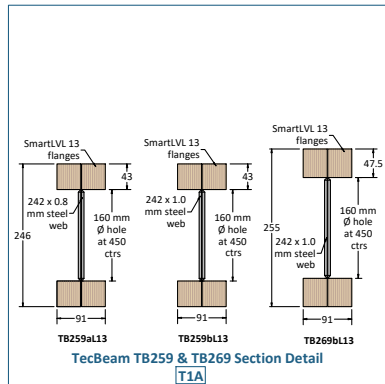

## Strongback Fixing Details

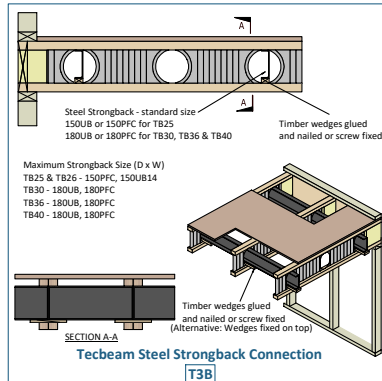
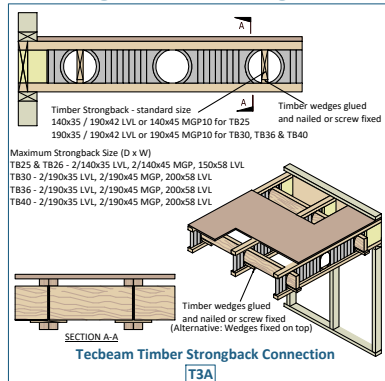

## Load Bearing Strongback

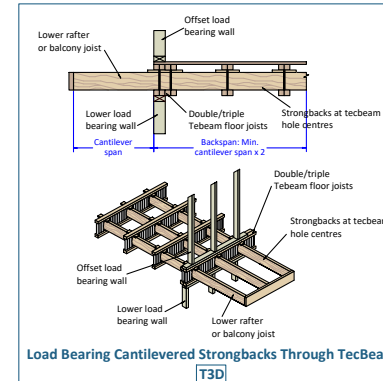
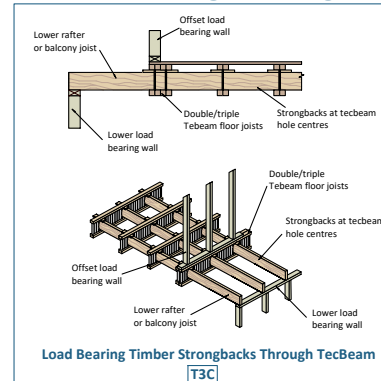

## Cantilevered TecBeam

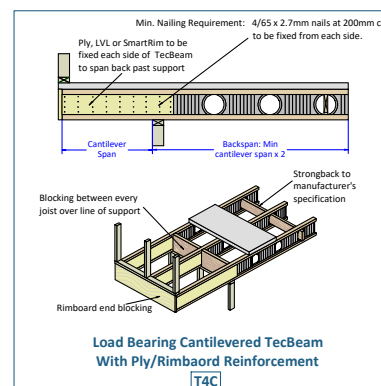
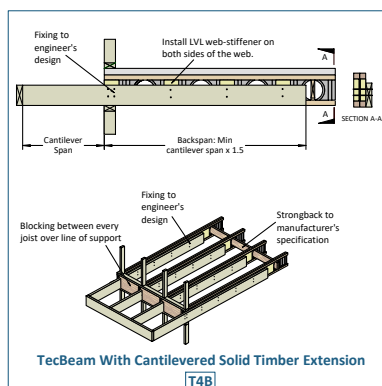
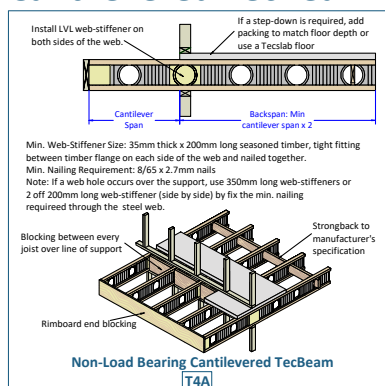

## TecBeam Flat Roof

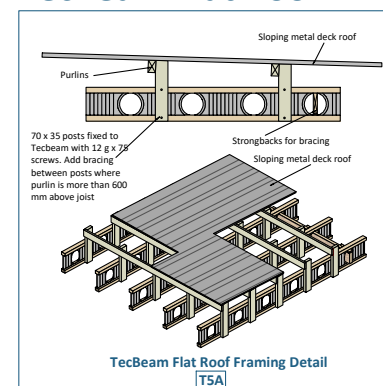

## TecBeam Box-Gutter

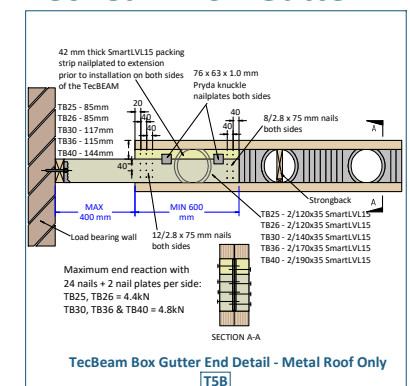

**TecBeam Tapered End Details (TB25 & TB26)**

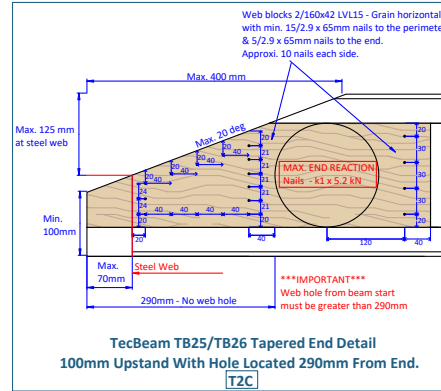
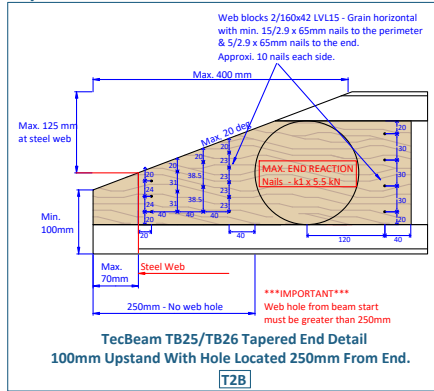
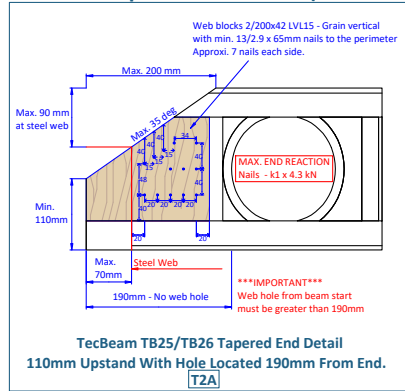

**TecBeam Tapered End Details (TB30)**

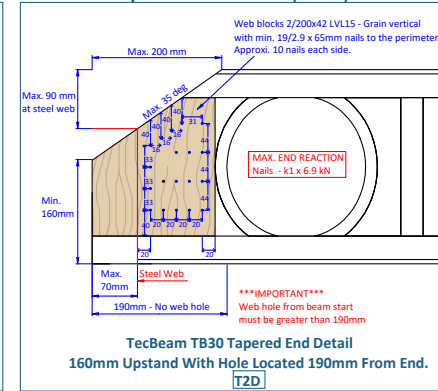

**TecBeam Tapered End Details (TB30)**

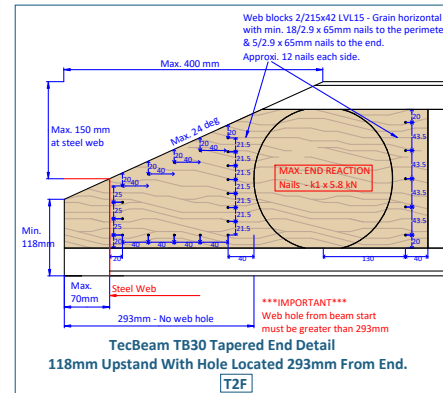
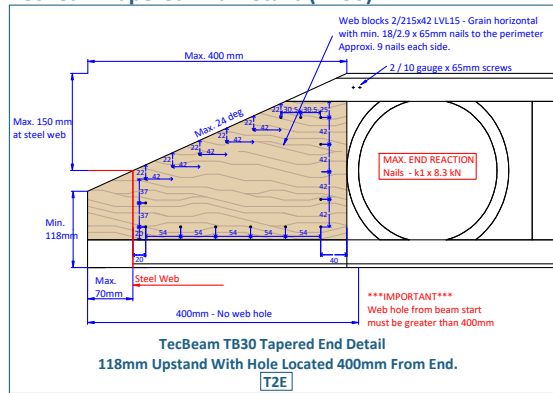

**TecBeam Tapered End Details (TB36)**

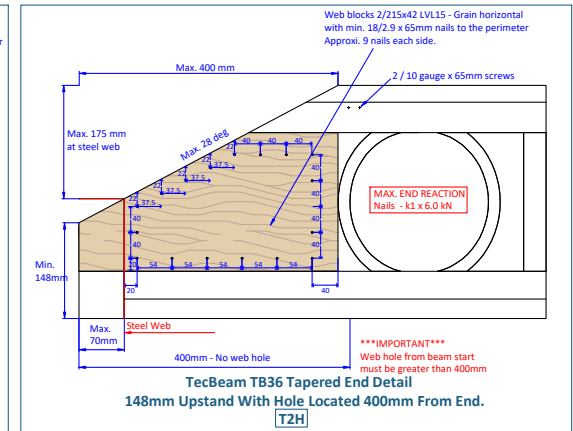
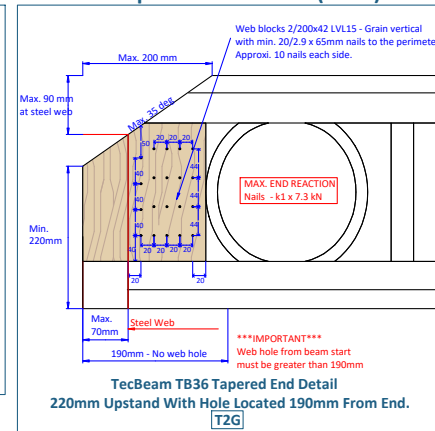

**TecBeam Tapered End Details (TB36)**

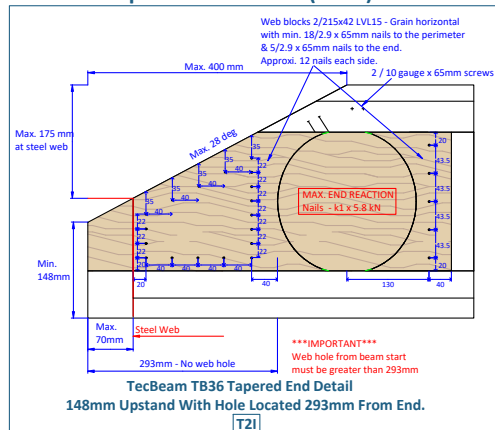

**TecBeam Tapered End Details (TB40)**

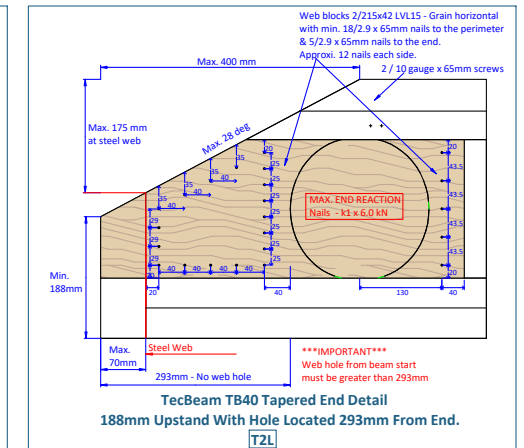
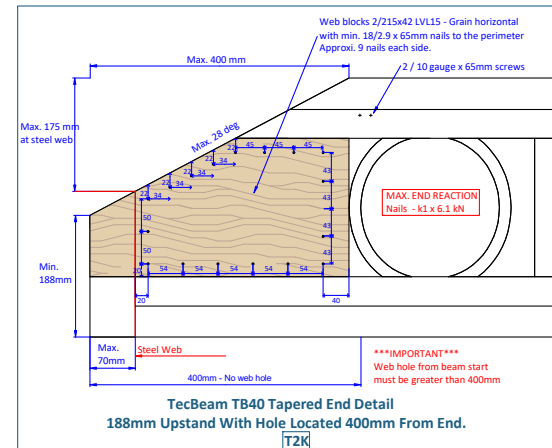
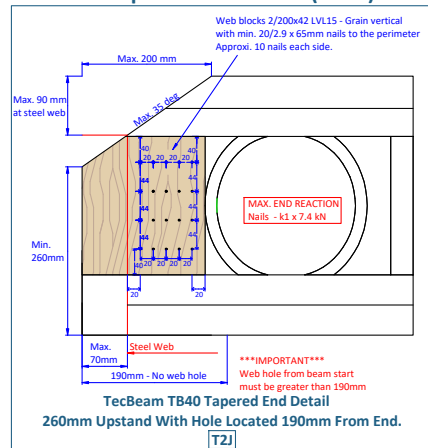

## TecBeam End Blocking Details

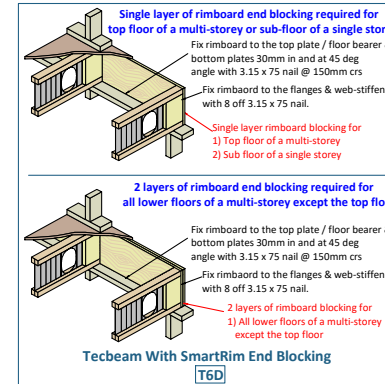
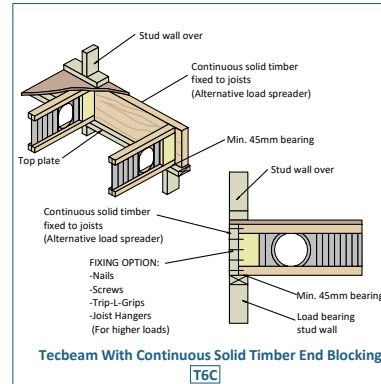
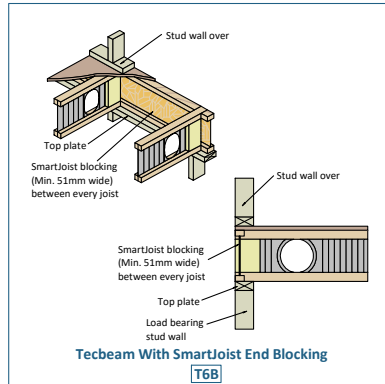
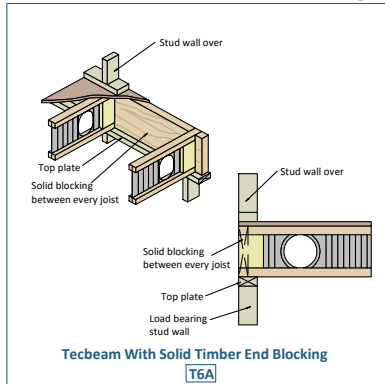

## TecBeam Block Wall Support Details

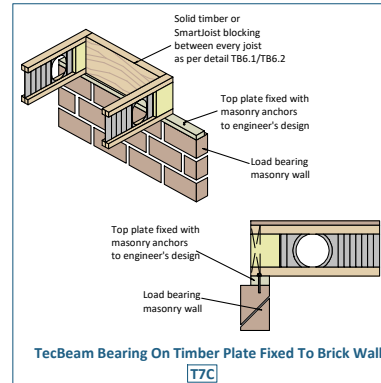
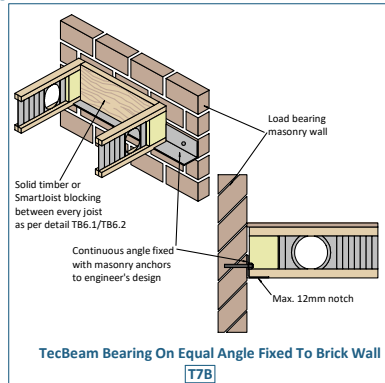
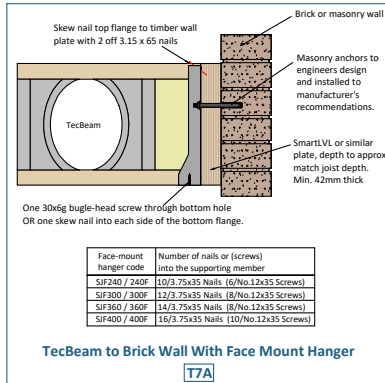

## TecBeam To Timber Beam Using Face-Mount Hanger

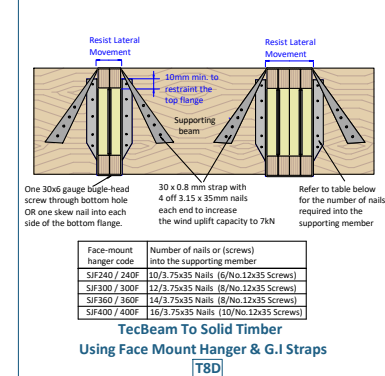
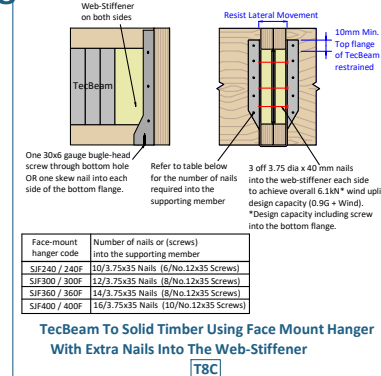
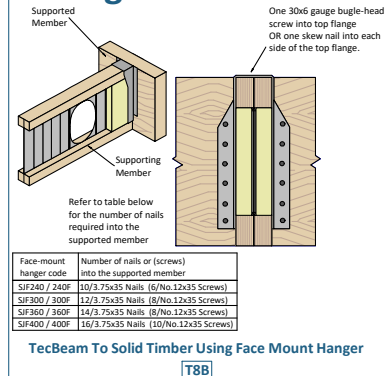
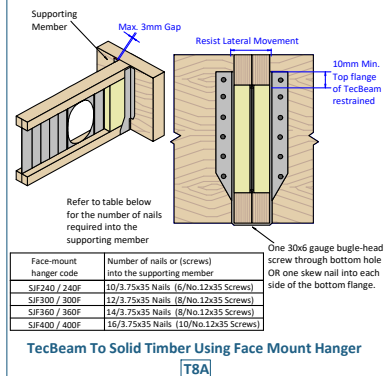

## TecBeam To Timber Beam With LV5IA/LVSIA300

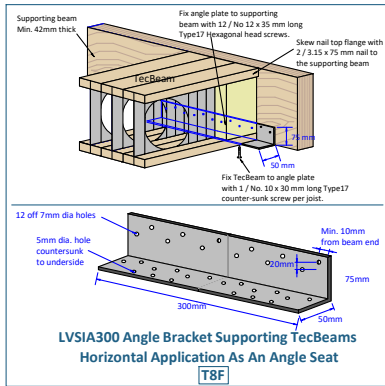
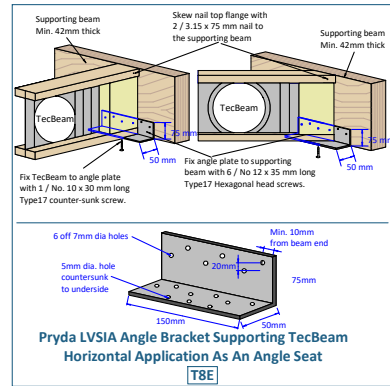

## TecBeam to UB/UC Steel Face/Top Mount Hanger

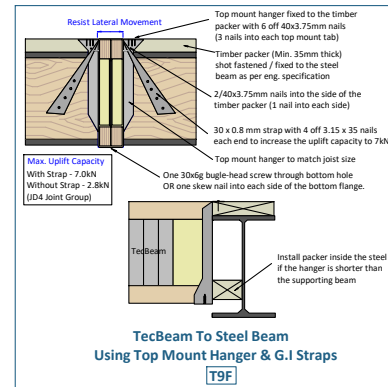
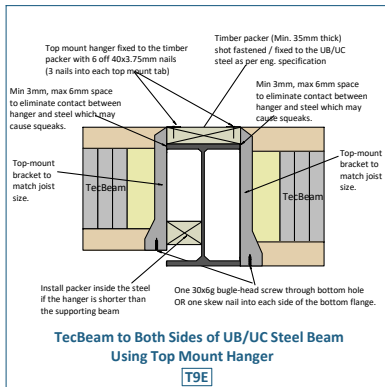
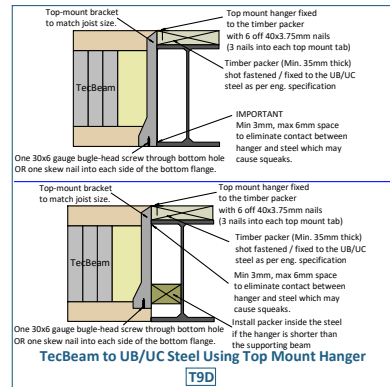
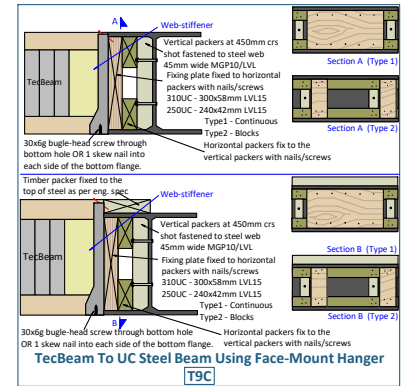
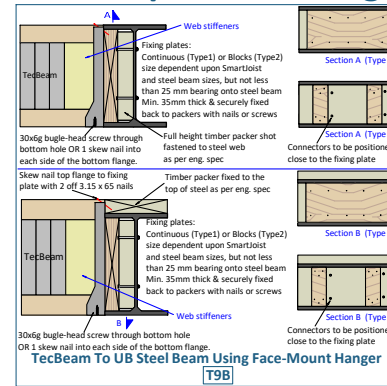
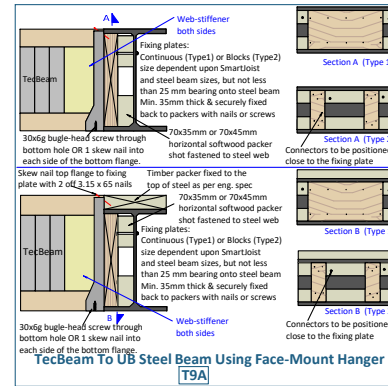

## TecBeam to PFC Steel Face/Top Mount Hanger

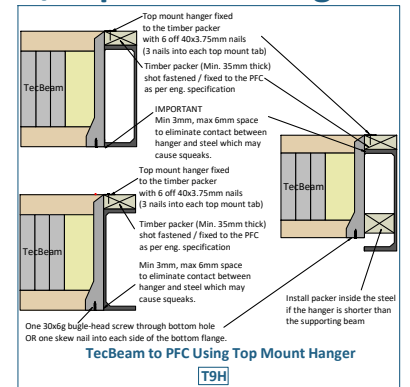
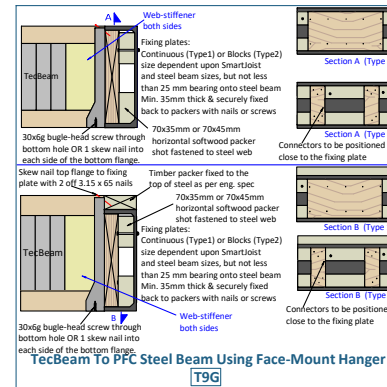

## TecBeam Into Steel

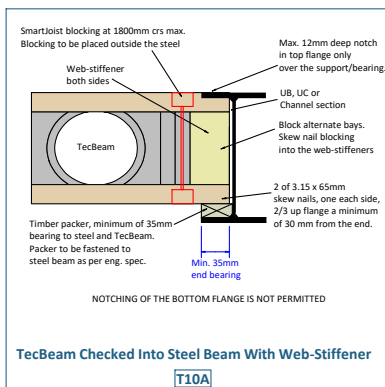
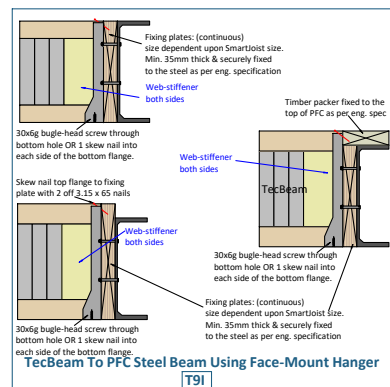

## Solid Timber Beam To TecBeam

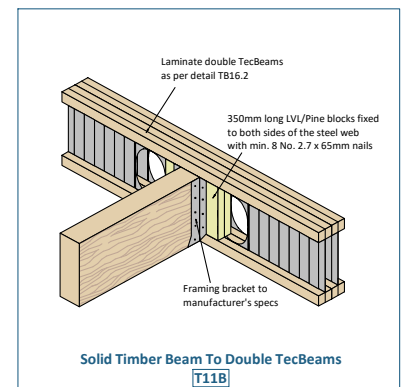
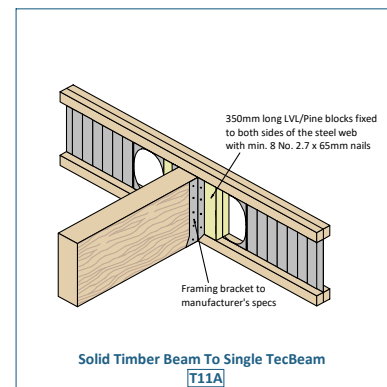

## Web Stiffeners (Over Support & Under PL/LBW)

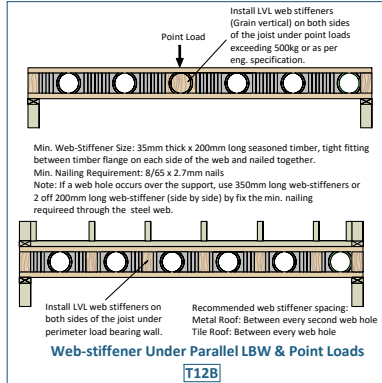
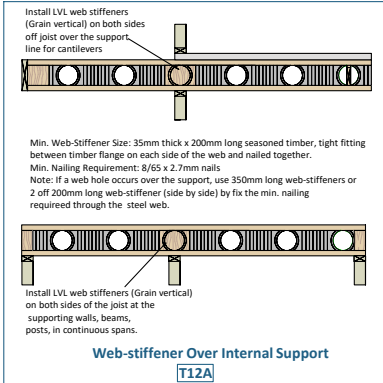

## Multiple TecBeams Lamination

