

# SmartLam GL19C

(Pre-cambered)

## Design Guide

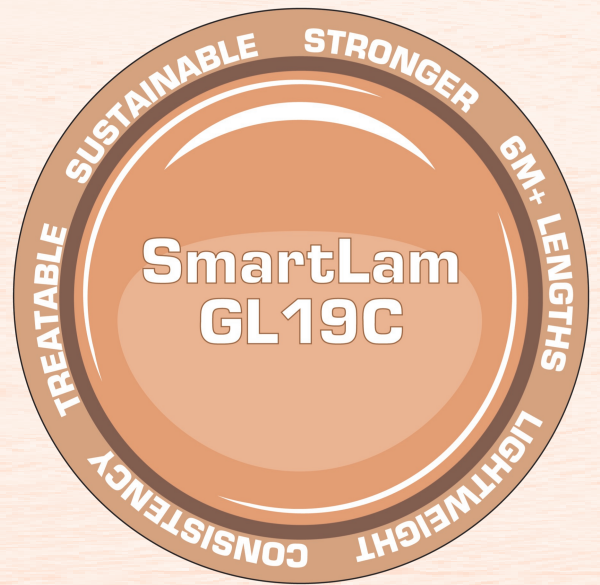





## Table of contents

Introduction	2
Ordering SmartLam GL19C	3
Installation	
- Preparatory work	2
- Deflection	2
- Verticality	2
- Holes for services	2
- Notches	3
- Birdsmouthing	4
- Eaves overhang	4
- Steel post and timber fixing	4
Multiple SmartLam GL19C section beams	
- Type 17 screw	5
- bolts	5
Durability and weather exposed application	6
Protection systems	
- During construction	7
- Covered alfresco beams	7
- Painted SmartLam GL19C	7
- Design and construction detailing	7
Fire rating (resistance)	8
Checking of SmartLam GL19C	8
Designing with SmartLam GL19C	
- Product specification	9
- Limit state design characteristic	9
- Strength reduction factors	9
- Duration of load	9
- Partial seasoning factor	9
- Length and position of bearing	9
- Load sharing	9
- Stability	9
- Temperature	9
Beam section properties	11
Design/Effective span	10
Storage and handling	11
List of table and charts	11
Span tables	12-32

### SmartFrame Product Warranty\*

Tilling Timber warrants that its SmartFrame Engineered Wood products will be free from manufacturing defects in workmanship and material.

In addition, provided the product is correctly installed and used, Tilling Timber warrants the adequacy of its design for the normal and expected life of the structure.

This warranty is backed by the full resources of Tilling Timber and by underwritten product liability insurance.

Tilling Timber Pty Ltd  
31-45 Orchard Street  
Kilsyth Vic 3137

Ph: +61 (0)3 9725 0222 Fax: +61 (0)3 9725 6569  
Email: techsupport@tilling.com.au

## Scope of this publication

This Design Guide and Load Tables assist in the selection of SmartLam GL19C for some of the common structural arrangements met in domestic construction.

Other than the limited examples uniquely associated with GLT shown, methods of developing lateral restraint and providing adequate support, adequate anchorage against wind uplift, and overall structural stability are outside the scope of this publication.

Information on the above matters can be obtained from AS 1684 Residential timber-framed construction or from a structural engineer experienced in timber construction.

Tilling Timber Pty Ltd have structural engineers within the SmartFrame Design Centre who can be contacted for advice on matters concerning the use of its SmartFrame engineered timber products in timber construction via the technical support Helpline on 1300 668 690 or e-mail at techsupport@tilling.com.au

### Substitution of other products

All load tables in this document are designed using the unique characteristic properties of SmartLam GL19C manufactured to AS/NZS 1328 by quality producers 3<sup>rd</sup> party audited by the GLTAA, exclusively distributed by Tilling Timber Pty Ltd.

### Copyright

Copyright of this publication remains the property of Tilling Timber Pty Ltd, and reproduction of the whole or part of this publication without written permission from Tilling Timber Pty Ltd is prohibited.

### Certification

As a professional engineer, qualified and experienced in timber engineering, I certify that the use of the SmartLam GL19C members as shown in these tables, and installed in accordance with the provisions of this Design Guide, complies to the Building Code of Australia. These Span Tables have been prepared in accordance with standard engineering principles, the relevant test reports and Australian standards, ie:

- AS 1720.3 Timber structures Part 3: Design criteria for timber framed residential buildings
- AS 1720.1 Timber structures - design methods
- AS 4055 Wnd loads for houses
- AS/NZS 4063 Characterisation of structural timber
- AS/NZS 1328 Glue laminated structural timber - performance requirements and minimum production requirements.

*Craig Kay*

CRAIG KAY RPEng, BDC0730, PE0001869,  
RPEQ 5100, CC5635C, NER  
National Product Engineer



The information contained in this product brochure is current as at December 2021 and is based on data available to Tilling Timber Pty Ltd at the time of going to print. Tilling Timber Pty Ltd has used its reasonable endeavours to ensure the accuracy and reliability of the information contained in this document and, to the extent permitted by law, will not be liable for any inaccuracies, omissions or errors in this information nor for any actions taken in reliance on this information. Tilling Timber Pty Ltd reserves the right to change the information contained in this document without prior notice. It is important that you call the technical support customer Helpline on 1300 668 690 to confirm that you have the most up to date information available.

# SmartLam® GL19C

## Introduction

SmartLam GL19C beams are manufactured for Tilling Timber by 3<sup>rd</sup> party audited quality GLT manufacturers to AS/NZS 1328. SmartLam GL19C GLT beams are engineered timber products with high strength, dimensional stability, great load carrying capacity and superior fire resistance.

All timber used for laminating is carefully selected from production and graded according to specification. After trimming to the desired size, all stock is kiln dried to 12% average moisture content, to ensure efficient bonding in the gluing operations. The laminations are finger jointed by machine, with glue being cured by cold press system and controlled temperature.

## Benefits of SmartLam GL19C

**Cost Effectiveness** - SmartLam GL19C beams high strength to weight ratio allows you to design for maximum loads over large spans with the smallest possible end sections.

**Product Quality** - All SmartLam GL19C beams are manufactured in accordance with AS/NZS 1328 Glue Laminated Structural Timber and the Glued Laminated Timber Association (GLTAA) Industry standard GLTAA-4-91. .

**Fire safety** - Extensive fire test data shows that large end section timber performs well in fire situations due to the formation of a protective layer of char which usually occurs at a temperature around 250° C. This charred area inhibits the effects of the fire on the inner portion of the timber component, hence it maintains structural load support for measurable periods of time as the fire progresses.

Conversely, steel loses its strength rapidly as the temperature is raised. At about 550°C, it has lost about 50% of its original bending strength, and by 750°C it has lost 90%. Timber does not lose strength in the same way, with the loss of section size through charring the major reason for any strength reduction.

**Fast easy erection** - Timber is a user friendly building material, requiring no special tools other than those a normal builder would use, and with SmartLam GL19C beams, installation is fast, easy and efficient.

**Environmental responsibility** - SmartLam GL19C beams are made from timber from sustainable managed forests under the FSC Certification scheme SGSHK-COC-450019, License Code FSC-C129865.

**Low maintenance** - In most applications, SmartLam GL19C beams will require little or no maintenance other than that which you would ordinarily carry out to any structural material.

**Natural beauty** - The natural beauty of timber is desired and highly appropriate in many architectural applications. Appearance Grade B SmartLam GL19C beams allow you to build timber's natural warmth and beauty into your designs.

## Ordering SmartLam GL19C

Stock SmartLam GL19C GLT has a 600 m radius camber and in Appearance Grade B

AS/NZS 1328.2 defines 3 appearance grades:

- Appearance Grade A - Sanded with any voids filled - intended for applications where appearance is important and clear or painted finishes are used
- Appearance Grade B - intended for applications where appearance is important but where a planed finish is acceptable

- Appearance Grade C - intended for applications where appearance is unimportant

## SmartLam GL19C B grade



## Protection and handling

Care should be taken during delivery to avoid marking and to avoid damage. Unloading of trucks should be done by hand or with a crane, do not drop or dump members. During unloading with lifting equipment, use fabric or plastic belts or other slings which will not mark the wood. If chains or cables are used, provide protective blocking or padding. Guard against soiling, dirt, footprints, abrasions, or injury to sharp edges or corners.

## Installation

### Preparatory work

Carefully unload and handle the laminated members at job site to prevent surface marking and damage. If laminated timber is to be stored before erection, place it on blocks well off the ground with individual members separated by strips so that air may circulate around all four sides. The top and the sides of storage pile shall be covered with moisture resistant covering. Wrapping shall be left intact, but individual wrappings shall be slit or punctured on the lower side to permit the drainage of water that may have accumulated. Before erection, the assembly should be checked for any damage from water or handling, prescribed camber, and accuracy of anchorage connections.

Laminated beams can be nailed into place in the same way as solid timber beams. Alternatively, a range of plates are available for end fixing. For larger beams, special purpose, engineer designed end fixing should be used.

### Deflection

All structural members deflect downwards when dead loads are applied, and therefore it is important to allow for this deflection structurally and/or aesthetically in the selection of the beam sizes. The "Deflection Limits" table on page 10 details deflection limits for various applications.

### Verticality

SmartLam GL19C members must not be installed out of plumb more than height/500.

### Holes for services

Horizontal Holes - Like notches, holes in a GLT beam remove wood fibre, reduce the net area of the beam at the hole location, and introduce stress concentrations. For this reason, horizontal holes in GLT beams are limited in size and location to maintain the structural integrity of the beam. The diagram on the next page shows the zones of a uniformly loaded, simply supported beam where field drilling of holes may be considered.

Field drilled horizontal holes should be for access only and should not be used as attachment points for brackets or other load bearing hardware unless specifically designed as such by the Engineer/Designer.

Regardless of the hole location, the net section of the beam remaining should be checked for flexure and horizontal shear.

Vertical holes - As a rule of thumb, vertical holes drilled through the depth of a GLT beam cause a reduction in capacity at that location directly proportional to the ratio of 1½ times the diameter of





## Installation (cont'd)

stresses for those laminations remaining at the notch location.

When it becomes necessary to cut a small notch in the top of a glued laminated timber (in the compression zone) to provide passage for small diameter pipe or conduit, this cut should be made in areas of the beam stressed to less than 50% of the design bending stress. The net section in these areas should be checked for shear and bending stresses to ensure adequate performance.

All field notches should be accurately cut. Avoid over-cutting at the root of the notch. Drilling a pilot hole in the member at the interior or corner location of a notch as a stop point for the saw blade provides both a rounded corner and minimizes over-cutting at the corner.

Stress concentrations due to notches can be reduced by using a gradually tapered notch configuration in lieu of a square-cornered notch. Rounding the square corner of a notch with a radius of approximately 12 mm is also recommended to reduce stress concentrations in these areas.

For square-cornered notches occurring at the ends of beams on the tension side, the designer may consider the use of reinforcement, such as full-threaded lag screws, to resist the tendency to split at the notch (See diagram below). A number of design methodologies exist for sizing such screws.

The design methodology selected and subsequent fabrication details are the responsibility of the project designer/engineer. If lag screws are used, lead holes shall be predrilled in accordance with accepted practice. This procedure can also be used as a field remedy to minimize further propagation of an existing crack.

Further information about the use of screw reinforcement can be obtained by contacting the technical support Helpline on 1300 668 690 or e-mail at [techsupport@tilling.com](mailto:techsupport@tilling.com).

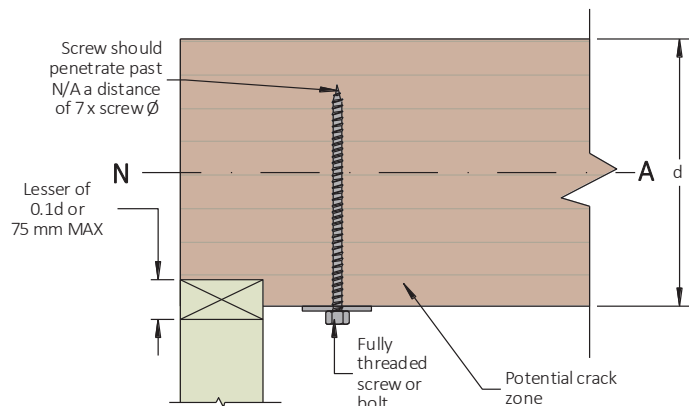

### Birdsmouthing

Figure 3 - Birds mouting details for SmartLam GL19C

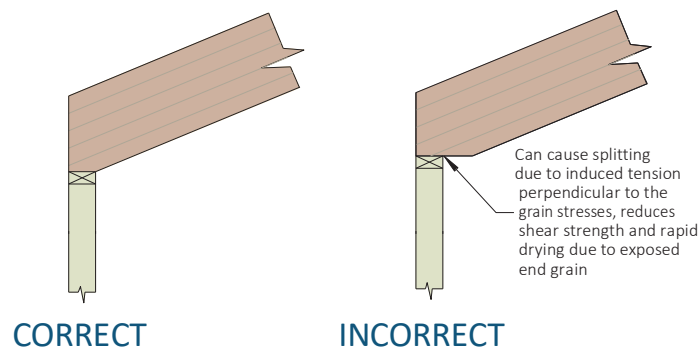

### Eaves overhang

Figure 4 - Eaves overhang details for SmartLam GL19C

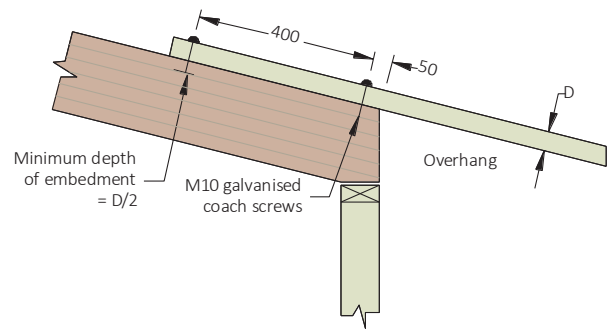

Note: Refer to AS 1684 Residential timber-framed construction code for overhang member size.

### Allowable Eaves overhangs

#### 1. Non Cyclonic Areas

Beams for flat or similar roofs - Not Birds mouthed: Eaves overhang shall not exceed 40% of the actual beam span.

Beams with conventional pitched roofs - Birds mouthed to one third their depth:

- I. Sheet roof - 20% of actual beam span
- II. Tiled roof - 30% of actual beam span

#### 2. Cyclonic Areas

Recommendations as per above, but reduced as follows:

Non Birds mouthed:

- 25% of actual beam span

Birdsmouthed:

- Sheet roof - 10% of actual beam span
- Tiled roof - 20% of actual beam span

### Steel and Timber fixing to SmartLam GL19C

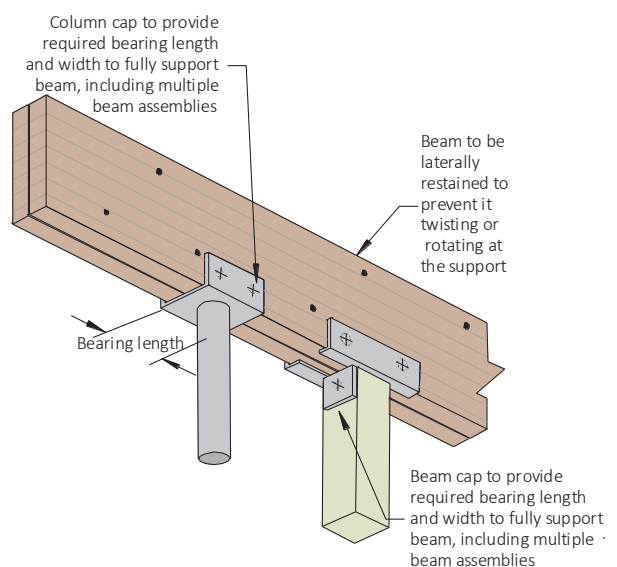

# Installation (cont'd)

## Multiple SmartLam GL19C section beams

Vertical laminations may be achieved by adopting the principle described in clause 2.3 of AS 1684, however, due to the thickness of SmartLam GL19C, nails are NOT suitable for combining SmartLam GL19C beams.

Experience with GLT beams indicates that multiple member laminations individual components may cup as a result of the ingress of moisture between laminates during construction. The suggested method of vertical lamination shown below provides a greater level of fixity between individual components, and combined with

the use of a temporary waterproof membrane and an elastomeric adhesive prevents moisture penetration between the laminates.

Maximum floor load width tables for multiple member laminations of SmartLam GL19C:

1. Type 17 screw lamination

2. Bolt lamination

are shown below.

### 1. Type 17 screws

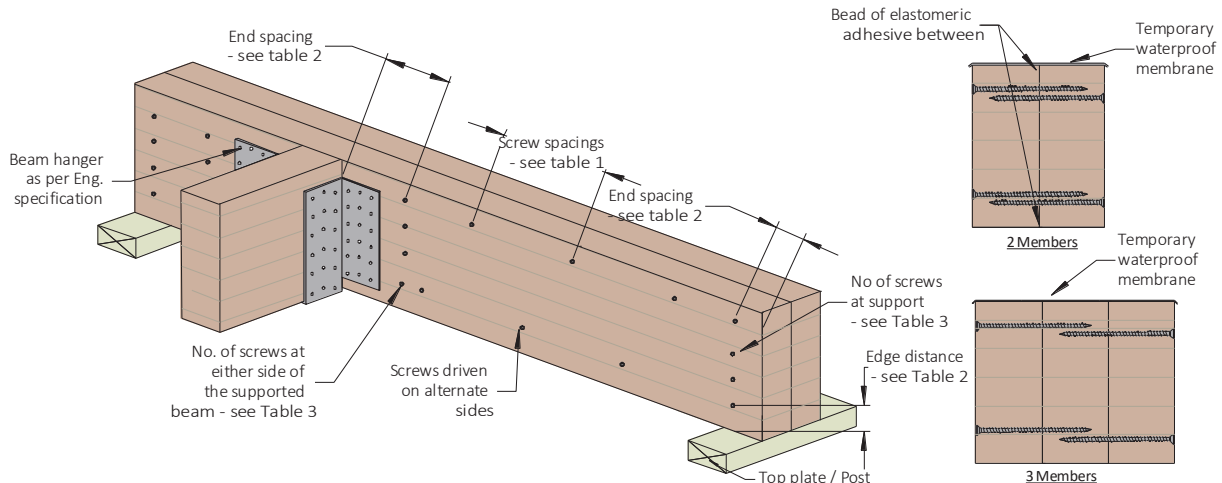

Table 1

Side (non-symmetrically) and top loaded beam				
Section width	Type 17 screw size	No of screw rows (both sides)	Screw spacing (mm)	Max. floor joist span supported by outer member (mm)**
2/75 & 3/75	14g x 100	2 or 3*	300	7700
2/60 & 3/60	14g x 125	2 or 3*	300	6000
* for beam depths $\geq 300$ mm, use 3 rows of screws				
** Floor loads $G = 1.25$ kPa, $Q = 2.0$ kPa				

Table 2

Type 17 screw size	Min. edge distance (mm)	Min. end distance (mm)	Min. distance between screws (across the grain) (mm)
14g	40	70	30

Table 3

Beam depth (mm)	Min. number of screws required	
	At support	At either side of supported beam
90 – 240	3	3
> 240	4	4

### 2. Bolts

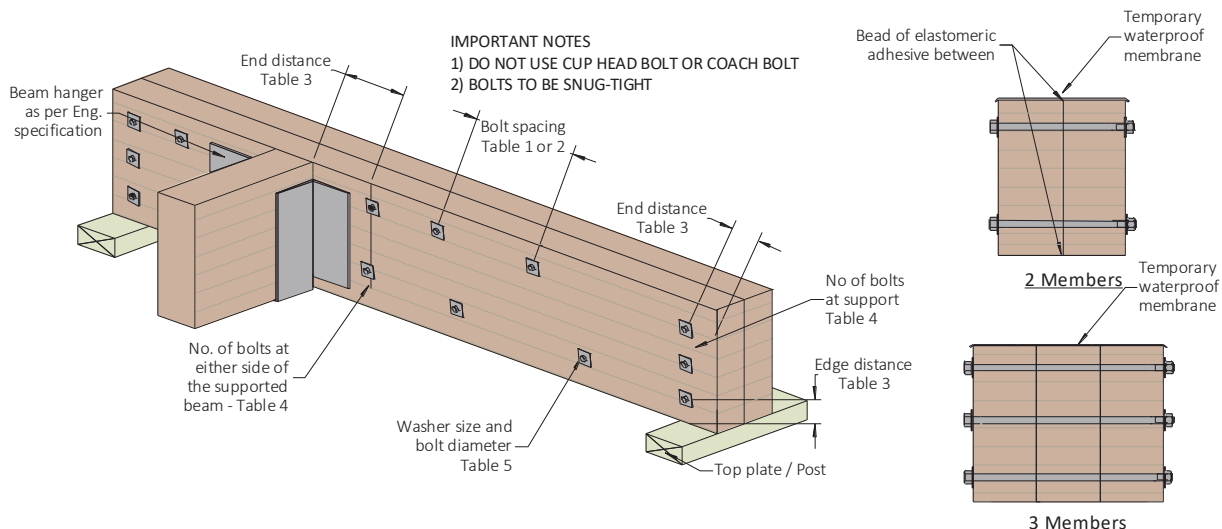

**IMPORTANT NOTES**  
 1) DO NOT USE CUP HEAD BOLT OR COACH BOLT  
 2) BOLTS TO BE SNUG-TIGHT

## Installation (cont'd)

### 2. Bolts (Cont'd)

Table 1

Top (symmetrically) loaded beam - M12 Hex head bolt	
Beam depth ≤ 300 mm	Beam depth > 300 mm
2 rows of bolts at 600 mm ctrs	3 rows of bolts at 600 mm ctrs

Table 2

Side (Non symmetrically) loaded beam - M12 Hex head bolt		
Maximum floor joist span supported by the beam mm*		
2 rows at 600 mm ctrs	2 rows at 300 mm ctrs	3 rows at 600 mm ctrs
11,00 mm	>12	>12

\* based upon floor loads of G: 1.25 kPa Q: 2.0 kPa

Table 3

Bolt size	Min. edge distance	Min. end distance	Min. distance between bolts (across grain)
M12 Hex head	60 mm	60 mm	60 mm

Table 4

Beam depth (mm)	Min. number of bolts required	
	At support	At either side of supported beam
90–150	1	1
160–240	2	2
> 240	3	3

Table 5

Bolt diameter (mm)	Washer dimensions		
	Thick-ness (mm)	Min. diameter of round washers (mm)	Min. side length of square washers (mm)
M12	3	55	50

## SmartLam durability and weather exposure

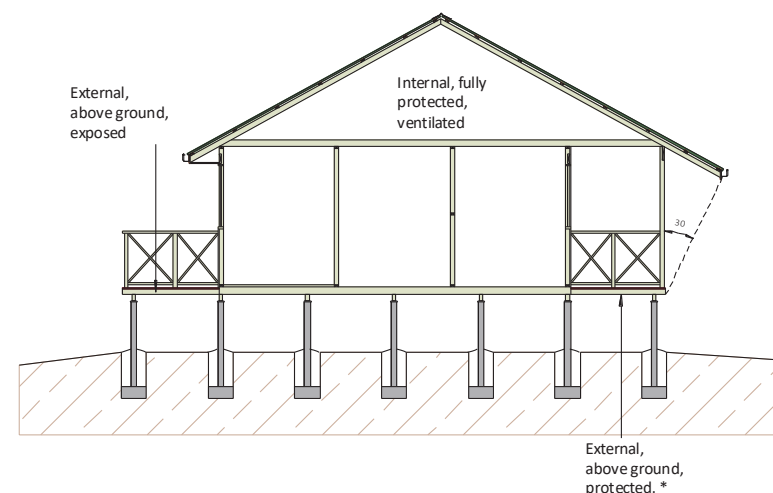

### AS 1684 definitions of exposure zones within a structure

\* External timbers are regarded as protected in AS 1684 if they are covered by a roof projection (or similar) at 30° to the vertical and they are well detailed and maintained (painted and kept well ventilated).

SmartLam GL19C's are manufactured from kiln dried timber (MC less than 15%), and therefore need to be protected from moisture cycling that can occur from:

- Exposure to direct sun and rain (including during construction)
- Contact or close exposure with moisture laden porous material (e.g. Concrete blocks)
- Exposure to extreme environments such as dry heating systems (e.g. slow combustion wood heaters), air conditioning, large north or west facing windows or moisture laden environments such as pool enclosures.

### SmartLam GL19C protection methods

#### During Construction (pre-water proof roof)

SmartLam GL19C's are supplied WITHOUT any short term construction sealer. However if SmartLam GL19C is expected to be exposed for an extended period or become wet, it is recommended that the beam be sealed with a construction sealer that is com-

patible with the final paint or varnish finish, or wrapped in plastic to provide protection (plastic must allow for drainage and air circulation to breath).

Examples:

- If the SmartLam GL19C is installed inside a building without direct exposure to air-conditioning such as in wall cavity, NO protection to the beam is required.
- If the SmartLam GL19C is installed inside a building with direct exposure to air conditioning or dry heat then a sealer is required.
- If the SmartLam GL19C is under the eaves and protected from direct rain and sun, it is recommended that the construction sealer be lightly sanded and a finish coat of compatible premium quality paint be applied. (In accordance with paint manufacturer's specifications).
- It is NOT recommended that ANY SmartLam GL 19 be used in **external, above ground, exposed** applications.



# SmartLam durability and weather exposure (Cont'd)

## Covered alfresco beams

Alfresco beams constructed to comply with the diagram below are technically classified in AS 1684 as **External, above-ground, protected**. (see previous page)

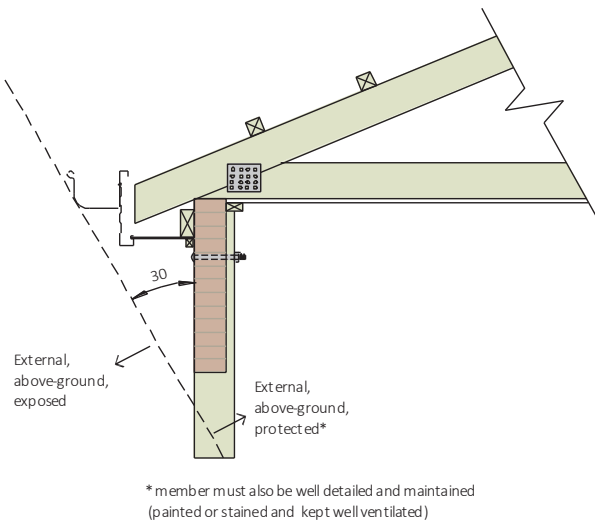

SmartLam GL's used in protected exterior applications must be:

- I. Correctly detailed by fully enclosing member with a mechanical barrier such a cement sheet if it is likely to get wet or experiences direct sun
- II. Mechanical barrier correctly painted with a premium quality protective finish (e.g. light coloured pigmented external paint system) to prevent moisture infiltration.

It is important that an inspection and maintenance programme, based on exposure level and the paint manufacturer's recommendations be prepared.

## Painting SmartLam GL19C

### General

To provide the longest service life of the SmartLam GL19C, it is recommended the SmartLam GL19C's are painted with an exterior paint with a Light Reflectance Value (LRV) greater than 30%. Heat reduction exterior paints should be used where the desired colour is dark or has a LRV of less than 30%. The heat reflective paints colours should be limited to a Total Solar Reflectance (TSR) value greater than 29%.

Any paint or stain must be recommended by the manufacturer as being suitable for the proposed application and must be applied in a manner in strict compliance to the manufacturer's recommendations.

1. The wood must be dry and clean prior to applying any finish coating. If initial cleaning of the treated wood is needed, it is recommended that the project be cleaned with a deck cleaning product and allow to fully dry
2. At this time, a clear water repellent can be added to the project. If applied, allow 8 weeks prior to the application of a semi-transparent stain or paint

Users must always conduct their own tests on coatings in inconspicuous areas of the project to determine acceptability of colour, adhesion and appearance.

## Design & Construction detailing tips

- i. The use of building overhangs and other structures

which protect the beams from excessive moisture movement and sun exposure.

- ii. Shielding of the beam from free moisture or direct sun. The use of metal, fibro or plastic shields on the exposed faces or ends of beams is highly recommended to help maintain the beam in an unstressed dry condition.
- iii. All beams should be provided with adequate ventilation so that moisture content within beams will not exceed 15% and moisture gradients across the beam will not occur.
- iv. The use of arrised or round edges on beams to reduce the likelihood of coating failures on sharp edges.
- v. The use of drip edges or other devices which provide a path for free moisture flow away from the timber beam. Refer to detail below opposite.
- vi. Joint detailing should, wherever possible, comply with the following:

- Keep horizontal contact areas to a minimum, In favour of self draining vertical surfaces.
- Ventilate joint surfaces by using spacers, wherever possible.
- Always use compatible fasteners which have adequate corrosion protection and do not cause splitting during installation e.g. Hot dipped galvanic coatings or stainless steel.
- Ensure any moisture entering a joint is not trapped but can adequately drain away from the joint.

- vii. Allow for thermal expansion/contraction in the joint design.

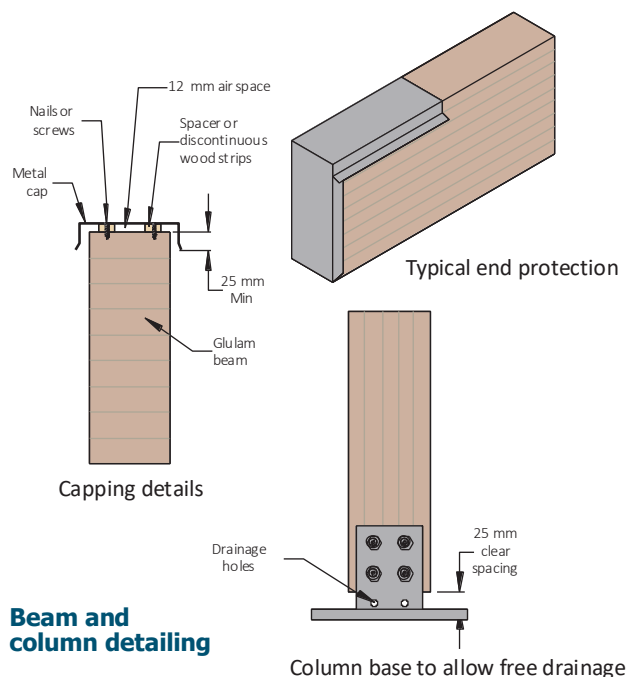

## Beam and column detailing

# SmartLam GL19C and fire

## Fire resistance

The Fire Resistance Level (FRL) is the performance criteria for fire resistance, i.e. the grading periods (in minutes) for the following criteria as specified in the BCA:

- a. Structural adequacy: (the duration for which the elements can carry its designated load)
  - b. Integrity: (the duration for which the element can maintain its integrity to prevent the spread of fire to/ from the compartment)
- and
- c. Insulation: (the duration for which the element is insulating the adjacent space from excessive temperature rise)

and is expressed in that order e.g. 30/30/30. The method for determining the structural component of the Fire Resistance Period for timber (including LVL and GLT) is described in AS /NZS

## Checking in SmartLam GL 19C

One of the advantages of glued laminated timber construction is that while seasoning checks may occur for the same reasons that they do in sawn members, checking in glued laminated timber will generally occur to a much lesser degree because of careful control of the moisture content of timber used for laminating. Checks in wood are separations along the fibres normally occurring across the rings of annual growth resulting from stresses developed during changes in moisture content. Checks in glued laminate timber may appear as openings parallel to the grain on the sides of members.

As wood loses moisture to the surrounding atmosphere, the outer fibres of the member lose moisture at a more rapid rate than do the inner fibres. As outer fibres try to shrink, they are restrained by the inner portion of the member that has higher moisture content. The more rapid the rate of drying, the greater will be the differential in shrinkage between the outer and inner fibres resulting in higher shrinkage stresses.

These resultant stresses perpendicular to the grain of the wood can cause characteristic wood seasoning checks. The influence of checks on the structural performance of glued laminated timber members is generally minor. Checking can be minimized by careful installation practices that avoid prolonged exposure of the members during construction.

### Identification of checking

Checks occur as transverse separations or openings that are nearly parallel to the grain direction in glued laminated timber and generally follow the grain direction around knots and along sloping grain. Differences in the shrinkage rate of individual laminations used in glued laminated timber tend to concentrate shrinkage stresses at or near glue lines, resulting in checks.

Checks are often confused with delamination that occurs when the glue bond is not adequate. The presence of wood fibre separation in these openings is the key distinguishing characteristic of seasoning checks. Openings due to inadequate adhesive bonding may appear as smooth wood surface separations, possibly darkened by the adhesive film, or as glossy surface areas of adhesive with an absence of torn wood fibres.

Checking often occurs along the first glue line adjacent to the out-

1720.4 - 2019 Timber Structures Part 4: Fire resistance of timber elements.

$$c = 0.4 + \left( \frac{280}{\delta} \right)^2$$

where:

c = notional charring rate, in mm per minute

d = timber density of SmartLam GL19 - ~ 900 kg/m<sup>3</sup>

The effective depth of charring ( $d_c$ ) after a period of time (t) shall be calculated in accordance with Clause 2.6.1 for surfaces exposed to fire and in accordance with Clause 2.6.2 for surfaces behind fire - resistant protective insulation.

Further information about using SmartFrame product in fire rated applications can be obtained by contacting the Techsupport Helpline on 1300 668 690 or email techsupport@tilling.com.au.

er lamination that may dry more rapidly because a larger surface area of that lamination is exposed to the air. This condition is sometimes aggravated when the outer lamination tends to cup, creating tension perpendicular to grain stresses along or near the first glue line.

### Significance of checking

In general, checks have little effect on the strength of glued laminated members. Glued laminated members are made from laminations that are thin enough to season readily in kiln drying schedules without developing checks. Checks usually appear on the wide faces of the timber and do not materially affect the shear strength of the laminations. In cases where members are designed for loading parallel to the wide face of the laminations, checks may affect the shear strength of the beam their effect may be evaluated in the same manner as for sawn timber. Seasoning checks in bending members affect only the horizontal shear capacity.

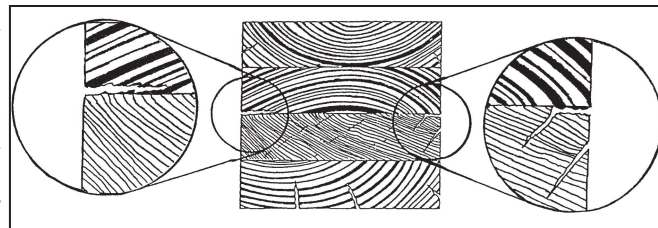

In establishing allowable horizontal shear values, normal checking due to seasoning has been considered.

Checks are usually not of structural importance unless they are significant in depth, occur in the mid-height of the member near the supports, and the design of the member is governed

by shear. If these conditions exist, the reduction in shear strength is directly proportional to the ratio of the depth of checks to the width of the bending member. Checks in columns are not of structural importance unless the check develops into a split, thereby increasing the l/d ratio of the column.

### Additional information

While checking is not considered to be of structural significance, the reason for the checking and the means by which further checking may be minimized should be determined.

If there is concern regarding structural adequacy, advice can be obtained from engineers from the SmartFrame Design Centre or a structural engineer experienced and qualified in glued laminated timber technology should evaluate the significance of the checking.

The SmartFrame Technical Note - "Evaluation of Checking in Glued Laminated Timber (GLT)" gives detailed analysis of the modification to structural capacity as a result of severe checking.

# Designing with SmartLam GL19C

The design information contained within this Design Guide is for the properties of SmartLam GL19C only. Other manufacturers' LVL may have different properties and therefore cannot be designed using this information.

## 1. Product Specification

<b>Lamella:</b>	Thickness:	25-45 mm
	Species:	Keruing
	Strength Group	SD3
	Joints:	Finger joint
<b>Dimensional tolerances:</b>	Length:	± 10 mm
	Depth:	≤ 100 mm ± 1 mm ≥ 100 ≤ 302 mm ± 3 mm ≥ 301 ≤ 600 mm ± 4 mm ≥ 601 ± 6 mm
	Thickness:	-0, +4 mm at 12% moisture content
<b>Adhesive:</b>	Complies with AS/NZS 4364:2010	
<b>Treatment options:</b>	Seek current treatment options before order ordering	

## 2. Limit State Design Characteristic Properties

Timber Strength Properties: <sup>(1)</sup>		
Bending	$f_b$	45 MPa
Tension Parallel to grain	$f_t$	25 MPa
Tension Perpendicular to grain	$f_{tp}$	0.6 MPa
Compression Parallel to grain	$f_c$	45 MPa
Compression Perpendicular to grain - Edge	$f_p$	17 MPa
Shear	$f_s$	5.0 MPa
Average Elastic Modulus	E	19,000 MPa
Average Modulus of Rigidity	G	1267 MPa
Average Density		900 kg/m <sup>3</sup>
Moisture Content		12-15%

(1) Dry conditions

## 3. Strength reduction factor

The strength reduction factor for calculating the design capacities of structural members shall be taken from the table below, referenced from AS 1720.1-2010

Application of SmartLam GL19C as a structural member		
Category 1	Category 2	Category 3
Structural members for houses for which failure would be unlikely to affect an area greater than 25 m <sup>2</sup> ; OR secondary members in structures other than houses	Primary structural members in structures other than houses; OR elements in houses for which failure would be likely to affect an area* greater than 25 m <sup>2</sup>	Primary structural members in structures intended to fulfil essential services or post disaster function
<b>Strength reduction factor <math>\phi</math> *</b>		
0.95	0.85	0.75

\* AS 1720.1:2010 Table 2.1

## 4. Duration of load

The duration of load factor  $k_1$  for strength is defined within clause

Duration	Service class / exposure classification		
	1, 2	3	Severe/ Adverse
Short term ≤ 1 Day	1.0	1.0	1.0
Long term > 12 months	1.5	2.0	3.0*

Notes:

- \* Any beams to be used in service class 3 are outside the scope of these span tables, therefore specialist design advice should be sought from an engineer.
- In general, the size of this beam can conservatively be obtained by the following method:
  - Obtain the beam size for service class 1 & 2
  - Obtain the  $EI_{xx}$  from the "Section Properties" table for this beam
  - Obtain from the "Section Properties" table a beam size with an  $EI_{xx} \Rightarrow 2/1.5 \times EI_{xx}$  of the original beam
  - Follow the recommendations for Smartlam durability and weather exposure on page 6
- Service Classes 1,2 & 3 are defined in AS 1328

## 5. Partial seasoning factor

SmartLam GL19C is a seasoned timber product, generally  $k_4$  equals 1. Where the GLT is subjected to conditions in which the average moisture content for a 12 month period is expected to exceed 15%, the characteristic capacity shall be decreased. The value of  $k_4$  shall be the greater of:

$$k_4 = 1 - 0.3 \frac{EMC - 15}{10};$$

- $k_4 = 0.7$

Where EMC is the highest value of the annual moisture content (percent) that the timber will attain in service.

## 6. Length and position of bearing

The  $k_7$  bearing factor is defined in clause 2.4.4 of AS 1720.1

## 7. Load sharing

Because of the reduced variability of strength values of GLT compared to solid timber, the load sharing factor  $k_9 = 1.0$  as defined in clause 7.4.3 of AS 1720.1

## 8. Stability

The stability factor  $k_{12}$  is defined within section 7 of AS 1720.1 beams. The methods for calculating  $k_{12}$  for solid wood in section 3 of AS 1720.1 shall generally apply except that the material constant ( $\rho_b$  or  $\rho_c$ ) for beams and column shall be as given in Tables 7.2(A) and 7.2(B)

## 9. Temperature

For covered timber structures under ambient conditions, no modification for strength need be made for the effect of temperature (i.e.,  $k_6$  equals 1.0) except that where seasoned timber is used in structures erected in coastal regions of Queensland north of latitude 25°S, and all other regions of Australia north of latitude 16°S, the strength shall be modified by a factor  $k_6$  of 0.9.

# SmartLam GL19C Beam Properties

Nominal Size DxB mm	Beam Mass kg/m	Nominal section area 10 <sup>3</sup> mm <sup>2</sup>	Major axis			Minor axis	
			Zxx 10 <sup>3</sup> mm <sup>2</sup>	Ixx 10 <sup>6</sup> mm <sup>4</sup>	EIxx 10 <sup>9</sup> Nmm <sup>2</sup>	Zyy 10 <sup>3</sup> mm <sup>2</sup>	Iyy 10 <sup>6</sup> mm <sup>4</sup>
130 x 60	7.0	7.8	169	11	209	78.0	2.3
165 x 60	8.9	9.9	272	22	427	99.0	3.0
195 x 60	10.5	11.7	380	37	704	117.0	3.5
230 x 60	12.4	13.8	529	61	1156	138.0	4.1
260 x 60	14.0	15.6	676	88	1670	156.0	4.7
295 x 60	15.9	17.7	870	128	2439	177.0	5.3
330 x 60	17.8	19.8	1089	180	3414	198.0	5.9
360 x 60	19.4	21.6	1296	233	4432	216.0	6.5
165 x 75	11.1	12.4	340	28	533	154.7	5.8
195 x 75	13.2	14.6	475	46	881	182.8	6.9
230 x 75	15.5	17.3	661	76	1445	215.6	8.1
260 x 75	17.6	19.5	845	110	2087	243.8	9
295 x 75	19.9	22.1	1088	160	3049	276.6	10
330 x 75	22.3	24.8	1361	225	4268	309.4	12
360 x 75	24.3	27.0	1620	292	5540	337.5	13

## SmartLam GL19C Design / Effective span

Normal structural analysis uses the centreline representation of the member. The term “span” can be defined in a number of ways and these are defined as follows:

**Clear span.** This is the distance between the faces of any support. It is generally the one easiest to measure and read from the drawings

**Nominal span/centre-line span.** This is the distance between the centre of the supports. This span is used to determine bending moments and deflections for continuous spanning members

**Design span/Effective span.** This is the span used for single span members to determine the bending moment, the slenderness of bending members and the deflections. In NZS 3603 this is the dimension referred to as “L”, and is defined below.

Design span/Effective span is the distance between -

- The centre of the bearing at each end of a beam where the bearing lengths have NOT been conservatively sized
- The centre of notional bearing that have been sized appropriately, where the size of the bearing IS conservative.

Diagram (a) shows beam where bearings have been designed appropriately. The effective span is taken as the distance between the centre of each bearing area

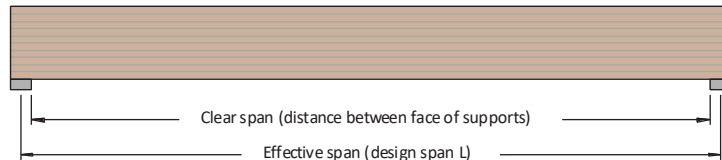
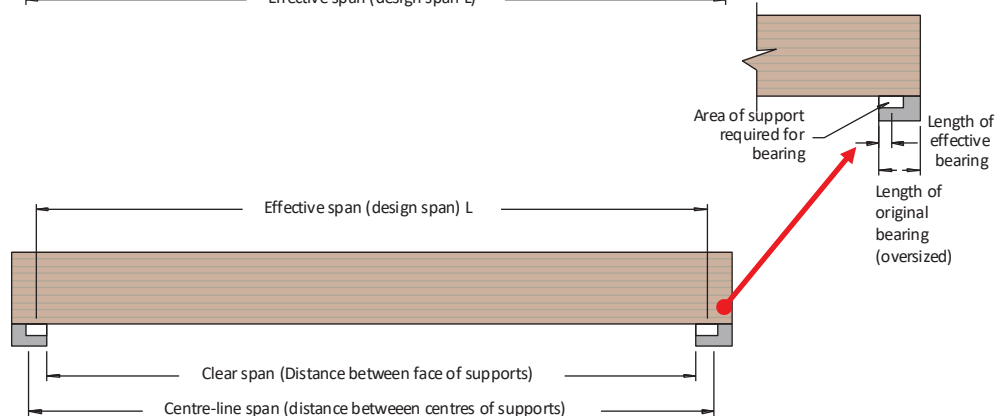

Diagram (b) shows beam where bearings at each end have been oversized. (This is frequently the case for beams that bear onto brickwork or concrete walls where the thickness of the wall is in excess of the area required to give the beam bearing capacity). To find the correct effective span:

1. Calculate the minimum bearing required to carry the loads satisfactorily
2. Add minimum bearing length to “clear span” distance



span difference	effective span	resultant span description
10% Max	main span	continuous
10 – 30%	1.1 x main span	continuous
Above 30% difference	main span	single

$$\text{span difference} = \frac{(\text{major span} - \text{minor span}) \times 100}{(\text{major span} + \text{minor span})}$$

The span to use in the case of unequal continuous spans is the "resultant span description" as shown in the table above. (Note: It is recommended for the most accurate designs, that the SmartFrame software be used.)



## Storage and handling of SmartLam GL 19

1. Store SmartLam GL19C's flat on a hard, dry surface
2. If surface isn't paved, the ground should be covered with a polythene film
3. Keep covered with waterproof material that allows bundles to "breathe"
4. Use bearers (bolsters) between the ground and the first bundle (4 metre max spacing)
5. Use 100 x 50 timber flat between bundles at same spacing as bolsters
6. Take great care to rewrap remaining material after opening bundles
7. Timber "grows" in thickness and depth when allowed to get wet....KEEP DRY!
8. Timber products with high MC has short term reduction in Characteristic Strengths .... KEEP DRY!
9. Under NO circumstances is stored SmartLam GL19C to be in contact with the ground.

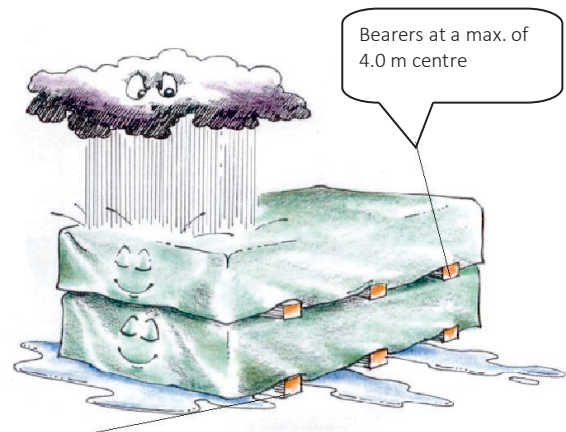

Use bearers to keep stacked material away from damp surfaces. Align bearer vertically

## Span tables for SmartLam GL 19

### LISTS OR TABLES AND CHARTS

Floor bearers - floor loads only	12
Bearers - wall and roof loads - sheet and tiled roof	13
Single/upper storey lintels	15
Lower storey lintels supporting load bearing walls and floors	17
Rafters/Roof beam - ceiling attached	18
Rafters/Roof beam -no ceiling attached	21
Ridge or intermediate beam	24
Verandah beam	
- single span wind classification N1-N3	26
- continuous span wind classification N1-N3	27
Verandah beam	
- single span wind classification C1-C3	29
- continuous span wind classification C1-C3	30
Hip or valley rafter	32

# Floor bearers supporting floor loads only

Floor mass - 40 kg/m<sup>2</sup>

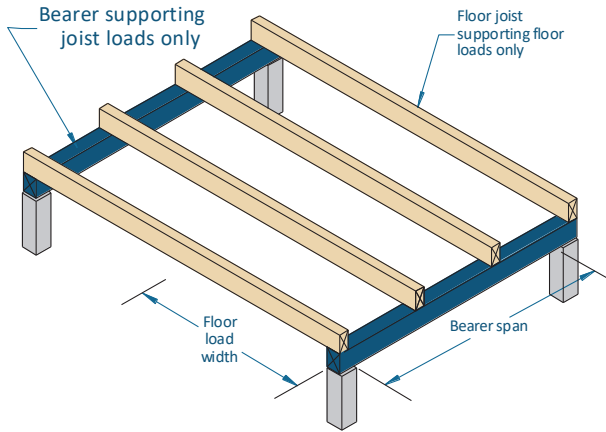

### EXAMPLE:

single span bearer = 4000 mm  
 floor load width = 6000 mm

Enter single span table at 6000 mm in floor load width column, read down to a span equal to or greater than 4000 mm

### ADOPT:

SmartLam GL19C - 330x60 mm

Loadings: Permanent - self weight + 40 kg/m<sup>2</sup> + 0.6 kPa of the live load, live load - 1.5 kPa or floor point load of 1.8 kN

Floor load width (mm)	1200	1800	2400	3000	3600	4200	4800	5400	6000	6600
	<b>Maximum recommended bearer span (mm)</b>									
<b>Member Size DxB (mm)</b>	<b>Single span</b>									
130x60	2900	2500	2300	2100	2000	1900	1800	1700	1600	1500
165x60	3600	3200	2900	2700	2500	2400	2300	2200	2000	1900
195x60	4000	3600	3400	3200	3000	2900	2700	2600	2400	2300
230x60	4600	4100	3800	3600	3500	3300	3200	3000	2900	2700
260x60	5000	4500	4200	4000	3800	3700	3500	3400	3200	3100
295x60	5500	5000	4600	4400	4200	4000	3900	3800	3700	3500
330x60	6000	5400	5000	4800	4600	4400	4200	4100	4000	3900
360x60	6400	5800	5400	5100	4900	4700	4500	4400	4300	4200
130x75	3100	2700	2500	2300	2100	2000	1900	1800	1800	1700
165x75	3800	3400	3100	2900	2700	2600	2500	2400	2300	2200
195x75	4300	3900	3600	3400	3200	3100	2900	2800	2700	2600
230x75	4800	4400	4100	3800	3700	3500	3400	3300	3200	3000
260x75	5300	4800	4500	4200	4000	3900	3700	3600	3500	3400
295x75	5800	5300	4900	4600	4400	4300	4100	4000	3900	3800
330x75	6300	5700	5300	5000	4800	4600	4500	4400	4200	4100
360x75	6800	6100	5700	5400	5100	5000	4800	4600	4500	4400
	<b>Continuous span</b>									
130x60	3500	3000	2600	2300	2100	1900	1800	1700	1600	1500
165x60	4100	3700	3300	2900	2700	2500	2300	2200	2000	1900
195x60	4700	4200	3900	3500	3200	2900	2700	2600	2400	2300
230x60	5300	4800	4500	4100	3700	3500	3200	3000	2900	2700
260x60	5800	5300	4900	4600	4200	3900	3600	3400	3200	3100
295x60	6400	5800	5400	5100	4800	4400	4100	3900	3700	3500
330x60	7000	6300	5900	5500	5300	4900	4600	4300	4100 <sub>5</sub>	3900 <sub>10</sub>
360x60	7400	6700	6300	5900	5700	5400	5000	4700 <sub>10</sub>	4500 <sub>15</sub>	4300 <sub>20</sub>
130x75	3700	3300	2900	2600	2400	2200	2000	1900	1800	1700
165x75	4400	3900	3700	3300	3000	2800	2600	2400	2300	2200
195x75	5000	4500	4200	3900	3500	3300	3000	2900	2700	2600
230x75	5600	5100	4700	4500	4200	3900	3600	3400	3200	3000
260x75	6100	5600	5200	4900	4700	4400	4100	3800	3600	3400
295x75	6800	6100	5700	5400	5100	4900	4600	4300	4100	3900
330x75	7400	6700	6200	5900	5600	5400	5100	4800	4600	4400
360x75	7800	7100	6600	6300	6000	5800	5600	5300	5000 <sub>5</sub>	4800 <sub>10</sub>

### NOTES:

1. D = member depth, B = member breadth, NS = not suitable.
2. End bearing lengths = 70 mm at end supports and 90 mm at internal supports for continuous members. Subscript values indicate the minimum additional bearing length where required to be greater than 70 mm at end supports and 90 mm at internal supports.
3. Restraint value for slenderness calculations is 600 mm. (floor joist centres at 600 mm max)
4. Not all sizes of SmartLam GL19C in this table are stocked in each state. Please check with your supplier before ordering

# Floor bearers supporting single storey load bearing wall - sheet and tiled roof

## Single and Continuous span

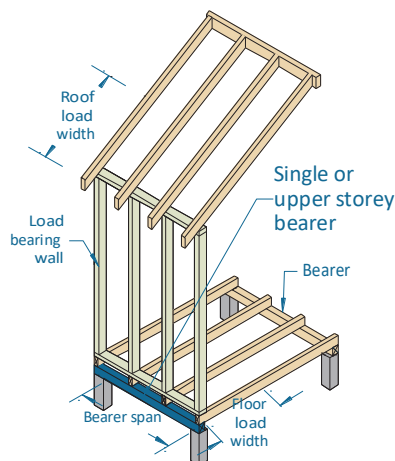

### EXAMPLE:

Sheet roof - 40 kg/m<sup>2</sup>  
 floor load width = 2000 mm  
 roof load width = 1950 mm  
 bearer span = 3000 mm (single span)

Enter single span table at 2400 mm in floor load width column, 4500 roof load width column, read down to a span equal to or greater than 3000 mm in the 40 kg/m<sup>2</sup> row

### ADOPT:

SmartLam GL19 C- 230 x 60

### Floor mass - 40 kg/m<sup>2</sup>

Floor load width (mm)		1200			2400			4800		
Roof load width (mm)		1500	4500	7500	1500	4500	7500	1500	4500	7500
Member size DxB (mm)	Roof mass (kg/m <sup>2</sup> )	Maximum recommended bearer span (mm)								
		Single span								
130x60	40	2200	1900	1600	1900	1700	1500	1600	1500	1400
	90	2000	1600	1400	1800	1500	1300	1600	1400	1200
165x60	40	2800	2400	2100	2500	2200	2000	2100	1900	1800
	90	2600	2100	1800	2300	2000	1700	2000	1800	1600
195x60	40	3300	2900	2500	3000	2600	2400	2500	2300	2100
	90	3100	2500	2100	2800	2300	2100	2400	2100	1900
230x60	40	3900	3400	3000	3500	3100	2800	3000	2700	2500
	90	3600	2900	2500	3300	2800	2400	2800	2500	2300
260x60	40	4300	3800	3400	3900	3600	3200	3400	3100	2900
	90	4000	3400	2900	3700	3200	2800	3200	2900	2600
295x60	40	4800	4200	3800	4300	4000	3700	3800	3600	3300
	90	4500	3800	3300	4100	3600	3200	3700	3300	3000
330x60	40	5300	4700	4200	4800	4400	4000	4200	3900	3700
	90	4900	4200	3700	4600	4000	3600	4000	3700	3300
360x60	40	5700	5000	4500	5200	4700	4300	4500	4200	4000
	90	5300	4500	4000	4900	4300	3900	4300	3900	3600
130x75	40	2400	2000	1800	2100	1800	1700	1700	1600	1500
	90	2200	1700	1500	2000	1600	1400	1700	1500	1300
165x75	40	3000	2600	2300	2700	2400	2100	2200	2100	1900
	90	2800	2200	1900	2500	2100	1900	2200	1900	1700
195x75	40	3600	3100	2700	3200	2800	2600	2700	2500	2300
	90	3300	2700	2300	3000	2500	2200	2600	2300	2100
230x75	40	4100	3700	3200	3700	3400	3100	3200	3000	2700
	90	3900	3200	2800	3600	3000	2600	3100	2700	2500
260x75	40	4600	4000	3700	4200	3800	3500	3600	3400	3100
	90	4300	3600	3100	4000	3400	3000	3500	3100	2800
295x75	40	5100	4500	4100	4600	4200	3900	4000	3800	3600
	90	4800	4000	3600	4400	3800	3400	3900	3500	3200
330x75	40	5600	5000	4500	5100	4600	4300	4400	4200	3900
	90	5300	4400	3900	4900	4200	3800	4300	3900	3600
360x75	40	6100	5400	4800	5500	5000	4600	4800	4500	4200
	90	5700	4800	4200	5200	4500	4100	4600	4200	3900
<b>Continuous span</b>										
130x60	40	2800	2400	2000	2300	2100	1900	1700	1600	1500
	90	2600	2000	1600	2200	1800	1500	1600	1500	1300
165x60	40	3600	3100	2600	2900	2600	2400	2100	2000	1900
	90	3300	2500	2100	2800	2300	1900	2100	1900	1700
195x60	40	4100	3700	3100	3400	3100	2800	2500	2400	2300
	90	3800	3000	2400	3300	2700	2300	2500	2200	2000
230x60	40	4600	4100	3600	4000	3700	3300	3000	2800	2700
	90	4400	3500	2900	3900	3200	2700	2900	2600	2400
260x60	40	5100	4500	4100	4600	4200	3700	3400	3200	3000
	90	4800	4000	3300	4400	3700	3100	3300	3000	2700
295x60	40	5500	5000	4600	5100	4700	4200	3900	3700	3400
	90	5200	4500	3700	4900	4100	3500	3800	3400	3100 <sub>10</sub>
330x60	40	6000	5400	5000	5500	5100	4700	4300	4100 <sub>5</sub>	3800 <sub>10</sub>
	90	5700	4900	4100 <sub>5</sub>	5300	4600	3900 <sub>10</sub>	4200 <sub>5</sub>	3800 <sub>15</sub>	3500 <sub>25</sub>
360x60	40	6400	5800	5300	5900	5500	5100	4700 <sub>10</sub>	4500 <sub>15</sub>	4200 <sub>20</sub>
	90	6100	5200	4500 <sub>15</sub>	5700	5000	4200 <sub>20</sub>	4600 <sub>10</sub>	4200 <sub>25</sub>	3800 <sub>35</sub>

## Floor bearers supporting single storey load bearing wall - sheet and tiled roof - Continuous span (Cont'd)

Floor load width (mm)		1200			2400			4800		
Roof load width (mm)		1500	4500	7500	1500	4500	7500	1500	4500	7500
Member size DxB (mm)	Roof mass (kg/m <sup>2</sup> )	Maximum recommended continuous span bearer span (mm)								
		Continuous span								
130x75	40	3100	2600	2300	2600	2300	2100	1900	1800	1700
	90	2800	2200	1800	2400	2000	1700	1800	1700	1500
165x75	40	3800	3400	2900	3200	2900	2600	2400	2300	2100
	90	3600	2800	2300	3100	2600	2200	2300	2100	1900
195x75	40	4300	3900	3400	3800	3500	3100	2800	2700	2500
	90	4100	3400	2700	3600	3100	2600	2800	2500	2300
230x75	40	4900	4400	4000	4500	4100	3700	3400	3200	3000
	90	4600	3900	3200	4300	3600	3000	3300	3000	2700
260x75	40	5300	4800	4400	4900	4500	4200	3800	3600	3400
	90	5000	4300	3600	4700	4100	3400	3700	3400	3100
295x75	40	5800	5300	4800	5400	5000	4600	4300	4100	3800
	90	5500	4800	4100	5200	4600	3900	4200	3800	3500
330x75	40	6300	5700	5200	5800	5400	5000	4800	4600	4300
	90	6000	5200	4600	5600	5000	4300	4700	4300 <sub>5</sub>	3900 <sub>10</sub>
360x75	40	6800	6100	5600	6200	5800	5400	5300	5000 <sub>5</sub>	4700 <sub>10</sub>
	90	6400	5500	5000	6000	5300	4700 <sub>10</sub>	5100	4600 <sub>10</sub>	4200 <sub>20</sub>

### NOTES:

1. D = member depth, B = member breadth, NS = not suitable.
2. The above table was based on a maximum DL of 40 kg/m<sup>2</sup>, total ground floor mass of 40 kg/m<sup>2</sup>, total wall mass of 37 kg/m<sup>2</sup>, floor live load of 1.5 kPa, floor point load of 1.8 kN
3. The above table was based on a wall height of 2700 mm
4. End bearing lengths = 70 mm at end supports and 90 mm at internal supports for continuous members. Subscript values indicate the minimum additional bearing length where required to be greater than 70 mm at end supports and 90 mm at internal supports
5. Restraint value for slenderness calculations is 600 mm
6. Not all sizes of SmartLam GL19C in this table are stocked in each state. Please check with your supplier before ordering.



## Single span lintels in single/upper storey walls AS 4055 classification N1, N2 and N3

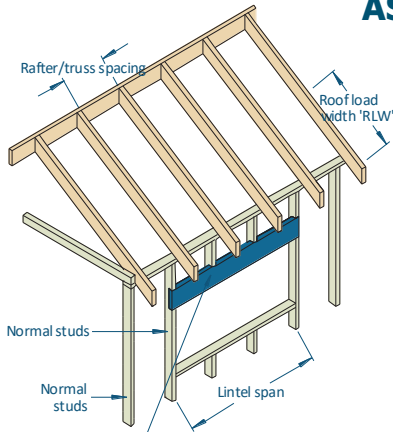

Single/Upper storey lintel

### EXAMPLE:

wind speed = N3  
sheet roof - 40 kg/m<sup>2</sup>  
roof load width = 3900 mm  
rafter/truss spacing = 600 mm  
lintel span = 3500 mm

Enter span table at 4500 roof load width column, rafter/truss spacing 600 mm, and read down to a span equal to or greater than 3500 mm in the 40 kg/m<sup>2</sup> row

### ADOPT:

SmartLam GL19C - 230 x 60

Roof load width (mm)		1500		3000		4500		6000		7500	
Rafter/Truss spacing (mm)		600	1200	600	1200	600	1200	600	1200	600	1200
Member size DxB (mm)	Roof mass (kg/m <sup>2</sup> )	Maximum recommended Lintel span (mm)									
		Single span									
130x60	40	3400	3400	2700	2800	2300	2400	2100	2100	1900	1900
	90	2700	2800	2100	2100	1900	1800	1600	1600	1500	1400
165x60	40	4100	4100	3400	3400	3000	3000	2700	2700	2400	2400
	90	3400	3400	2700	2800	2300	2400	2100	2100	2000	1900
195x60	40	4800	4800	3900	3900	3400	3400	3100	3100	2900	2900
	90	3900	3900	3200	3200	2800	2800	2500	2500	2300	2300
230x60	40	5500	5500	4500	4500	4000	3900	3600	3600	3300	3300
	90	4500	4500	3700	3600	3300	3200	3000	3000	2700	2800
260x60	40	6200	6100	5000	5000	4400	4400	4000	4000	3700	3700
	90	5000	5000	4100	4100	3600	3600	3300	3300	3100	3100
295x60	40	6900	6900	5600	5600	4900	4900	4400	4400	4100	4100
	90	5600	5600	4500	4500	4000	4000	3700	3700	3400	3400
330x60	40	7700	7700	6200	6200	5400	5400	4900	4900	4500	4500
	90	6200	6200	5000	5000	4400	4400	4100	4100 <sub>5</sub>	3800 <sub>5</sub>	3800
360x60	40	8400	8400	6800	6800	5900	5900	5300	5300	4900	4900
	90	6700	6700	5400	5400	4800	4800	4400	4400	4100 <sub>5</sub>	4100 <sub>5</sub>
130x75	40	3600	3600	3000	3000	2500	2600	2200	2300	2100	2000
	90	2900	2900	2300	2300	2000	2000	1800	1700	1600	1500
165x75	40	4400	4400	3600	3600	3200	3200	2900	2900	2600	2700
	90	3600	3600	3000	3000	2500	2600	2300	2300	2100	2100
195x75	40	5100	5100	4100	4100	3700	3600	3300	3300	3100	3100
	90	4100	4100	3400	3400	3000	3000	2700	2800	2500	2500
230x75	40	5800	5800	4800	4800	4200	4200	3800	3800	3500	3500
	90	4800	4800	3900	3900	3500	3400	3200	3200	3000	3000
260x75	40	6500	6500	5300	5300	4700	4700	4200	4200	3900	3900
	90	5300	5300	4300	4300	3900	3800	3500	3500	3300	3300
295x75	40	7300	7300	6000	6000	5200	5200	4700	4700	4400	4400
	90	6000	5900	4900	4800	4300	4300	3900	3900	3600	3600
330x75	40	8200	8200	6600	6600	5800	5800	5200	5300	4800	4800
	90	6600	6600	5400	5400	4700	4700	4300	4300	4000	4000
360x75	40	8900	8900	7200	7200	6300	6300	5700	5700	5200	5200
	90	7200	7200	5800	5800	5100	5100	4700	4600	4300	4300 <sub>5</sub>

## Single span lintels in single/upper storey walls AS 4055 classification C1, C2 and C3

Roof load width (mm)		1500		3000		4500		6000		7500	
Rafter/truss spacing (mm)		600	1200	600	1200	600	1200	600	1200	600	1200
Member size DxB (mm)	Roof mass (kg/m <sup>2</sup> )	Maximum recommended Lintel span (mm)									
		Single span									
130x60	40	2900	2800	2000	1900	1600	1200	1200	NS	NS	NS
	90	2700	2800	2000	1900	1600	1200	1200	NS	NS	NS
165x60	40	3800	3600	2500	2600	2100	2000	1800	1500	1600	1200
	90	3400	3400	2500	2600	2100	2000	1800	1500	1500	1200
195x60	40	4400	4400	3100	3000	2400	2400	2100	2100	1900 <sub>5</sub>	1700
	90	3900	3900	3100	3000	2400	2400	2100 <sub>5</sub>	2100	1900 <sub>10</sub>	1700 <sub>5</sub>
230x60	40	5300	5200	3700	3600	2900	2900	2500	2500 <sub>5</sub>	2200 <sub>5</sub>	2200 <sub>5</sub>
	90	4500	4500	3700	3500	2900	2900	2500	2500 <sub>10</sub>	2200 <sub>15</sub>	2200 <sub>10</sub>
260x60	40	5900	5900	4200	4100	3400	3300	2900	2800 <sub>10</sub>	2500 <sub>5</sub>	2600 <sub>15</sub>
	90	5000	5000	4100	4100	3400	3200	2800 <sub>5</sub>	2800 <sub>15</sub>	2500 <sub>10</sub>	2500 <sub>20</sub>

## Single span lintels in single/upper storey walls AS 4055 classification C1, C2 and C3

Roof load width (mm)		1500		3000		4500		6000		7500	
Rafter/truss spacing (mm)		600	1200	600	1200	600	1200	600	1200	600	1200
Member size DxB (mm)	Roof mass (kg/m <sup>2</sup> )	Maximum recommended Lintel span (mm)									
		Single span									
295x60	40	6500	6500	4700	4800	3900	3800	3400 <sub>5</sub>	3200 <sub>5</sub>	2900 <sub>5</sub>	2900 <sub>20</sub>
	90	5600	5600	4500	4500	3900 <sub>10</sub>	3700 <sub>5</sub>	3300 <sub>15</sub>	3200 <sub>10</sub>	2900 <sub>10</sub>	2800 <sub>30</sub>
330x60	40	7100	7100	5400	5300	4300 <sub>5</sub>	4300 <sub>5</sub>	3800 <sub>15</sub>	3600 <sub>10</sub>	3400 <sub>20</sub>	3200 <sub>15</sub>
	90	6200	6200	5000	5000 <sub>5</sub>	4300 <sub>10</sub>	4300 <sub>15</sub>	3700 <sub>20</sub>	3600 <sub>15</sub>	3300 <sub>30</sub>	3200 <sub>25</sub>
360x60	40	7500	7500	5800	5800	4700 <sub>5</sub>	4800 <sub>15</sub>	4100 <sub>15</sub>	4000 <sub>10</sub>	3700 <sub>25</sub>	3500 <sub>15</sub>
	90	6700	6700	5400 <sub>5</sub>	5400 <sub>5</sub>	4700 <sub>10</sub>	4700 <sub>10</sub>	4000 <sub>20</sub>	4000 <sub>15</sub>	3600 <sub>35</sub>	3500 <sub>25</sub>
130x75	40	3300	3200	2200	2200	1800	1600	1500	1100	1200	NS
	90	2900	2900	2200	2200	1800	1600	1500	1200	1200	NS
165x75	40	4200	4100	2900	2800	2300	2300	2000	1900	1800	1500
	90	3600	3600	2900	2800	2300	2300	2000	1900	1800	1500
195x75	40	5000	5000	3500	3400	2800	2800	2400	2400	2100	2100
	90	4100	4100	3400	3300	2700	2700	2300	2300	2100 <sub>5</sub>	2100
230x75	40	5700	5700	4100	4100	3400	3200	2800	2800	2500	2500 <sub>5</sub>
	90	4800	4800	3900	3900	3300	3200	2800	2800 <sub>5</sub>	2500	2500 <sub>10</sub>
260x75	40	6200	6200	4700	4700	3800	3700	3300	3200	2900	2900 <sub>10</sub>
	90	5300	5300	4300	4300	3800	3700	3200 <sub>5</sub>	3100 <sub>5</sub>	2800 <sub>5</sub>	2800 <sub>15</sub>
295x75	40	6900	6900	5400	5300	4300	4300	3800 <sub>5</sub>	3600	3400 <sub>5</sub>	3200 <sub>5</sub>
	90	6000	5900	4900	4800	4300	4200 <sub>5</sub>	3700 <sub>10</sub>	3600 <sub>5</sub>	3300 <sub>15</sub>	3200 <sub>10</sub>
330x75	40	7500	7500	6000	5900	4900	4900 <sub>5</sub>	4200 <sub>10</sub>	4200 <sub>10</sub>	3800 <sub>15</sub>	3600 <sub>10</sub>
	90	6600	6600	5400	5400	4700	4700 <sub>5</sub>	4100 <sub>15</sub>	4100 <sub>20</sub>	3700 <sub>20</sub>	3600 <sub>15</sub>
360x75	40	8000	8000	6500	6500	5400 <sub>5</sub>	5300 <sub>5</sub>	4600 <sub>5</sub>	4600 <sub>10</sub>	4100 <sub>15</sub>	4000 <sub>10</sub>
	90	7200	7200	5800	5800	5100 <sub>10</sub>	5100 <sub>10</sub>	4500 <sub>15</sub>	4500 <sub>15</sub>	4000 <sub>20</sub>	3900 <sub>15</sub>

### NOTES:

1. D = member depth, B = member breadth, NS = not suitable.
2. Minimum bearing length = 35 mm at end supports. Subscript values indicate the minimum additional bearing length where required to be greater than 35 mm
3. Restraint value for slenderness calculations is 600 mm
4. Not all sizes of SmartLam GL19C in this table are stocked in each state. Please check with your supplier before ordering

# Single span lintels in lower storey walls AS 4055 classification N1, N2, N3 & C1

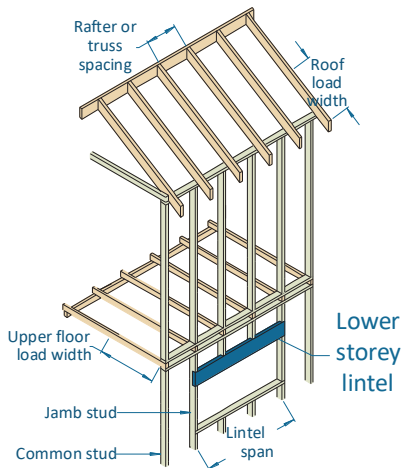

## EXAMPLE:

wind speed = N3  
 sheet roof - 40 kg/m<sup>2</sup>  
 rafter/truss spacing = 600 mm  
 lintel span = 3500 mm  
 roof load width = 3900 mm  
 floor load width = 1200 mm  
 Enter span table at 4500 roof load width column, floor load width 1200 mm, and read down to a span equal to or greater than 3500 mm in 40 kg/m<sup>2</sup> row

## ADOPT:

SmartLam GL19C- 260 x 60

Roof load width (mm)		1500			3000			4500			6000		
Floor load width (mm)		1200	2400	3600	1200	2400	3600	1200	2400	3600	1200	2400	3600
Member size DxB (mm)	Roof mass (kg/m <sup>2</sup> )	Maximum recommended Lintel span (mm)											
		Single span											
130x60	40	2200	2000	1800	2100	1900	1700	1900	1800	1700	1800	1700	1600
	90	2100	1900	1700	1800	1700	1600	1700	1600	1500	1500	1500	1400
165x60	40	2900	2600	2300	2700	2400	2200	2500	2300	2100	2300	2200	2000
	90	2700	2400	2200	2400	2200	2100	2200	2000	1900	2000	1900	1800
195x60	40	3300	3000	2800	3100	2900	2700	3000	2700	2500	2800	2600	2400
	90	3100	2900	2700	2800	2600	2500	2600	2400	2300	2400	2300	2200
230x60	40	3800	3500	3200	3600	3300	3100	3400	3200	3000	3200	3100	2900
	90	3600	3300	3100	3300	3100	2900	3000	2900	2700	2800	2700	2600
260x60	40	4200	3800	3600	4000	3700	3400	3800	3500	3300	3600	3400	3200
	90	4000	3700	3400	3600	3400	3200	3400	3200	3100	3200	3000	2900
295x60	40	4700	4300	4000	4400	4100	3800	4200	3900	3700	4000	3800	3600
	90	4400	4100	3800	4000	3800	3600	3700	3600	3400	3500	3400	3300 <sub>5</sub>
330x60	40	5200	4700	4400	4900	4500	4200	4600	4300	4100	4400	4100	3900 <sub>5</sub>
	90	4900	4500	4200	4400	4200	4000 <sub>5</sub>	4100	3900	3800 <sub>5</sub>	3900	3700 <sub>5</sub>	3600 <sub>10</sub>
360x60	40	5600	5100	4700	5300	4900	4500 <sub>5</sub>	5000	4600	4400 <sub>5</sub>	4700	4400	4200 <sub>5</sub>
	90	5300	4900	4500 <sub>5</sub>	4800	4500	4300 <sub>5</sub>	4400	4200	4000 <sub>10</sub>	4100 <sub>5</sub>	4000 <sub>5</sub>	3900 <sub>10</sub>
130x75	40	2400	2200	2000	2200	2000	1900	2100	1900	1800	2000	1800	1700
	90	2200	2000	1900	2000	1800	1700	1800	1700	1600	1700	1600	1500
165x75	40	3100	2800	2500	2900	2600	2400	2700	2500	2300	2500	2300	2200
	90	2900	2600	2400	2600	2400	2200	2300	2200	2100	2200	2100	2000
195x75	40	3500	3200	3000	3300	3100	2900	3100	2900	2700	3000	2800	2600
	90	3300	3100	2900	3000	2800	2700	2800	2600	2500	2600	2500	2300
230x75	40	4100	3700	3400	3800	3500	3300	3600	3400	3200	3400	3200	3100
	90	3800	3500	3300	3500	3300	3100	3200	3100	3000	3000	2900	2800
260x75	40	4500	4100	3800	4200	3900	3700	4000	3700	3500	3800	3600	3400
	90	4200	3900	3700	3800	3600	3400	3600	3400	3300	3400	3200	3100
295x75	40	5000	4600	4200	4700	4300	4100	4400	4200	3900	4200	4000	3800
	90	4700	4300	4100	4300	4000	3800	4000	3800	3600	3700	3600	3500
330x75	40	5500	5000	4700	5200	4800	4500	4900	4600	4300	4600	4400	4200
	90	5200	4800	4500	4700	4400	4200	4400	4200	4000	4100	4000	3800
360x75	40	6000	5400	5000	5600	5200	4800	5300	4900	4700	5000	4700	4500
	90	5600	5200	4800	5100	4800	4500	4700	4500	4300	4400	4300	4100 <sub>5</sub>

## NOTES:

1. D = member depth, B = member breadth, NS = not suitable.
2. Total Upper floor mass of 40 kg/m<sup>2</sup>, floor live load of 1.5 kPa, floor point load of 1.8 kN
3. Minimum bearing length = 35 mm at end supports. Subscript values indicate the minimum additional bearing length where required to be greater than 35 mm.
4. Restraint value for slenderness calculations is 600 mm.
5. Not all sizes of SmartLam GL19C in this table are stocked in each state. Please check with your supplier before ordering

# Single/continuous span roof rafter - AS 4055 classification N1, N2 AND N3 - with ceiling attached

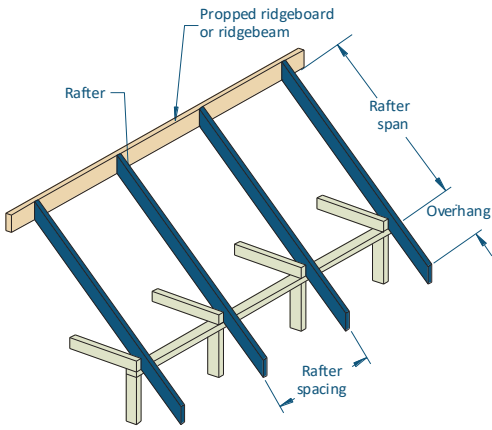

Maximum Birdsmouth = 30% of rafter depth

### EXAMPLE:

wind speed = N3  
sheet roof - 40 kg/m<sup>2</sup>  
rafter/truss spacing = 600 mm  
rafter span = 5000 mm

Enter span table at rafter spacing of 600 mm, and read down to a span equal to or greater than 5000 mm in 40 kg/m<sup>2</sup> row

### ADOPT:

SmartLam GL19C - 165 x 60

Rafter spacing (mm)		450	600	900	1200	450	600	900	1200
Member size DxB (mm)	Roof mass (kg/m <sup>2</sup> )	Maximum recommended Rafter span (mm)							
		Single span				Continuous span			
130x60	30	5300	5200	4600	4300	6300	6300	5800	5400
	40	5200	4800	4300	3900	6300	6000	5400	4900
	75	4400	4000	3500	3200	5400	5000	4500	4100
	90	4100	3800	3300	3000	5200	4800	4200	3900
165x60	30	6600	6400	5900	5500	7800	7400	6900	6500
	40	6400	6100	5500	5000	7400	7100	6500	6200
	75	5600	5100	4500	4100	6600	6200	5700	5200
	90	5300	4800	4200	3900	6400	6000	5300	4900
195x60	30	7800	7400	6800	6400	8600	8300	7700	7300
	40	7400	6900	6400	5900	8300	7900	7300	6900
	75	6500	6000	5400	4900	7400	7000	6400	6000
	90	6200	5700	5000	4600	7200	6800	6200	5800
230x60	30	8900	8400	7800	7300	9600	9200	8700	8200
	40	8400	8000	7300	6800	9200	8800	8200	7800
	75	7400	6900	6300	5800	8300	7900	7300	6800
	90	7100	6600	6000	5500	8000	7600	7000	6500
260x60	30	9800	9300	8600	8100	10300	10000	9400	9000
	40	9300	8800	8100	7600	10000	9600	9000	8500
	75	8200	7700	7000	6500	9000	8600	7900	7500
	90	7900	7400	6600	6200	8700	8300	7600	7200
295x60	30	10900	10400	9600	9000	11200	10800	10200	9700
	40	10400	9800	9000	8400	10800	10400	9800	9300
	75	9100	8600	7800	7200	9800	9400	8700	8200
	90	8800	8200	7400	6900	9500	9100	8300	7800
330x60	30	12000	11400	10600	10000	12000	11600	11000	10500
	40	11400	10800	10000	9300	11600	11200	10500	10000
	75	10100	9500	8600	8000	10600	10100	9400	8800
	90	9700	9100	8200	7600	10300	9800	9000	8500
360x60	30	12000	12000	11500	10800	12000	12000	11600	11100
	40	12000	11700	10800	10100	12000	11800	11100	10600
	75	10900	10200	9300	8600	11200	10700	10000	9400
	90	10500	9800	8800	8200	10900	10400	9600	9000
130x75	30	5700	5500	4900	4600	6700	6600	6100	5700
	40	5500	5100	4600	4200	6600	6200	5700	5300
	75	4600	4300	3800	3400	5800	5400	4800	4400
	90	4400	4000	3500	3200	5500	5100	4500	4200
165x75	30	7100	6700	6200	5800	8000	7700	7200	6800
	40	6700	6400	5800	5300	7700	7300	6800	6400
	75	5900	5500	4800	4400	6900	6500	6000	5500
	90	5600	5200	4600	4100	6700	6300	5700	5200
195x75	30	8000	7700	7100	6700	8900	8600	8100	7700
	40	7700	7300	6700	6300	8500	8200	7700	7200
	75	6800	6400	5700	5200	7700	7300	6800	6400
	90	6500	6100	5400	4900	7400	7100	6500	6100
230x75	30	9200	8800	8100	7700	9800	9500	9000	8600
	40	8800	8300	7700	7200	9500	9100	8600	8100
	75	7800	7300	6600	6200	8600	8200	7600	7200
	90	7500	7000	6300	5900	8400	7900	7300	6900
260x75	30	10100	9700	9000	8500	10600	10300	9700	9300
	40	9700	9200	8500	8000	10300	9900	9300	8800
	75	8600	8100	7400	6900	9400	9000	8300	7800
	90	8300	7800	7000	6500	9100	8700	8000	7500



## Single/continuous span roof rafter - AS 4055 classification N1, N2 AND N3 - with ceiling attached (Cont'd)

Rafter spacing (mm)		450	600	900	1200	450	600	900	1200
Member size DxB (mm)	Roof mass (kg/m <sup>2</sup> )	Maximum recommended Rafter span (mm)							
		Single span				Continuous span			
295x75	30	11300	10800	10000	9500	11500	11100	10600	10100
	40	10800	10300	9500	8900	11100	10700	10100	9600
	75	9600	9000	8200	7600	10200	9700	9100	8500
	90	9200	8600	7800	7300	9900	9400	8700	8200
330x75	30	12000	11800	11000	10500	12000	11900	11400	10900
	40	11800	11300	10500	9800	11900	11500	10900	10400
	75	10600	10000	9100	8400	11000	10500	9800	9300
	90	10200	9600	8700	8000	10600	10200	9400	8900
360x75	30	12000	12000	11900	11300	12000	12000	12000	11500
	40	12000	12000	11300	10600	12000	12000	11500	11000
	75	11500	10800	9800	9100	11600	11100	10400	9800
	90	11000	10300	9400	8700	11300	10800	10000	9500

## Single/continuous span roof rafter AS 4055 classification C1, C2 and C3 - with ceiling attached

Rafter spacing mm		450	600	900	1200	450	600	900	1200
Member size DxB (mm)	Roof mass (kg/m <sup>2</sup> )	Maximum recommended Rafter span (mm)							
		Single span				Continuous span			
130x60	30	5300	4900	4100	3400	6000	5200	4100	3400
	40	5200	4800	4100	3500	6100	5200	4100	3500
	75	4300	4000	3500	3200	5400	5000	4200	3600
	90	4100	3800	3300	3000	5200	4800	4100	3500
165x60	30	6300	5900	5300	4500	7700	6600	5300	4500
	40	6300	5900	5300	4500	7400	6700	5300	4500
	75	5500	5100	4500	4100	6600	6200	5400	4600
	90	5300	4800	4200	3900	6400	6000	5300	4500
195x60	30	7100	6700	6000	5300	8600	7800	6300	5300
	40	7100	6700	6000	5400	8200	7900	6300	5400
	75	6500	6000	5400	4900	7400	7000	6400	5500
	90	6200	5700	5000	4600	7200	6800	6200	5400
230x60	30	8100	7500	6800	6300	9600	9200	7500	6300
	40	8100	7500	6800	6300	9200	8800	7500	6400
	75	7400	6900	6300	5800	8300	7900	7300	6500
	90	7100	6600	6000	5500	8000	7600	7000	6400
260x60	30	8900	8300	7500	7000	10300	10000	8500	7200
	40	8900	8300	7500	7000	10000	9600	8600	7300
	75	8200	7700	7000	6500	9000	8600	7900	7400
	90	7900	7400	6600	6200	8700	8300	7600	7200
295x60	30	9700	9100	8200	7600	11200	10800	9700	8200
	40	9800	9100	8200	7600	10800	10400	9700	8300
	75	9100	8600	7800	7200	9800	9400	8700	8200
	90	8800	8200	7400	6900	9500	9100	8300	7800
330x60	30	10600	9900	8900	8300	12000	11600	10900	9300
	40	10600	9900	8900	8300	11600	11200	10500	9400
	75	10100	9500	8600	8000	10600	10100	9400	8800
	90	9700	9100	8200	7600	10300	9800	9000	8500
360x60	30	11300	10600	9600	8900	12000	12000	11600	10100
	40	11300	10600	9600	8900	12000	11800	11100	10300
	75	10900	10200	9300	8600	11200	10700	10000	9400
	90	10500	9800	8800	8200	10900	10400	9600	9000
130x75	30	5600	5200	4600	3900	6800	5800	4600	3900
	40	5500	5100	4600	3900	6500	5900	4700	3900
	75	4600	4300	3800	3400	5800	5400	4700	4000
	90	4400	4000	3500	3200	5500	5100	4500	3900
165x75	30	6600	6200	5600	5000	8000	7400	5900	5000
	40	6700	6200	5600	5100	7600	7300	6000	5100
	75	5900	5500	4800	4400	6900	6500	6000	5200
	90	5600	5200	4600	4100	6700	6300	5700	5100
195x75	30	7500	7000	6400	5900	8900	8600	7100	6000
	40	7600	7000	6400	5900	8500	8200	7100	6100
	75	6800	6400	5700	5200	7700	7300	6800	6200
	90	6500	6100	5400	4900	7400	7100	6500	6000

## Single/continuous span roof rafter AS 4055 classification C1, C2 and C3 - with ceiling attached (Cont'd)

Rafter spacing (mm)		450	600	900	1200	450	600	900	1200
Member size DxB (mm)	Roof mass (kg/m <sup>2</sup> )	Maximum recommended Rafter span (mm)							
		Single span				Continuous span			
230x75	30	8500	8000	7200	6700	9800	9500	8400	7100
	40	8600	8000	7200	6700	9500	9100	8500	7200
	75	7800	7300	6600	6200	8600	8200	7600	7200
	90	7500	7000	6300	5900	8400	7900	7300	6900
260x75	30	9400	8800	7900	7400	10600	10300	9500	8100
	40	9400	8800	7900	7400	10300	9900	9300	8200
	75	8600	8100	7400	6900	9400	9000	8300	7800
	90	8300	7800	7000	6500	9100	8700	8000	7500
295x75	30	10300	9600	8700	8100	11400	11100	10600	9300
	40	10300	9600	8700	8100	11100	10700	10100	9400
	75	9600	9000	8200	7600	10200	9700	9100	8500
	90	9200	8600	7800	7300	9900	9400	8700	8200
330x75	30	11200	10500	9500	8800	12000	11900	11400	10400
	40	11200	10500	9500	8800	11900	11500	10900	10400
	75	10600	10000	9100	8400	11000	10500	9800	9300
	90	10200	9600	8700	8000	10600	10200	9400	8900
360x75	30	12000	11200	10100	9400	12000	12000	12000	11400
	40	12000	11200	10100	9400	12000	12000	11500	11000
	75	11500	10800	9800	9100	11600	11100	10400	9800
	90	11000	10300	9400	8700	11300	10800	10000	9500

### NOTES:

1. D = member depth, B = member breadth, NS = not suitable.
2. The above table was based on a batten spacing of 900 mm
3. Maximum birds mouth depth = 30 % of rafter depth
4. End bearing lengths = 45 mm at end supports and 45 mm at internal supports for continuous members. Subscript values indicate the minimum additional bearing length where required to be greater than 45 mm at end supports and 45 mm at internal supports
5. Construction loads shall not be applied to overhangs until a 190 x 19 (minimum) timber fascia or other fascia of equivalent stiffness is rigidly and permanently attached to the end of rafter overhangs
6. Rafter spacing up to 1200 mm
7. Not all sizes of SmartLam GL19C in this table are stocked in each state. Please check with your supplier before ordering

# Single/continuous span roof rafter- AS 4055 classification N1, N2 and N3 - without ceiling attached

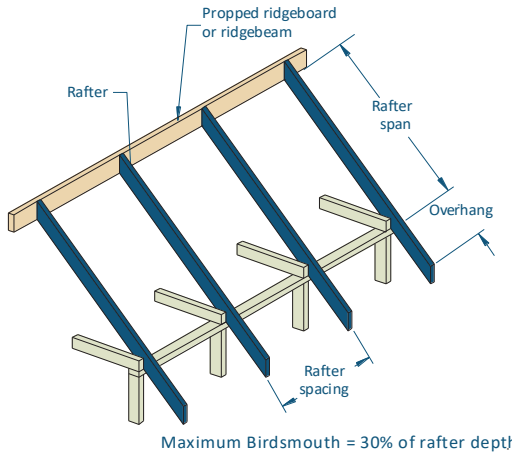

Maximum Birds-mouth = 30% of rafter depth

### EXAMPLE:

wind speed = N3  
sheet roof - 40 kg/m<sup>2</sup>  
rafter/truss spacing = 600 mm  
rafter span = 5000 mm

Enter span table at rafter spacing of 600 mm, and read down to a span equal to or greater than 5000 mm in 40 kg/m<sup>2</sup> row

### ADOPT:

SmartLam GL19C - 165 x 60

Rafter spacing (mm)		450	600	900	1200	450	600	900	1200
Member size DxB (mm)	Roof mass (kg/m <sup>2</sup> )	Maximum recommended Rafter span (mm)							
		Single span				Continuous span			
130x60	10	5300	5300	5100	5000	6300	6300	6300	6300
	20	5400	5300	5100	4800	6300	6300	6300	6000
	40	5200	4800	4300	3900	6300	6000	5400	4900
	60	4600	4300	3800	3400	5800	5400	4800	4400
165x60	10	6700	6600	6400	6000	8000	8000	8000	7600
	20	6700	6600	6400	6000	8000	7900	7400	7100
	40	6400	6100	5500	5000	7400	7100	6500	6200
	60	5900	5500	4800	4400	6900	6500	6000	5500
195x60	10	7800	7700	7300	6800	9400	9500	9100	8600
	20	7900	7700	7300	6800	9100	8800	8300	7900
	40	7400	6900	6400	5900	8300	7900	7300	6900
	60	6800	6400	5700	5200	7700	7300	6800	6400
230x60	10	9100	9000	8300	7700	10600	10500	10100	9700
	20	9200	9000	8300	7700	10000	9700	9200	8800
	40	8400	8000	7300	6800	9200	8800	8200	7800
	60	7800	7300	6600	6200	8600	8200	7600	7200
260x60	10	10200	10100	9100	8500	11400	11200	10800	10500
	20	10300	10000	9100	8500	10800	10500	10000	9600
	40	9300	8800	8100	7600	10000	9600	9000	8500
	60	8600	8100	7400	6900	9400	9000	8300	7800
295x60	10	11500	11100	10000	9300	12000	12000	11700	11400
	20	11500	11000	10000	9300	11600	11400	10800	10400
	40	10400	9800	9000	8400	10800	10400	9800	9300
	60	9600	9000	8200	7600	10200	9700	9100	8500
330x60	10	12000	12000	10900	10100	12000	12000	12000	12000
	20	12000	12000	10900	10100	12000	12000	11600	11200
	40	11400	10800	10000	9300	11600	11200	10500	10000
	60	10600	10000	9100	8400	11000	10500	9800	9300
360x60	10	12000	12000	11600	10800	12000	12000	12000	12000
	20	12000	12000	11600	10800	12000	12000	12000	11800
	40	12000	11700	10800	10100	12000	11800	11100	10600
	60	11500	10800	9800	9100	11600	11100	10400	9800
130x75	10	5700	5700	5500	5300	6800	6800	6800	6700
	20	5800	5700	5500	5100	6800	6800	6600	6200
	40	5500	5100	4600	4200	6600	6200	5700	5300
	60	4900	4600	4000	3700	6100	5700	5100	4700
165x75	10	7200	7100	6800	6400	8600	8600	8400	8000
	20	7200	7100	6700	6400	8400	8100	7700	7300
	40	6700	6400	5800	5300	7700	7300	6800	6400
	60	6200	5800	5200	4700	7200	6800	6300	5900
195x75	10	8400	8300	7700	7200	9800	9700	9300	9000
	20	8500	8200	7700	7200	9300	9000	8600	8200
	40	7700	7300	6700	6300	8500	8200	7700	7200
	60	7100	6700	6100	5600	8000	7700	7100	6700
230x75	10	9800	9700	8800	8200	10800	10600	10300	10000
	20	9700	9300	8800	8200	10300	10000	9500	9100
	40	8800	8300	7700	7200	9500	9100	8600	8100
	60	8100	7700	7000	6500	8900	8600	7900	7500
260x75	10	11000	10600	9600	9000	11500	11400	11100	10800
	20	10700	10300	9600	9000	11000	10800	10300	9900
	40	9700	9200	8500	8000	10300	9900	9300	8800
	60	9000	8500	7800	7200	9700	9300	8700	8200

## Single/continuous span roof rafter- AS 4055 classification N1, N2 and N3 - without ceiling attached (Cont'd)

Rafter spacing (mm)		450	600	900	1200	450	600	900	1200
Member size DxB (mm)	Roof mass (kg/m <sup>2</sup> )	Maximum recommended Rafter span (mm)							
		Single span				Continuous span			
295x75	10	12000	11700	10600	9900	12000	12000	11900	11600
	20	11800	11400	10600	9900	11900	11600	11100	10700
	40	10800	10300	9500	8900	11100	10700	10100	9600
	60	10000	9500	8600	8100	10500	10100	9400	8900
330x75	10	12000	12000	11500	10700	12000	12000	12000	12000
	20	12000	12000	11500	10700	12000	12000	11900	11500
	40	11800	11300	10500	9800	11900	11500	10900	10400
	60	11100	10500	9600	8900	11300	10900	10200	9700
360x75	10	12000	12000	12000	11400	12000	12000	12000	12000
	20	12000	12000	12000	11400	12000	12000	12000	12000
	40	12000	12000	11300	10600	12000	12000	11500	11000
	60	11900	11300	10300	9600	12000	11500	10800	10300

## Single/continuous span roof rafter AS 4055 classification C1, C2 and C3 - without ceiling attached

Rafter spacing (mm)		450	600	900	1200	450	600	900	1200
Member size DxB (mm)	Roof mass (kg/m <sup>2</sup> )	Maximum recommended Rafter span (mm)							
		Single span				Continuous span			
130x60	10	5300	4900	4000	3400	5900	5000	4000	3400
	20	5300	4900	4100	3400	6000	5100	4100	3400
	40	5200	4800	4100	3500	6100	5200	4100	3500
	60	4600	4300	3800	3400	5800	5300	4200	3600
165x60	10	6300	5900	5200	4400	7600	6500	5200	4400
	20	6300	5900	5200	4400	7600	6500	5200	4400
	40	6300	5900	5300	4500	7400	6700	5300	4500
	60	5900	5500	4800	4400	6900	6500	5400	4600
195x60	10	7100	6700	6000	5200	9000	7700	6100	5200
	20	7100	6700	6000	5300	9000	7800	6200	5300
	40	7100	6700	6000	5400	8200	7900	6300	5400
	60	6800	6400	5700	5200	7700	7300	6500	5500
230x60	10	8100	7500	6800	6200	10200	9100	7300	6200
	20	8100	7500	6800	6300	10000	9200	7400	6300
	40	8100	7500	6800	6300	9200	8800	7500	6400
	60	7800	7300	6600	6200	8600	8200	7600	6600
260x60	10	8900	8300	7500	7000	11100	10400	8300	7100
	20	8900	8300	7500	7000	10800	10400	8400	7100
	40	8900	8300	7500	7000	10000	9600	8600	7300
	60	8600	8100	7400	6900	9400	9000	8300	7500
295x60	10	9800	9100	8200	7600	12000	11400	9500	8100
	20	9700	9100	8200	7600	11600	11400	9600	8100
	40	9700	9100	8200	7600	10800	10400	9700	8300
	60	9600	9000	8200	7600	10200	9700	9100	8500
330x60	10	10600	9900	8900	8300	12000	12000	10600	9100
	20	10600	9900	8900	8300	12000	12000	10700	9200
	40	10600	9900	8900	8300	11600	11200	10500	9400
	60	10600	9900	8900	8300	11000	10500	9800	9300
360x60	10	11300	10600	9600	8900	12000	12000	11600	9900
	20	11300	10600	9600	8900	12000	12000	11800	10000
	40	11300	10600	9600	8900	12000	11800	11100	10300
	60	11300	10600	9600	8900	11600	11100	10400	9800
130x75	10	5600	5200	4500	3800	6600	5700	4500	3800
	20	5600	5200	4600	3800	6700	5700	4600	3800
	40	5500	5100	4600	3900	6500	5900	4700	3900
	60	4900	4600	4000	3700	6100	5700	4800	4000
165x75	10	6600	6200	5600	4900	8400	7300	5800	4900
	20	6700	6200	5600	5000	8400	7300	5900	5000
	40	6700	6200	5600	5100	7600	7300	6000	5100
	60	6200	5800	5200	4700	7200	6800	6100	5200

## Single/continuous span roof rafter AS 4055 classification C1, C2 and C3 - without ceiling attached (Cont'd)

Rafter spacing (mm)		450	600	900	1200	450	600	900	1200
Member size DxB (mm)	Roof mass (kg/m <sup>2</sup> )	Maximum recommended Rafter span (mm)							
		Single span				Continuous span			
195x75	10	7500	7000	6400	5900	9500	8600	6900	5900
	20	7600	7000	6400	5900	9300	8700	7000	5900
	40	7600	7000	6400	5900	8500	8200	7100	6100
	60	7100	6700	6100	5600	8000	7700	7100	6200
230x75	10	8500	8000	7200	6700	10700	10000	8200	7000
	20	8600	8000	7200	6700	10200	10000	8300	7100
	40	8600	8000	7200	6700	9500	9100	8500	7200
	60	8100	7700	7000	6500	8900	8600	7900	7400
260x75	10	9400	8800	7900	7400	11500	11000	9300	8000
	20	9400	8800	7900	7400	11000	10800	9400	8000
	40	9400	8800	7900	7400	10300	9900	9300	8200
	60	9000	8500	7800	7200	9700	9300	8700	8200
295x75	10	10300	9600	8700	8100	12000	12000	10700	9100
	20	10300	9600	8700	8100	11800	11600	10800	9200
	40	10300	9600	8700	8100	11100	10700	10100	9400
	60	10000	9500	8600	8100	10500	10100	9400	8900
330x75	10	11200	10500	9500	8800	12000	12000	11900	10200
	20	11200	10500	9500	8800	12000	12000	11900	10300
	40	11200	10500	9500	8800	11900	11500	10900	10400
	60	11100	10400	9400	8800	11300	10900	10200	9700
360x75	10	12000	11200	10100	9400	12000	12000	12000	11200
	20	12000	11200	10100	9400	12000	12000	12000	11300
	40	12000	11200	10100	9400	12000	12000	11500	11000
	60	11900	11200	10100	9400	11900	11500	10800	10300

### NOTES:

1. D = member depth, B = member breadth, NS = not suitable.
2. The above table was based on a batten spacing of 900 mm
3. Maximum birds mouth depth = 30 % of rafter depth
4. End bearing lengths = 45 mm at end supports and 45 mm at internal supports for continuous members. Subscript values Indicate the minimum additional bearing length where required to be greater than 45 mm at end supports and 45 mm at internal supports
5. Construction loads shall not be applied to overhangs until a 190 x 19 (minimum) timber fascia or other fascia of equivalent stiffness is rigidly and permanently attached to the end of rafter overhangs
6. Rafter spacing up to 1200 mm
7. Not all sizes of SmartLam GL19C in this table are stocked in each state. Please check with your supplier before ordering



## Ridge/intermediate roof beam AS 4055 classification N1, N2 and N3

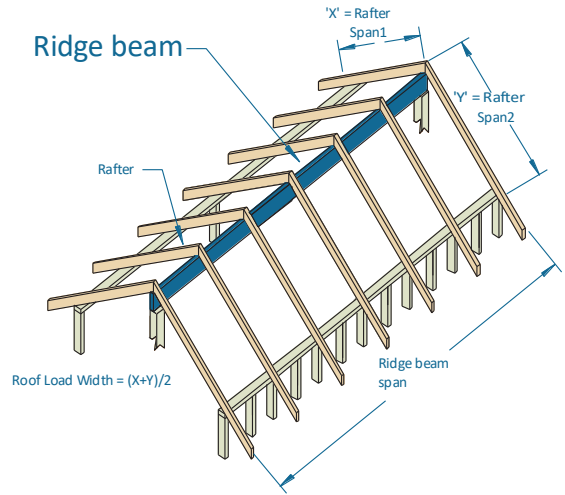
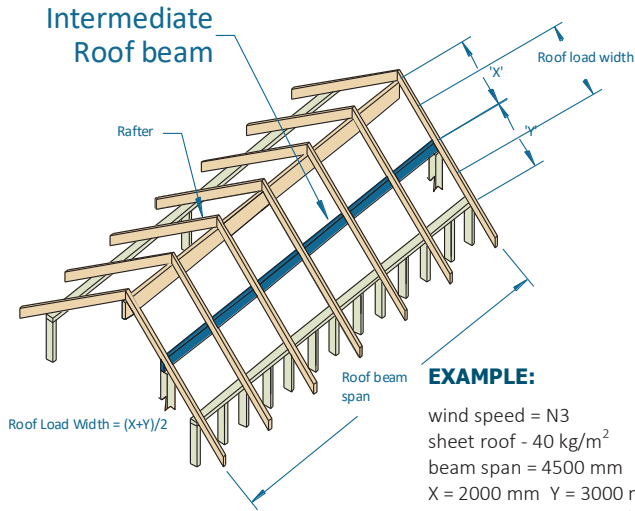

**EXAMPLE:**

wind speed = N3  
 sheet roof - 40 kg/m<sup>2</sup>  
 beam span = 4500 mm  
 X = 2000 mm Y = 3000 mm  
 roof load width = (X+Y)/2 = 2500 mm  
 Enter single span table at 3000 roof load width with  
 column And read down to span equal to or greater  
 than 4500 mm in 40 kg/m<sup>2</sup> row

**ADOPT: SmartLam GL19C - 230 x 60**

Roof load width (mm)		1500	3000	4500	6000	7500	1500	3000	4500	6000	7500
Member size DxB (mm)	Roof mass (kg/m <sup>2</sup> )	Maximum recommended Ridge /Intermediate beam span (mm)									
		Single span					Continuous span				
130x60	40	3600	2800	2400	2100	1900	4500	3600	2900	2500	2200
	90	2700	2100	1800	1600	1500	3500	2800	2300	2000	1700
165x60	40	4500	3500	3000	2700	2400	5700	4500	3600	3100	2800
	90	3500	2800	2400	2100	1900	4500	3600	2900	2500	2200
195x60	40	5400	4200	3600	3200	2900	6500	5300	4300	3700	3300
	90	4200	3300	2800	2500	2300	5300	4200	3500	3000	2600
230x60	40	6300	5000	4300	3800	3500	7300	6200	5100	4300	3900
	90	5000	3900	3400	3000	2800	6200	5000	4100	3500	3100
260x60	40	7000	5800	4900	4400	4000	8000	6800	5700	4900	4400
	90	5700	4500	3800	3400	3200	6700	5600	4600	3900	3500
295x60	40	7900	6500	5600	5000	4500	8700	7400	6500	5600	4900
	90	6400	5100	4400	3900	3600	7400	6300	5200	4500	4000
330x60	40	8700	7100	6300	5600	5100	9400	8100	7200	6200	5500
	90	7100	5800	5000	4400	4100	8000	6800	5800	5000	4400
360x60	40	9400	7700	6800	6100	5600	10000	8600	7700	6800	6000
	90	7700	6300	5500	4900	4500	8500	7300	6300	5400	4800
130x75	40	3800	3000	2500	2300	2000	4800	3800	3200	2700	2400
	90	3000	2300	2000	1800	1600	3800	3000	2600	2200	1900
165x75	40	4900	3800	3300	2900	2600	6000	4900	4100	3500	3100
	90	3800	3000	2600	2300	2100	4800	3800	3300	2800	2500
195x75	40	5800	4600	3900	3500	3100	6800	5700	4800	4100	3600
	90	4500	3600	3100	2700	2500	5600	4500	3900	3300	2900
230x75	40	6700	5400	4600	4100	3700	7700	6500	5600	4900	4300
	90	5400	4200	3600	3300	3000	6500	5300	4600	3900	3400
260x75	40	7400	6100	5300	4700	4300	8300	7100	6400	5500	4900
	90	6100	4800	4200	3700	3400	7100	6000	5100	4400	3900
295x75	40	8300	6800	6000	5400	4900	9100	7800	7000	6200	5500
	90	6800	5500	4800	4300	3900	7800	6600	5800	5000	4400
330x75	40	9100	7500	6700	6100	5500	9800	8500	7600	6900	6200
	90	7500	6200	5400	4800	4400	8400	7200	6500	5600	4900
360x75	40	9900	8200	7200	6500	6000	10400	9000	8100	7500	6700
	90	8100	6700	5900	5300	4800	9000	7600	6900	6100	5400

## Ridge/intermediate roof beam AS 4055 classification C1, C2 and C3

Roof load width (mm)		1500	3000	4500	6000	7500	1500	3000	4500	6000	7500
Member size DxB (mm)	Roof mass (kg/m <sup>2</sup> )	Maximum recommended Ridge /Intermediate beam span (mm)									
		Single span					Continuous span				
130x60	40	3000	2100	1700	1500	1300	3000	2100	1700	1500	1300
	90	2700	2100	1700	1500	1300	3000	2100	1700	1500	1300
165x60	40	3900	2700	2200	1900	1700	3900	2700	2200	1900	1700
	90	3500	2700	2200	1900	1700	3900	2700	2200	1900	1700
195x60	40	4700	3200	2600	2200	2000	4700	3200	2600	2200	2000
	90	4200	3200	2600	2200	2000	4700	3200	2600	2200	2000
230x60	40	5600	3800	3100	2700	2400	5600	3800	3100	2700	2400
	90	5000	3700	3000	2600	2300	5600	3700	3000	2600	2300
260x60	40	6400	4200	3500	3000	2700	6400	4200	3500	3000	2700
	90	5700	4200	3400	3000	2600	6300	4200	3400	3000	2600
295x60	40	7200	4800	3900	3400	3100	7300	4800	3900	3400	3100
	90	6400	4800	3900	3400	3000	7200	4800	3900	3400	3000
330x60	40	7800	5400	4400	3800	3400	8300	5400	4400	3800	3400
	90	7100	5300	4400	3800	3400	8000	5300	4400	3800	3400 <sub>s</sub>
360x60	40	8400	5900	4800	4200	3700	9100	5900	4800	4200	3700 <sub>s</sub>
	90	7700	5800	4800	4100	3700	8500	5800	4800	4100 <sub>s</sub>	3700 <sub>20</sub>
130x75	40	3400	2400	1900	1700	1500	3400	2400	1900	1700	1500
	90	3000	2300	1900	1600	1500	3400	2300	1900	1600	1500
165x75	40	4400	3000	2400	2100	1900	4400	3000	2400	2100	1900
	90	3800	3000	2400	2100	1900	4400	3000	2400	2100	1900
195x75	40	5300	3600	2900	2500	2200	5300	3600	2900	2500	2200
	90	4500	3500	2900	2500	2200	5300	3500	2900	2500	2200
230x75	40	6300	4200	3400	3000	2700	6400	4200	3400	3000	2700
	90	5400	4200	3400	2900	2600	6300	4200	3400	2900	2600
260x75	40	6900	4800	3900	3400	3000	7200	4800	3900	3400	3000
	90	6100	4700	3800	3300	2900	7100	4700	3800	3300	2900
295x75	40	7600	5400	4400	3800	3400	8300	5400	4400	3800	3400
	90	6800	5300	4400	3800	3400	7800	5300	4400	3800	3400
330x75	40	8300	6100	4900	4300	3800	9300	6100	4900	4300	3800
	90	7500	6000	4900	4200	3700	8400	6000	4900	4200	3700
360x75	40	8900	6700	5400	4700	4200	10200	6700	5400	4700	4200
	90	8100	6600	5300	4600	4100	9000	6600	5300	4600	4100 <sub>s</sub>

### NOTES:

1. D = member depth, B = member breadth, NS = not suitable
2. End bearing lengths = 70 mm at end supports and 90 mm at internal supports for continuous members. Subscript values indicate the minimum additional bearing length where required to be greater than 70 mm at end supports and 90 mm at internal supports
3. Rafter spacing up to 1200 mm
4. Not all sizes of SmartLam GL19C in this table are stocked in each state. Please check with your supplier before ordering

# Single span verandah beam AS 4055 classification N1, N2 and N3

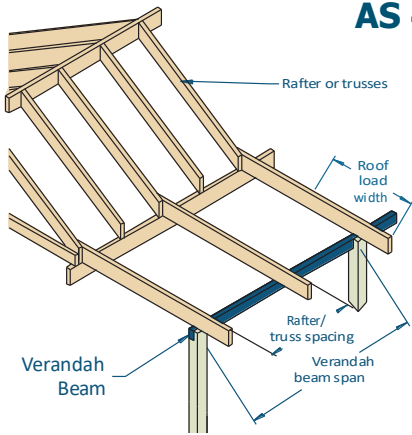

### EXAMPLE:

wind speed = N3  
sheet roof - 40 kg/m<sup>2</sup>  
rafter/truss spacing = 600 mm  
verandah span = 3500 mm (single span)  
roof load width = 3900 mm

Enter span table at 4500 roof load width column, rafter spacing of 600 mm, and read down to a span equal to or greater than 3500 mm in 40 kg/m<sup>2</sup> row

### ADOPT:

SmartLam GL19C - 230 x 60

Roof load width (mm)		1500		3000		4500		6000		7500	
Rafter/truss spacing (mm)		600	1200	600	1200	600	1200	600	1200	600	1200
Member size DxB (mm)	Roof mass (kg/m <sup>2</sup> )	Maximum recommended Verandah beam span (mm)									
		Single span									
130x60	10	3800	3800	3000	2900	2500	2400	2200	2000	1900	1700
	20	3900	3800	3100	3000	2600	2500	2200	2100	1900	1700
	40	3300	3200	2500	2600	2100	2100	1900	1900	1700	1500
	60	2900	2900	2200	2200	1900	1900	1700	1600	1500	1400
	90	2500	2600	1900	1900	1700	1600	1500	1300	1400	1200
165x60	10	4900	4900	3900	3800	3200	3100	2800	2700	2500	2400
	20	4800	4900	3900	3900	3300	3100	2800	2700	2500	2500
	40	4100	4100	3300	3200	2800	2800	2400	2500	2200	2200
	60	3700	3700	2900	2900	2500	2500	2200	2200	2000	2000
	90	3200	3200	2500	2600	2200	2100	1900	1900	1700	1700
195x60	10	5800	5800	4600	4600	3800	3600	3300	3100	2900	2800
	20	5600	5600	4500	4500	3900	3700	3400	3200	3000	2900
	40	4800	4800	3900	3900	3300	3300	2900	2900	2700	2700
	60	4300	4300	3400	3400	2900	2900	2600	2700	2400	2400
	90	3900	3800	3000	3000	2600	2600	2300	2300	2100	2100
230x60	10	6600	6600	5400	5400	4500	4500	3900	3800	3500	3300
	20	6500	6500	5200	5300	4600	4600	4000	3900	3600	3400
	40	5500	5500	4500	4500	4000	3900	3500	3500	3200	3100
	60	5000	5000	4100	4100	3500	3500	3100	3100	2800	2900
	90	4500	4500	3600	3600	3100	3100	2800	2800	2500	2500
260x60	10	7300	7300	6100	6100	5100	5100	4400	4400	4000	3800
	20	7200	7200	5900	5800	5100	5100	4500	4500	4000	3900
	40	6200	6100	5000	5000	4400	4400	4000	4000	3600	3600
	60	5600	5500	4500	4500	4000	4000	3600	3500	3300	3200
	90	5000	5000	4100	4100	3500	3500	3200	3100	2900	2900
295x60	10	8000	8000	6700	6700	5800	5700	5000	5000	4500	4500
	20	8000	8000	6600	6600	5700	5700	5100	5100	4600	4600
	40	6900	6900	5600	5600	4900	4900	4500	4400	4100	4100
	60	6200	6200	5100	5100	4500	4400	4100	4100	3700	3700
	90	5600	5600	4600	4500	4000	4000	3600	3600	3300	3300
330x60	10	8700	8700	7300	7300	6500	6400	5600	5600	5100	5000
	20	8700	8700	7300	7300	6300	6300	5700	5600	5100	5100
	40	7700	7700	6200	6200	5400	5400	4900	4900	4600	4500
	60	6900	6900	5600	5600	4900	4900	4500	4500	4200	4200
	90	6200	6200	5000	5000	4400	4400	4100	4000	3700	3700
360x60	10	9300	9300	7800	7800	7100	7000	6200	6100	5500	5500
	20	9300	9300	7800	7800	6900	6900	6100	6100	5600	5500
	40	8400	8400	6800	6700	5900	5900	5300	5300	4900	4900
	60	7500	7500	6100	6100	5300	5300	4900	4800	4500	4500
	90	6700	6700	5400	5400	4800	4800	4400	4400	4100	4100
130x75	10	4100	4100	3300	3300	2800	2700	2400	2300	2200	2100
	20	4100	4100	3300	3300	2800	2800	2400	2400	2200	2100
	40	3500	3500	2700	2800	2300	2300	2100	2000	1800	1800
	60	3100	3100	2400	2500	2100	2000	1800	1800	1600	1600
	90	2700	2700	2100	2100	1800	1800	1600	1500	1500	1300
165x75	10	5300	5300	4200	4200	3600	3400	3100	3000	2800	2700
	20	5100	5100	4200	4200	3600	3500	3100	3000	2800	2700
	40	4400	4400	3500	3500	3000	3000	2700	2700	2400	2400
	60	4000	4000	3100	3100	2700	2700	2400	2400	2100	2100
	90	3500	3500	2700	2800	2300	2300	2100	2100	1900	1900
195x75	10	6200	6200	5000	5000	4200	4200	3700	3500	3300	3200
	20	5900	5900	4800	4800	4200	4200	3800	3600	3400	3200
	40	5100	5100	4100	4100	3600	3500	3200	3100	2900	2900
	60	4600	4600	3700	3700	3200	3100	2800	2800	2600	2600
	90	4100	4100	3300	3200	2800	2800	2500	2500	2300	2300

## Single span verandah beam (Cont'd) AS 4055 classification N1, N2 and N3

Roof load width (mm)		1500		3000		4500		6000		7500	
Rafter/truss spacing (mm)		600	1200	600	1200	600	1200	600	1200	600	1200
Member size DxB (mm)	Roof mass (kg/m <sup>2</sup> )	Maximum recommended Verandah beam span (mm)									
		Single span									
230x75	10	7000	7000	5900	5800	5000	5000	4400	4300	3900	3800
	20	6800	6800	5600	5600	4900	4900	4400	4400	4000	3800
	40	5800	5800	4800	4800	4200	4200	3800	3800	3400	3400
	60	5300	5300	4300	4300	3800	3800	3400	3300	3100	3100
	90	4800	4800	3900	3900	3400	3300	3000	3000	2700	2800
260x75	10	7700	7700	6500	6500	5700	5600	5000	4900	4500	4400
	20	7600	7600	6200	6200	5400	5400	4900	4900	4500	4400
	40	6500	6500	5300	5300	4700	4700	4200	4200	3900	3900
	60	5900	5900	4800	4800	4300	4200	3900	3800	3500	3500
	90	5300	5300	4300	4300	3800	3800	3400	3400	3100	3100
295x75	10	8400	8400	7100	7100	6400	6400	5600	5600	5100	5000
	20	8400	8400	7000	7000	6100	6000	5400	5400	5000	5000
	40	7300	7300	6000	6000	5200	5200	4800	4700	4400	4400
	60	6600	6600	5400	5400	4800	4700	4300	4300	4000	4000
	90	6000	5900	4900	4800	4300	4300	3900	3900	3600	3500
330x75	10	9200	9200	7700	7700	7000	7000	6300	6200	5700	5600
	20	9200	9200	7700	7700	6700	6700	6000	6000	5500	5500
	40	8200	8200	6600	6600	5800	5800	5200	5300	4800	4800
	60	7400	7400	6000	6000	5300	5300	4800	4800	4400	4400
	90	6600	6600	5400	5400	4700	4700	4300	4300	4000	4000
360x75	10	9800	9800	8300	8300	7500	7500	6900	6900	6200	6100
	20	9800	9800	8200	8200	7300	7300	6500	6500	6000	6000
	40	8900	8900	7200	7200	6300	6300	5700	5700	5200	5200
	60	8000	8000	6500	6500	5700	5700	5200	5200	4800	4800
	90	7200	7200	5800	5800	5100	5100	4700	4600	4300	4300

## Continuous span verandah beam AS 4055 classification N1, N2 and N3

Roof load width (mm)		1500		3000		4500		6000		7500	
Rafter/truss spacing (mm)		600	1200	600	1200	600	1200	600	1200	600	1200
Member size DxB (mm)	Roof mass (kg/m <sup>2</sup> )	Maximum recommended Verandah beam span (mm)									
		Continuous span									
130x60	10	4400	4300	3100	3100	2500	2600	2200	2100	2000	1900
	20	4500	4400	3200	3100	2600	2700	2200	2200	2000	1900
	40	4000	4000	3100	3100	2500	2600	2100	2000	1900	1900
	60	3600	3600	2800	2800	2300	2300	2000	1900	1700	1700
	90	3200	3100	2500	2500	2100	2100	1800	1800	1600	1500
165x60	10	5600	5600	3900	3900	3200	3200	2800	2800	2500	2600
	20	5500	5500	4000	4000	3300	3200	2900	2900	2600	2600
	40	4800	4800	3900	3900	3200	3100	2700	2700	2400	2400
	60	4400	4400	3600	3600	3000	3000	2600	2600	2300	2200
	90	4000	4000	3200	3100	2800	2700	2400	2400	2100	2000
195x60	10	6600	6600	4700	4600	3800	3800	3300	3300	3000	3000
	20	6100	6100	4800	4800	3900	3900	3400	3300	3000	3000
	40	5400	5400	4600	4500	3800	3700	3200	3200	2800	2800
	60	5000	5000	4200	4200	3500	3500	3000	3000	2700	2700
	90	4500	4500	3800	3700	3300	3200	2800	2800	2500	2600
230x60	10	7400	7600	5500	5500	4500	4500	3900	3900	3500	3400
	20	6800	6900	5600	5600	4600	4600	4000	4000	3600	3500
	40	6100	6100	5100	5200	4400	4400	3800	3700	3400	3300
	60	5600	5600	4700	4700	4200	4200	3600	3500	3200	3200
	90	5100	5200	4300	4300	3900	3800	3400	3300	3000	3000
260x60	10	7900	8200	6200	6200	5100	5200	4400	4400	4000	4000
	20	7300	7500	6400	6400	5200	5200	4600	4500	4000	4000
	40	6600	6600	5600	5600	5000	5000	4300	4300	3800	3800
	60	6100	6100	5200	5200	4700	4600	4100	4100	3600	3500
	90	5600	5600	4700	4700	4300	4200	3800	3700	3400	3300
295x60	10	8500	8900	7100	7100	5800	5800	5100	5100	4500	4500
	20	7800	8200	6900	7000	6000	5900	5200	5200	4600	4500
	40	7100	7200	6200	6200	5500	5500	4900	4900	4300	4300
	60	6600	6700	5700	5700	5100	5100	4600	4600	4100 <sub>5</sub>	4100 <sub>5</sub>
	90	6200	6100	5200	5200	4700	4700	4300	4300	3800 <sub>10</sub>	3800 <sub>10</sub>

## Continuous span verandah beam (Cont'd) AS 4055 classification N1, N2 and N3

Roof load width (mm)		1500		3000		4500		6000		7500	
Rafter/truss spacing (mm)		600	1200	600	1200	600	1200	600	1200	600	1200
Member size DxB (mm)	Roof mass (kg/m <sup>2</sup> )	Maximum recommended Verandah beam span (mm)									
		Continuous span									
330x60	10	9100	9500	8000	7900	6500	6500	5700	5600	5100	5100
	20	8400	8800	7400	7500	6700	6700	5800	5800	5100 <sub>5</sub>	5200 <sub>5</sub>
	40	7600	7800	6600	6700	6000	6000	5400	5400	4800 <sub>10</sub>	4800 <sub>10</sub>
	60	7100	7200	6200	6200	5500	5600	5100 <sub>5</sub>	5100 <sub>5</sub>	4600 <sub>15</sub>	4500 <sub>15</sub>
	90	6600	6700	5700	5700	5100	5100	4700 <sub>10</sub>	4700 <sub>10</sub>	4300 <sub>20</sub>	4300 <sub>20</sub>
360x60	10	9500	10100	8400	8700	7100	7100	6200	6100	5600 <sub>5</sub>	5500 <sub>5</sub>
	20	8800	9300	7700	8000	7100	7200	6300 <sub>5</sub>	6300	5600 <sub>10</sub>	5600 <sub>10</sub>
	40	8000	8400	7000	7100	6400	6400	5900 <sub>5</sub>	5900 <sub>5</sub>	5300 <sub>20</sub>	5300 <sub>20</sub>
	60	7500	7700	6500	6600	5900	5900	5500 <sub>10</sub>	5500 <sub>10</sub>	5000 <sub>20</sub>	5000 <sub>20</sub>
	90	7000	7100	6000	6100	5400	5400	5000 <sub>15</sub>	5000 <sub>15</sub>	4700 <sub>30</sub>	4600 <sub>30</sub>
130x75	10	4900	5000	3500	3400	2800	2800	2500	2600	2200	2100
	20	4800	4900	3500	3500	2900	2900	2500	2600	2200	2200
	40	4200	4200	3400	3400	2800	2800	2400	2500	2100	2000
	60	3800	3800	3000	3000	2600	2600	2200	2200	2000	1900
	90	3400	3400	2700	2700	2300	2300	2100	2000	1800	1800
165x75	10	6300	6200	4400	4400	3600	3500	3100	3100	2800	2800
	20	5700	5700	4500	4500	3700	3600	3200	3200	2900	2900
	40	5000	5100	4200	4200	3500	3500	3000	3000	2700	2700
	60	4600	4600	3900	3900	3300	3300	2900	2900	2600	2600
	90	4200	4200	3400	3400	3000	3000	2700	2700	2300	2300
195x75	10	6900	7000	5200	5200	4300	4300	3700	3600	3400	3300
	20	6400	6400	5300	5400	4400	4400	3800	3800	3400	3300
	40	5700	5700	4800	4800	4200	4200	3600	3500	3200	3200
	60	5200	5200	4400	4400	4000	3900	3400	3300	3000	3000
	90	4800	4800	4000	4000	3500	3500	3200	3100	2800	2800
230x75	10	7600	7800	6200	6100	5100	5100	4400	4400	4000	3900
	20	7000	7100	6100	6100	5200	5200	4500	4500	4000	4000
	40	6400	6400	5400	5400	4900	4900	4200	4200	3800	3700
	60	5900	5900	5000	5000	4500	4500	4000	4000	3600	3500
	90	5400	5400	4600	4600	4100	4100	3700	3700	3300	3300
260x75	10	8200	8500	7000	7000	5700	5700	5000	5000	4500	4400
	20	7500	7800	6600	6700	5900	5800	5100	5100	4500	4500
	40	6900	6900	5900	5900	5300	5300	4800	4800	4200	4200
	60	6400	6400	5500	5500	4900	4900	4500	4500	4000	4000
	90	5900	5900	5000	5000	4500	4500	4200	4200	3800	3700
295x75	10	8800	9200	7700	8000	6500	6500	5700	5600	5100	5100
	20	8100	8500	7100	7300	6500	6600	5800	5700	5100	5200
	40	7400	7600	6500	6500	5800	5800	5400	5400	4800	4800
	60	6900	7000	6000	6000	5400	5400	5000	5000	4600	4500
	90	6400	6400	5500	5500	4900	4900	4600	4600	4300	4300
330x75	10	9300	9800	8200	8600	7300	7300	6300	6300	5700	5700
	20	8600	9100	7600	7900	7000	7100	6500	6500	5700	5700
	40	7900	8200	6900	7000	6300	6300	5900	5900	5400	5400
	60	7400	7600	6500	6500	5900	5900	5400	5400	5100 <sub>5</sub>	5100 <sub>5</sub>
	90	6900	7000	6000	6000	5400	5400	5000	5000	4700 <sub>10</sub>	4700 <sub>10</sub>
360x75	10	9800	10300	8700	9100	7900	8000	6900	6900	6200	6200
	20	9100	9600	8000	8400	7400	7500	6900	6900	6300 <sub>5</sub>	6200 <sub>5</sub>
	40	8300	8700	7300	7400	6700	6700	6200	6200	5900 <sub>10</sub>	5800 <sub>10</sub>
	60	7800	8100	6800	6900	6200	6200	5800	5800	5400 <sub>10</sub>	5400 <sub>10</sub>
	90	7300	7400	6300	6300	5700	5700	5300	5300	5000 <sub>15</sub>	5000 <sub>15</sub>

### NOTES:

1. D = member depth, B = member breadth, NS = not suitable.
2. End bearing lengths = 70 mm at end supports and 70 mm at internal supports for continuous members. Subscript values indicate the minimum additional bearing length where required to be greater than 70 mm at end supports and 70 mm at internal supports.
3. Restraint value for slenderness calculations is 1200 mm
4. Not all sizes of SmartLam GL19C in this table are stocked in each state. Please check with your supplier before ordering



# Single span verandah beam AS 4055 classification C1, C2 and C3

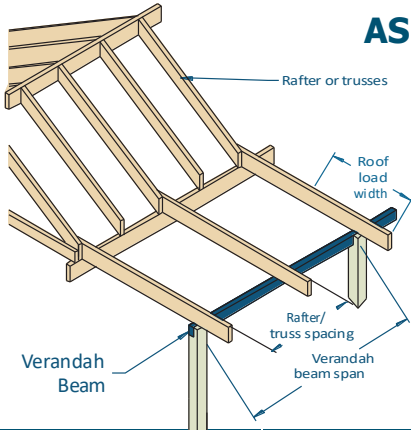

### EXAMPLE:

wind speed = C3  
sheet roof - 40 kg/m<sup>2</sup>  
rafter/truss spacing = 600 mm  
verandah span = 3500 mm (single span)  
roof load width = 3900 mm

Enter span table at 4500 roof load width column, rafter spacing of 600 mm, and read down to a span equal to or greater than 3500 mm at 40 kg/m<sup>2</sup> row

### ADOPT:

SmartLam GL19C - 295x 60

Roof load width (mm)		1500		3000		4500		6000		7500	
Rafter/truss spacing (mm)		600	1200	600	1200	600	1200	600	1200	600	1200
Member size DxB (mm)	Roof mass (kg/m <sup>2</sup> )	Maximum recommended Verandah span (mm)									
		Single span									
130x60	10	2800	2800	2000	1800	1600	1200	1400	NS	1200	NS
	20	2900	2800	2000	1800	1600	1200	1400	NS	1200	NS
	40	2900	2800	2000	1900	1600	1200	1400	NS	1300	NS
	60	2900	2900	2100	2000	1600	1300	1400	1000	1300	NS
	90	2500	2600	1900	1900	1600	1200	1400	NS	1200	NS
165x60	10	3700	3500	2600	2500	2100	1900	1700	1400	1500	1100
	20	3700	3500	2600	2500	2100	1900	1800	1500	1600	1200
	40	3800	3600	2600	2600	2100	2000	1800	1500	1600	1200
	60	3700	3700	2700	2600	2200	2100	1800	1600	1600	1300
	90	3200	3200	2500	2600	2100	2000	1800	1500	1600	1200
195x60	10	4300	4300	3000	2900	2500	2400	2100	2000	1900	1600
	20	4400	4300	3100	2900	2500	2400	2200	2000	1900	1600
	40	4500	4400	3100	3000	2600	2500	2200	2100	1900	1700
	60	4300	4300	3200	3100	2600	2500	2300	2100	2000	1800
	90	3900	3800	3000	3000	2500	2400	2200	2100	1900	1600
230x60	10	5100	5100	3600	3400	2900	2800	2500	2400	2300	2200
	20	5200	5100	3700	3500	2900	2800	2600	2500	2300	2200
	40	5200	5200	3700	3600	3000	2900	2600	2500	2400	2200
	60	5000	5000	3800	3600	3100	3000	2700	2600	2400	2300
	90	4500	4500	3600	3500	3000	2900	2600	2500	2300	2200
260x60	10	5800	5700	4100	4000	3300	3200	2900	2800	2600	2500
	20	5900	5800	4100	4000	3400	3200	2900	2800	2600	2500
	40	5900	5900	4200	4100	3400	3300	2900	2800	2600	2600
	60	5600	5500	4300	4200	3500	3300	3000	2900	2700	2600
	90	5000	5000	4100	4100	3400	3200	2900	2800	2600	2500
295x60	10	6600	6500	4700	4600	3800	3600	3300	3100	2900	2800
	20	6600	6600	4700	4700	3800	3700	3300	3200	2900	2800
	40	6600	6600	4800	4800	3900	3800	3400	3200	3000	2900
	60	6200	6200	4900	4900	4000	3900	3500	3300	3100	3000
	90	5600	5600	4600	4500	3900	3700	3300	3200	2900	2800
330x60	10	7100	7100	5200	5200	4200	4200	3700	3500	3300	3100
	20	7100	7100	5300	5200	4300	4200	3700	3600	3300	3200
	40	7200	7100	5400	5300	4400	4300	3800	3600	3400	3200
	60	6900	6900	5500	5400	4500	4400	3900	3700	3500	3300
	90	6200	6200	5000	5000	4300	4300	3700	3600	3300	3200
360x60	10	7600	7600	5700	5600	4600	4600	4000	3900	3600	3400
	20	7600	7600	5700	5700	4700	4700	4000	3900	3600	3500
	40	7600	7600	5900	5800	4800	4800	4100	4000	3700	3500
	60	7500	7500	6000	5900	4900	4900	4200	4100	3800	3600
	90	6700	6700	5400	5400	4700	4700	4100	3900	3600	3500
130x75	10	3200	3100	2300	2100	1800	1500	1500	1100	1400	NS
	20	3200	3100	2300	2100	1800	1500	1500	1100	1400	NS
	40	3200	3200	2300	2200	1800	1600	1600	1200	1400	NS
	60	3100	3100	2400	2300	1900	1600	1600	1200	1400	1000
	90	2700	2700	2100	2100	1800	1500	1500	1100	1400	NS
165x75	10	4100	4000	2900	2800	2400	2200	2000	1800	1700	1400
	20	4000	4000	2900	2800	2400	2200	2000	1800	1800	1500
	40	4000	4000	2900	2800	2400	2300	2100	1900	1800	1500
	60	4000	4000	3000	2900	2500	2400	2100	2000	1800	1600
	90	3500	3500	2700	2800	2300	2300	2000	1900	1800	1500
195x75	10	4800	4800	3400	3300	2800	2700	2400	2300	2100	2000
	20	4800	4800	3500	3300	2800	2700	2400	2300	2200	2100
	40	4800	4800	3600	3400	2800	2800	2500	2400	2200	2100
	60	4600	4600	3600	3400	2900	2800	2500	2400	2300	2200
	90	4100	4100	3300	3200	2800	2700	2500	2300	2200	2100

## Single span verandah beam (Cont'd) AS 4055 classification C1, C2 and C3

Roof load width (mm)		1500		3000		4500		6000		7500	
Rafter/truss spacing (mm)		600	1200	600	1200	600	1200	600	1200	600	1200
Member size DxB (mm)	Roof mass (kg/m <sup>2</sup> )	Maximum recommended Verandah beam span (mm)									
		Continuous span									
230x75	10	5600	5600	4000	3900	3300	3100	2800	2700	2500	2400
	20	5600	5600	4100	4000	3300	3200	2900	2800	2600	2500
	40	5600	5600	4200	4100	3400	3200	2900	2800	2600	2500
	60	5300	5300	4300	4200	3500	3300	3000	2900	2700	2600
	90	4800	4800	3900	3900	3400	3200	2900	2800	2600	2500
260x75	10	6300	6300	4600	4600	3700	3600	3200	3100	2900	2800
	20	6300	6300	4600	4600	3800	3600	3300	3100	2900	2800
	40	6300	6300	4700	4700	3900	3700	3300	3200	3000	2900
	60	5900	5900	4800	4800	3900	3800	3400	3200	3000	2900
	90	5300	5300	4300	4300	3800	3700	3300	3100	2900	2800
295x75	10	6900	6900	5200	5200	4200	4200	3700	3500	3300	3100
	20	6900	6900	5300	5200	4300	4200	3700	3600	3300	3200
	40	6900	6900	5400	5300	4400	4300	3800	3600	3400	3200
	60	6600	6600	5400	5400	4500	4400	3900	3700	3500	3300
	90	6000	5900	4900	4800	4300	4200	3700	3600	3300	3200
330x75	10	7500	7600	5800	5700	4800	4700	4100	4000	3700	3500
	20	7600	7600	5900	5800	4800	4800	4200	4000	3700	3600
	40	7500	7600	6000	5900	4900	4900	4200	4200	3800	3600
	60	7400	7400	6000	6000	5000	5000	4300	4300	3900	3700
	90	6600	6600	5400	5400	4700	4700	4200	4100	3700	3600
360x75	10	8000	8100	6400	6300	5200	5100	4500	4500	4000	3900
	20	8100	8100	6400	6400	5200	5200	4600	4500	4100	3900
	40	8000	8100	6600	6500	5400	5300	4700	4600	4100	4000
	60	8000	8000	6500	6500	5500	5400	4800	4700	4200	4100
	90	7200	7200	5800	5800	5100	5100	4600	4500	4000	3900

## Continuous span verandah beam AS 4055 classification C1, C2 and C3

Roof load width (mm)		1500		3000		4500		6000		7500	
Rafter/truss spacing (mm)		600	1200	600	1200	600	1200	600	1200	600	1200
Member size DxB (mm)	Roof mass (kg/m <sup>2</sup> )	Maximum recommended Verandah beam span (mm)									
		Continuous span									
130x60	10	2900	2900	2000	1900	1600	1500	1400	1100	1100	NS
	20	2900	2900	2000	2000	1600	1500	1400	1200	1300	NS
	40	3000	2900	2100	2000	1700	1500	1500	1200	1300	NS
	60	3000	3000	2100	2000	1700	1700	1500	1300	1400	NS
	90	3000	3000	2100	2000	1700	1500	1400	1200	1300	NS
165x60	10	3700	3600	2600	2700	2100	2000	1800	1600	1600	1300
	20	3700	3600	2600	2700	2100	2000	1800	1600	1600	1300
	40	3800	3700	2700	2700	2200	2100	1900	1600	1600	1400
	60	3900	3800	2700	2800	2200	2100	1900	1700	1600	1400
	90	3800	3700	2700	2700	2200	2100	1800	1600	1600	1300
195x60	10	4400	4300	3100	3000	2500	2600	2200	2000	1700	1500
	20	4400	4400	3100	3100	2500	2600	2200	2100	1800	1600
	40	4500	4400	3200	3100	2600	2600	2200	2100	2000	1600
	60	4600	4500	3200	3200	2600	2700	2300	2200	2000	1700
	90	4500	4400	3200	3100	2600	2600	2200	2100	1800	1600
230x60	10	5200	5200	3600	3500	2900	2900	2600	2600	2300	2200
	20	5200	5200	3700	3600	3000	3000	2600	2700	2300	1800
	40	5300	5300	3700	3700	3000	3000	2600	2700	2300	1800
	60	5400	5400	3800	3800	3100	3100	2700	2700	2400 <sub>5</sub>	2400 <sub>5</sub>
	90	5100	5200	3700	3600	3000	3000	2600	2700 <sub>5</sub>	2300 <sub>10</sub>	1800
260x60	10	5800	5800	4100	4100	3400	3300	2900	2900	2500	2700
	20	5900	5800	4100	4100	3400	3300	2900	2900	2600	2700 <sub>5</sub>
	40	6000	6000	4200	4200	3500	3400	3000	3000	2700 <sub>10</sub>	2700 <sub>15</sub>
	60	6100	6100	4300	4300	3500	3500	3100 <sub>10</sub>	3000 <sub>10</sub>	2700 <sub>20</sub>	2800 <sub>20</sub>
	90	5600	5600	4200	4200	3400	3300	2900 <sub>10</sub>	2900 <sub>15</sub>	2600 <sub>20</sub>	2700 <sub>25</sub>
295x60	10	6600	6600	4700	4600	3800	3700	3300	3200	2900 <sub>10</sub>	2900 <sub>10</sub>
	20	6700	6700	4700	4700	3900	3800	3300 <sub>5</sub>	3200	3000 <sub>15</sub>	3000 <sub>15</sub>
	40	6800	6800	4800	4800	3900	3900	3400 <sub>10</sub>	3300 <sub>10</sub>	3000 <sub>20</sub>	3000 <sub>20</sub>
	60	6600	6700	4900	4900	4000 <sub>5</sub>	4000 <sub>5</sub>	3500 <sub>20</sub>	3400 <sub>15</sub>	3100 <sub>30</sub>	3100 <sub>30</sub>
	90	6200	6100	4800	4700	3900 <sub>10</sub>	3800 <sub>10</sub>	3400 <sub>25</sub>	3300 <sub>20</sub>	3000 <sub>35</sub>	3000 <sub>35</sub>

## Continuous span verandah beam (Cont'd) AS 4055 classification C1, C2 and C3

Roof load width (mm)		1500		3000		4500		6000		7500	
Rafter/truss spacing (mm)		600	1200	600	1200	600	1200	600	1200	600	1200
Member size DxB (mm)	Roof mass (kg/m <sup>2</sup> )	Maximum recommended Verandah beam span (mm)									
		Continuous span									
330x60	10	7400	7400	5200	5200	4300	4300	3700 <sub>10</sub>	3600 <sub>5</sub>	3300 <sub>20</sub>	3300 <sub>20</sub>
	20	7500	7500	5300	5300	4300	4300	3700 <sub>15</sub>	3700 <sub>10</sub>	3400 <sub>25</sub>	3300 <sub>20</sub>
	40	7600	7700	5400	5400	4400 <sub>5</sub>	4400 <sub>5</sub>	3800 <sub>20</sub>	3800 <sub>20</sub>	3400 <sub>35</sub>	3000 <sub>20</sub>
	60	7100	7200	5500	5500	4500 <sub>15</sub>	4500 <sub>15</sub>	3900 <sub>30</sub>	3900 <sub>30</sub>	3500 <sub>40</sub>	3400 <sub>40</sub>
	90	6600	6700	5300	5300	4300 <sub>20</sub>	4300 <sub>20</sub>	3700 <sub>35</sub>	3700 <sub>35</sub>	3300 <sub>50</sub>	3300 <sub>45</sub>
360x60	10	8100	8100	5700	5700	4700 <sub>5</sub>	4600 <sub>5</sub>	4000 <sub>15</sub>	4000 <sub>15</sub>	3600 <sub>30</sub>	3400 <sub>25</sub>
	20	8200	8200	5800	5700	4700 <sub>5</sub>	4600 <sub>10</sub>	4100 <sub>20</sub>	4100 <sub>20</sub>	3700 <sub>35</sub>	3400 <sub>25</sub>
	40	8000	8300	5900	5800	4800 <sub>15</sub>	4700 <sub>15</sub>	4200 <sub>30</sub>	4200 <sub>30</sub>	3700 <sub>45</sub>	3400 <sub>35</sub>
	60	7500	7700	6000 <sub>5</sub>	6000 <sub>5</sub>	4900 <sub>25</sub>	4900 <sub>25</sub>	4200 <sub>40</sub>	4200 <sub>40</sub>	3800 <sub>55</sub>	3700 <sub>55</sub>
	90	7000	7100	5800 <sub>10</sub>	5800 <sub>10</sub>	4800 <sub>30</sub>	4700 <sub>25</sub>	4100 <sub>45</sub>	4100 <sub>45</sub>	3700 <sub>65</sub>	3400 <sub>50</sub>
130x75	10	3200	3200	2200	2200	1800	1800	1600	1400	1400	1200
	20	3300	3200	2300	2300	1800	1800	1600	1500	1400	1200
	40	3300	3300	2300	2300	1900	1900	1600	1500	1500	1200
	60	3400	3300	2400	2500	2000	1900	1600	1500	1500	1300
	90	3300	3300	2300	2300	1900	1900	1600	1500	1400	1200
165x75	10	4100	4100	2900	2900	2300	2300	2000	2000	1800	1600
	20	4200	4100	2900	2900	2400	2400	2100	2000	1800	1600
	40	4200	4200	3000	3000	2400	2600	2100	2000	1900	1600
	60	4300	4300	3000	3000	2500	2600	2200	2000	1900	1600
	90	4200	4200	3000	3000	2400	2400	2100	2000	1800	1600
195x75	10	4900	4900	3400	3400	2800	2800	2400	2400	2200	2100
	20	4900	5000	3500	3400	2800	2800	2400	2400	2200	2100
	40	5000	5100	3500	3500	2900	2900	2500	2600	2200	2100
	60	5100	5200	3600	3500	2900	2900	2600	2600	2300	2200
	90	4800	4800	3500	3400	2900	2900	2500	2600	2200	2100
230x75	10	5800	5700	4100	4000	3300	3300	2900	2900	2600	2600
	20	5800	5800	4100	4100	3400	3300	2900	2900	2600	2700
	40	5900	5900	4200	4200	3400	3300	2900	2900	2700	2700
	60	5900	5900	4300	4300	3500	3400	3000	3000	2700	2700
	90	5400	5400	4100	4100	3400	3300	2900	2900	2600	2700 <sub>5</sub>
260x75	10	6500	6500	4600	4500	3800	3700	3300	3200	2900	2900
	20	6600	6600	4700	4600	3800	3700	3300	3200	2900	2900
	40	6700	6700	4700	4700	3900	3800	3400	3300	3000	3000
	60	6400	6400	4800	4800	4000	4000	3500	3400	3100 <sub>10</sub>	3000 <sub>10</sub>
	90	5900	5900	4700	4600	3800	3800	3300	3200	2900 <sub>10</sub>	2900 <sub>10</sub>
295x75	10	7400	7400	5200	5200	4300	4300	3700	3600	3300	3200
	20	7500	7500	5300	5300	4300	4300	3700	3700	3400 <sub>5</sub>	3300
	40	7400	7600	5400	5400	4400	4400	3800	3800	3400 <sub>10</sub>	3300 <sub>10</sub>
	60	6900	7000	5500	5500	4500	4500	3900 <sub>10</sub>	3900 <sub>10</sub>	3500 <sub>20</sub>	3400 <sub>15</sub>
	90	6400	6400	5300	5300	4300	4300	3700 <sub>10</sub>	3700 <sub>10</sub>	3300 <sub>20</sub>	3200 <sub>20</sub>
330x75	10	8300	8300	5900	5800	4800	4700	4100	4100	3700 <sub>10</sub>	3600 <sub>10</sub>
	20	8400	8400	5900	5900	4800	4800	4200 <sub>5</sub>	4200 <sub>5</sub>	3700 <sub>15</sub>	3700 <sub>15</sub>
	40	7900	8200	6000	6000	4900	4900	4300 <sub>10</sub>	4300 <sub>10</sub>	3800 <sub>20</sub>	3800 <sub>20</sub>
	60	7400	7600	6200	6100	5000 <sub>5</sub>	5000 <sub>5</sub>	4400 <sub>20</sub>	4400 <sub>20</sub>	3900 <sub>30</sub>	3900 <sub>30</sub>
	90	6900	7000	6000	5900	4900 <sub>10</sub>	4800 <sub>10</sub>	4200 <sub>25</sub>	4200 <sub>25</sub>	3700 <sub>35</sub>	3700 <sub>35</sub>
360x75	10	9100	9100	6400	6400	5200	5200	4500 <sub>5</sub>	4500 <sub>5</sub>	4000 <sub>20</sub>	4000 <sub>15</sub>
	20	9100	9200	6500	6400	5300	5300	4600 <sub>10</sub>	4500 <sub>10</sub>	4100 <sub>20</sub>	4100 <sub>25</sub>
	40	8300	8700	6600	6600	5400 <sub>5</sub>	5400 <sub>5</sub>	4700 <sub>20</sub>	4600 <sub>20</sub>	4200 <sub>30</sub>	4200 <sub>30</sub>
	60	7800	8100	6700	6700	5500 <sub>15</sub>	5500 <sub>15</sub>	4800 <sub>25</sub>	4700 <sub>25</sub>	4200 <sub>40</sub>	4200 <sub>40</sub>
	90	7300	7400	6300	6300	5300 <sub>15</sub>	5300 <sub>15</sub>	4600 <sub>30</sub>	4500 <sub>30</sub>	4100 <sub>45</sub>	4100 <sub>45</sub>

### NOTES:

- D = member depth, B = member breadth, NS = not suitable.
- End bearing lengths = 70mm at end supports and 70 mm at internal supports for continuous members. Subscript values indicate the minimum additional bearing length where required to be greater than 70 mm at end supports and 70 mm at internal supports.
- Restraint value for slenderness calculations is 1200 mm
- Not all sizes of SmartLam GL19C in this table are stocked in each state. Please check with your supplier before ordering

## Hip rafter - sheet and tile roof AS 4055 wind classification N1, N2, N3, C1, C2 & C3

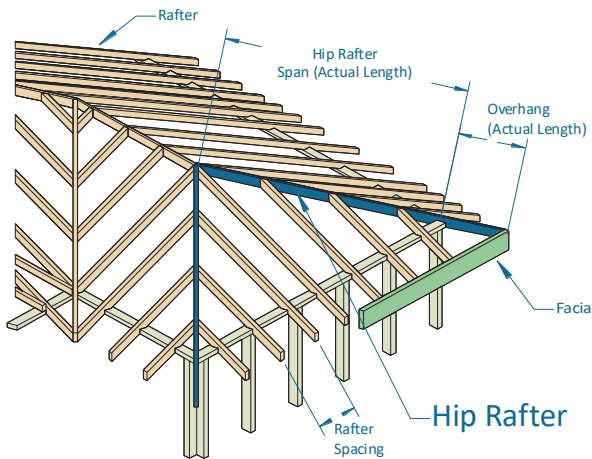

### EXAMPLE:

wind speed = N3  
 roof load = 40 kg/m<sup>2</sup> (sheet roof)  
 hip rafter span = 4500 mm (single span)  
 rafter spacing = 600 mm

Enter column at (N1,N2 & N3) wind speed, 600 mm rafter spacing and read down to span equal to or greater than 4500 mm for a 40 kg/m<sup>2</sup> roof load

### ADOPT:

**SmartLam GL19C — 195x60**

Wind Speed		N1, N2 & N3				C1, C2 & C3			
Rafter spacing (mm)		600		1200		600		1200	
		Maximum Rafter span + overhang span (mm)							
Member size DxB (mm)	Roof & ceiling mass (kg/m <sup>2</sup> )	Span	Overhang	Span	Overhang	Span	Overhang	Span	Overhang
		Single span				Single span			
130x60	40	3700	800	3700	800	3400	800	3400	800
	90	3000	800	3000	750	3000	800	3000	750
165x60	40	4400	1100	4400	1050	3900	1100	3900	1050
	90	3700	1000	3700	1000	3700	1000	3700	1000
195x60	40	5000	1400	5000	1350	4400	1400	4400	1350
	90	4200	1250	4200	1250	4200	1250	4200	1250
230x60	40	5700	1650	5700	1650	4900	1650	4900	1650
	90	4800	1500	4800	1500	4800	1500	4800	1500
260x60	40	6200	1900	6200	1900	5300	1800	5400	1800
	90	5200	1700	5200	1700	5200	1700	5200	1700
295x60	40	6700	2200	6700	2150	5800	1900	5800	1900
	90	5800	1900	5800	1900	5700	1850	5800	1800
330x60	40	7200	2450	7200	2400	6300	2050	6300	2050
	90	6300	2100	6300	2100	6200	1950	6200	1950
360x60	40	7600	2600	7700	2600	6700	2150	6700	2100
	90	6600	2250	6600	2250	660 <sub>05</sub>	2000	6600 <sub>5</sub>	2000
130x75	40	3800	1000	3800	1000	3600	1000	3600	1000
	90	3200	950	3200	950	3200	950	3200	950
165x75	40	4600	1300	4600	1300	4300	1300	4200	1300
	90	3900	1200	3900	1200	3900	1200	3900	1200
195x75	40	5300	1650	5300	1600	4800	1650	4800	1600
	90	4400	1500	4400	1450	4400	1500	4400	1450
230x75	40	6000	1950	6000	1950	5300	1800	5300	1800
	90	5000	1750	5000	1750	5000	1750	5000	1750
260x75	40	6500	2200	6500	2200	5800	1950	5800	1950
	90	5500	1950	5500	1950	5500	1850	5500	1850
295x75	40	7000	2500	7000	2450	6300	2100	6300	2050
	90	6100	2200	6100	2150	6100	1950	6100	1950
330x75	40	7500	2750	7600	2700	6800	2200	6800	2200
	90	6600	2400	6600	2350	6600	2100	6600	2100
360x75	40	8000	2900	8000	2850	7200	2300	7200	2300
	90	7000	2550	7000	2550	7000	2200	7000	2200

### NOTES:

- D = member depth, B = member breadth, NS = not suitable.
- The above table was based on a batten spacing of 900 mm
- Minimum backspan = 200% of overhang
- Maximum birds mouth depth = 30% of depth
- End bearing length = 35 at end supports and 35 mm. Subscript values indicate the minimum additional bearing length where required to be greater than 35 mm at end support
- Construction loads shall not be applied to overhangs until a 190 x 19 mm (min) timber fascia or other fascia of equivalent stiffness is rigidly and permanently attached to the end of rafter overhangs
- Not all sizes of SmartLam GL19C in this table are stocked in each state. Please check with your supplier before ordering





# SMARTFRAME<sup>®</sup>

POWERED BY INNOVATION



## Head Office

### Victoria

31-45 Orchard Street  
Kilsyth Vic 3137

email: [sales@tilling.com.au](mailto:sales@tilling.com.au)

Phone +61 3 9725 0222

Fax +61 3 9725 3045

### New South Wales

109 Kurrajong Avenue  
Mt Druitt, NSW 2770

email: [nswsales@tilling.com.au](mailto:nswsales@tilling.com.au)

Phone +61 2 9677 2600

Fax +61 2 9677 2500

### Queensland

84 Magnesium Drive  
Crestmead QLD 4132

email: [qldsales@tilling.com.au](mailto:qldsales@tilling.com.au)

Phone +61 7 3440 5400

Fax +61 7 3440 5444

### Western Australia

10 Cartwright Drive  
Forrestdale WA 6112

email: [wasales@tilling.com.au](mailto:wasales@tilling.com.au)

Phone +61 8 9399 1609

Fax +61 8 9399 1065

### South Australia

5-9 Woomera Ave  
Edinburgh SA 5111

email: [sasales@tilling.com.au](mailto:sasales@tilling.com.au)

Phone +61 8 8345 1966

Fax +61 8 8345 1977

**Sales 1800 33 77 03**

**Technical support 1300 668 690**

