

# SmartLam GLT15S

(Straight)

## Design Guide



## Table of Contents

Introduction	2
Ordering SmartLam GLT15S	2
Installation	
- Preparatory work	2
- Deflection	2
- Verticality	2
- Holes for services	2
- Notches	3
- Birdsmouthing	4
- Eaves overhang	4
- Steel post and timber fixing	4
Multiple SmartLam GLT15S section beams	
- Type 17 screw	5
- bolts	5
Durability and weather exposed application	6
Protection systems	
- During construction	6
- Moisture effects	7
- Dimensional change	7
- Strength change	7
- Design for durability	7
- Preservative treatment	8
- Painted SmartLam GLT15S	8
- Covered alfresco beams	9
- H3 Deck bearers and joists	9
Fire rating (resistance)	9
Designing with SmartLam GLT15S	
- Product specification	10
- Limit state design characteristic	10
- Strength reduction factors	10
- Duration of load	10
- Partial seasoning factor	10
- Length and position of bearing	10
- Load sharing	10
- Stability	10
- Temperature	10
Beam section properties	11
Design/Effective span	13
Checking of SmartLam GLT15S	13
Storage and handling	13
List of table and charts	15
Span tables	16-49

## Scope of this publication

This Design Guide and Load Tables assist in the selection of SmartLam GLT15S for some of the common structural arrangements met in domestic construction.

Other than the limited examples uniquely associated with GLT shown, methods of developing lateral restraint and providing adequate support, adequate anchorage against wind uplift, and overall structural stability are outside the scope of this publication.

Information on the above matters can be obtained from AS 1684 Residential timber-framed construction or from a structural engineer experienced in timber construction.

Tilling Timber Pty Ltd have structural engineers within the SmartFrame Design Centre who can be contacted for advice on matters concerning the use of its SmartFrame engineered timber products in timber construction via the technical support Helpline on 1300 668 690 or e-mail at techsupport@tilling.com.au

### Substitution of other products

All load tables in this document are designed using the unique characteristic properties of SmartLam GLT15S manufactured to AS/NZS 1328 by quality producers 3<sup>rd</sup> party audited by the GLTAA, and distributed by Tilling Timber Pty Ltd.

### Copyright

Copyright of this publication remains the property of Tilling Timber Pty Ltd, and reproduction of the whole or part of this publication without written permission from Tilling Timber Pty Ltd is prohibited.

### Certification

As a professional engineer, qualified and experienced in timber engineering, I certify that the use of the SmartLam GLT15S members as shown in these tables, and installed in accordance with the provisions of this Design Guide, complies to the Building Code of Australia. These Span Tables have been prepared in accordance with standard engineering principles, the relevant test reports and Australian standards, ie:

- AS 1720.3 Timber structures Part 3: Design criteria for timber framed residential buildings
- AS 1720.1 Timber structures - design methods
- AS 4055 Wind loads for houses
- AS/NZS 4063 Characterisation of structural timber
- AS/NZS 1328 Glue laminated structural timber - performance requirements and minimum production requirements.

### SmartFrame Product Warranty\*

Tilling Timber warrants that its SmartFrame Engineered Wood products will be free from manufacturing defects in workmanship and material.

In addition, provided the product is correctly installed and used, Tilling Timber warrants the adequacy of its design for the normal and expected life of the structure.

This warranty is backed by the full resources of Tilling Timber and by under-written product liability insurance.

Tilling Timber Pty Ltd  
31-45 Orchard Street  
Kilsyth Vic 3137

Ph: +61 (0)3 9725 0222 Fax: +61 (0)3 9725 6569

Email: techsupport@tilling.com.au

*Craig Kay*

CRAIG KAY RPEng(Civil), BDC0730,  
PE0001869, RPEQ 5100, CC5635C, NER  
National Product Engineer

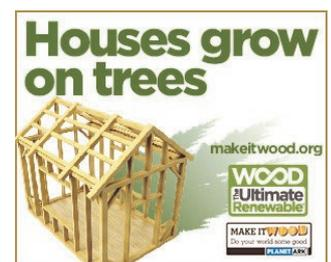

The information contained in this product brochure is current as at August 2022 and is based on data available to Tilling Timber Pty Ltd at the time of going to print. Tilling Timber Pty Ltd has used its reasonable endeavours to ensure the accuracy and reliability of the information contained in this document and, to the extent permitted by law, will not be liable for any inaccuracies, omissions or errors in this information nor for any actions taken in reliance on this information. Tilling Timber Pty Ltd reserves the right to change the information contained in this document without prior notice. It is important that you call the technical support customer Helpline on 1300 668 690 to confirm that you have the most up to date information available.

# SmartLam® GLT15S

## Introduction

SmartLam GLT15S beams are manufactured for Tilling Timber by 3<sup>rd</sup> party audited quality GLT manufacturers to AS/NZS 1328. SmartLam GLT15S GLT beams are engineered timber products with high strength, dimensional stability, great load carrying capacity and superior fire resistance.

All timber used for laminating is carefully selected from production and graded according to specification. After trimming to the desired size, all stock is kiln dried to 12% average moisture content, to ensure efficient bonding in the gluing operations. The laminations are finger jointed by machine, with glue being cured by cold press system and controlled temperature.

## Benefits of SmartLam GLT15S

**Cost Effectiveness** - SmartLam GLT15S beams high strength to weight ratio allows you to design for maximum loads over large spans with the smallest possible end sections.

**Product Quality** - All SmartLam GLT15S beams are manufactured in accordance with AS/NZS 1328 Glue Laminated Structural Timber and the Glued Laminated Timber Association (GLTAA) Industry standard GLTAA-4-91.

**Fire safety** - Extensive fire test data shows that large end section timber performs well in fire situations due to the formation of a protective layer of char which usually occurs at a temperature around 250° C. This charred area inhibits the effects of the fire on the inner portion of the timber component, hence it maintains structural load support for measurable periods of time as the fire progresses.

Conversely, steel loses its strength rapidly as the temperature is raised. At about 550°C, it has lost about 50% of its original bending strength, and by 750°C it has lost 90%. Timber does not lose strength in the same way, with the loss of section size through charring the major reason for any strength reduction.

**Fast easy erection** - Timber is a user friendly building material, requiring no special tools other than those a normal builder would use, and with SmartLam GLT15S beams, installation is fast, easy and efficient.

**Environmental responsibility** - SmartLam GLT15S beams are made from timber from sustainable managed forests - PEFC/21-32-02-018

**Low maintenance** - In most applications, SmartLam GLT15S beams will require little or no maintenance other than that which you would ordinarily carry out to any structural material.

**Natural beauty** - The natural beauty of timber is desired and highly appropriate in many architectural applications. Appearance Grade B SmartLam GLT15S beams allow you to build timber's natural warmth and beauty into your designs.

## Ordering SmartLam GLT15S

Stock SmartLam GLT15S GLT is straight (not pre-cambered) and Appearance Grade B.

AS/NZS 1328.2 defines 3 appearance grades:

1. Appearance Grade A - Sanded with any voids filled - intended for applications where appearance is important and clear or painted finishes are used
2. Appearance Grade B - intended for applications where appearance is important but where a planed finish is acceptable
3. Appearance Grade C - intended for applications where appearance is unimportant

## SmartLam GLT15S B grade

"C" indicates pre-camber  
"S" indicates no-pre-camber (straight)

Appearance grade

## Protection and handling

Care should be taken during delivery to avoid marking and to avoid damage. Unloading of trucks should be done by hand or with a crane, do not drop or dump members. During unloading with lifting equipment, use fabric or plastic belts or other slings which will not mark the wood. If chains or cables are used, provide protective blocking or padding. Guard against soiling, dirt, footprints, abrasions, or injury to sharp edges or corners.

## Installation

### Preparatory work

Carefully unload and handle the laminated members at job site to prevent surface marking and damage. If laminated timber is to be stored before erection, place it on blocks well off the ground with individual members separated by strips so that air may circulate around all four sides. The top and the sides of storage pile shall be covered with moisture resistant covering. Wrapping shall be left intact, but individual wrappings shall be slit or punctured on the lower side to permit the drainage of water that may have accumulated. Before erection, the assembly should be checked for any damage from water or handling, prescribed camber, and accuracy of anchorage connections.

Laminated beams can be nailed into place in the same way as solid timber beams. Alternatively, a range of plates are available for end fixing. For larger beams, special purpose, engineer designed end fixing should be used.

### Deflection

All structural members deflect downwards when dead loads are applied, and therefore it is important to allow for this deflection structurally and/or aesthetically in the selection of the beam sizes. The "Deflection Limits" table on page 10 details deflection limits for various applications.

### Verticality

SmartLam GLT15S members must not be installed out of plumb more than height/500.

### Holes for services

Horizontal Holes - Like notches, holes in a GLT beam remove wood fibre, reduce the net area of the beam at the hole location, and introduce stress concentrations. For this reason, horizontal holes in GLT beams are limited in size and location to maintain the structural integrity of the beam. The diagram on the next page shows the zones of a uniformly loaded, simply supported beam where field drilling of holes may be considered.

Field drilled horizontal holes should be for access only and should not be used as attachment points for brackets or other load bearing hardware unless specifically designed as such by the Engineer/Designer.

Regardless of the hole location, the net section of the beam remaining should be checked for flexure and horizontal shear.

Vertical holes - As a rule of thumb, vertical holes drilled through the depth of a GLT beam cause a reduction in capacity at that location directly proportional to the ratio of 1½ times the diameter of the hole. For example, a 25 mm hole drilled in a 150 mm wide beam would reduce the capacity of the beam at that section by ¼. For this reason, where it is necessary to drill vertical holes through

## Installation (cont'd)

a GLT member, the holes should be positioned in areas of the member that are stressed to less than 50% of the design in bending.

Holes for support of heavy equipment - Heavy equipment or piping suspended from GLT should be attached so that the load is applied

to the top of the member to avoid tension perpendicular to the grain stresses. Any horizontal holes required for support of significant weight, such as suspended heating and cooling units or main water lines, must be located above the neutral axis of the member and in a zone stressed to less than 50% of the design flexural stresses.

### Zones where horizontal holes are permitted in a uniformly loaded simply supported beam

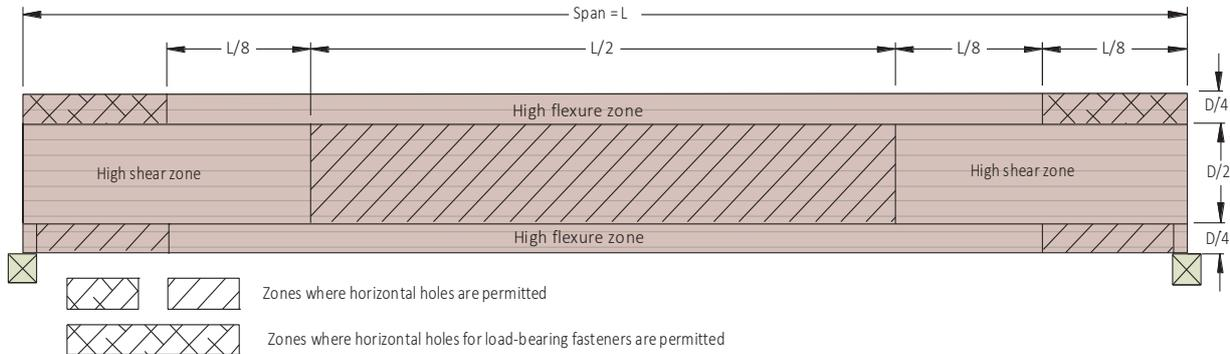

## Notches

Notching of bending members should be avoided whenever possible, especially on the tension side of a member.

Tension-side notching of GLT beams is not permitted except at end bearings and then only under specific conditions. The notching of a bending member on the tension side results in a decrease in strength caused by stress concentrations which develop around the notch, as well as a reduction of the area resisting the bending and shear forces. Such notches induce perpendicular-to-grain tension stresses which, in conjunction with horizontal shear forces, can cause splitting along the grain, typically starting at the inside corner of the notch.

Where GLT members are notched at the ends for bearing over a support, the notch depth shall not exceed 1/10 of the beam depth. Figure (e) is provided to assist in evaluating the associated reductions to beam strength due to notching on the tension side.

For notches on the compression side, a less severe condition exists and equations for the analysis of the effects of these notches are also given in Figure (a) to (d). The equations given are empirical in nature and were developed for the conditions shown.

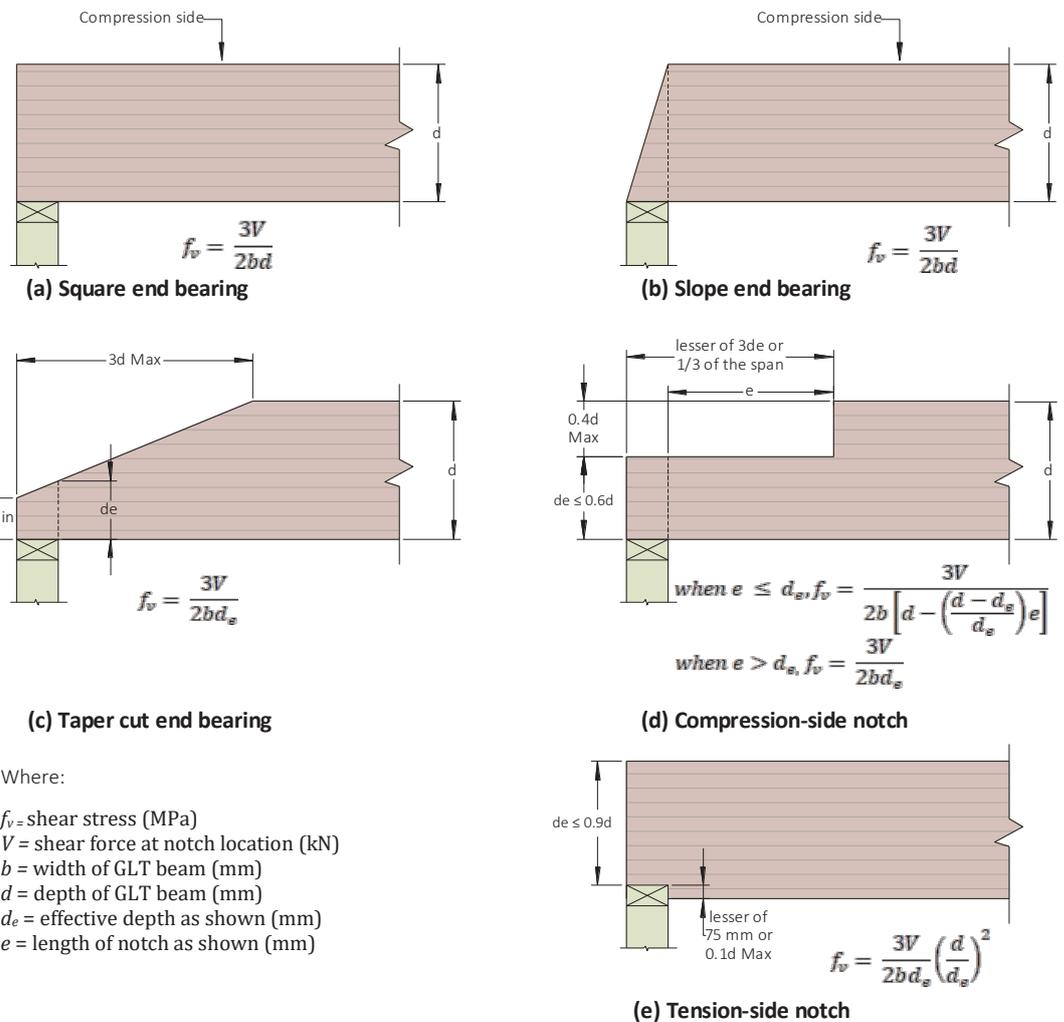

As this guideline is limited to single span, simply supported beams, the notches shown in Figure (b) and (c) occur in areas of high shear and effectively zero moment. For this reason, the design equations given are shear equations. In situations where compression side notches extend into areas of significant moment, the bending capacity of the beam should also be checked using the remaining section of the beam and the appropriate allowable

## Installation (cont'd)

stresses for those laminations remaining at the notch location.

When it becomes necessary to cut a small notch in the top of a GLT beam (in the compression zone) to provide passage for small diameter pipe or conduit, this cut should be made in areas of the beam stressed to less than 50% of the design bending stress. The net section in these areas should be checked for shear and bending stresses to ensure adequate performance.

All field notches should be accurately cut. Avoid over-cutting at the root of the notch. Drilling a pilot hole in the member at the interior or corner location of a notch as a stop point for the saw blade provides both a rounded corner and minimizes over-cutting at the corner.

Stress concentrations due to notches can be reduced by using a gradually tapered notch configuration in lieu of a square-cornered notch. Rounding the square corner of a notch with a radius of approximately 12 mm is also recommended to reduce stress concentrations in these areas.

For square-cornered notches occurring at the ends of beams on the tension side, the designer may consider the use of reinforcement, such as full-threaded lag screws, to resist the tendency to split at the notch (See diagram below). A number of design methodologies exist for sizing such screws.

The design methodology selected and subsequent fabrication details are the responsibility of the project designer/engineer. If lag screws are used, lead holes shall be predrilled in accordance with accepted practice. This procedure can also be used as a field remedy to minimize further propagation of an existing crack.

Further information about the use of screw reinforcement can be obtained by contacting the technical support Helpline on 1300 668 690 or e-mail at techsupport@tilling.com.

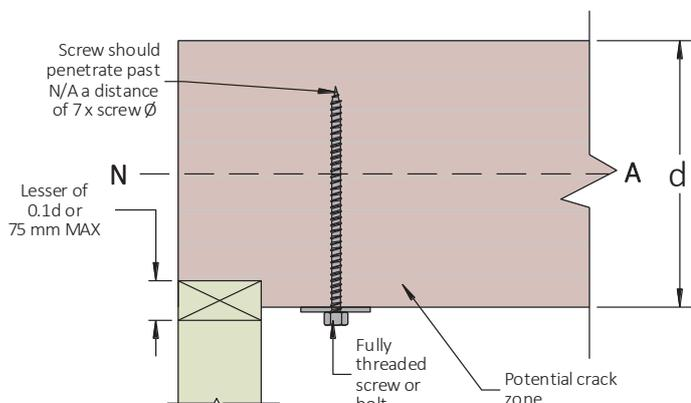

### Birdsmouthing

Figure 3 - Birds mouting details for SmartLam GLT15S

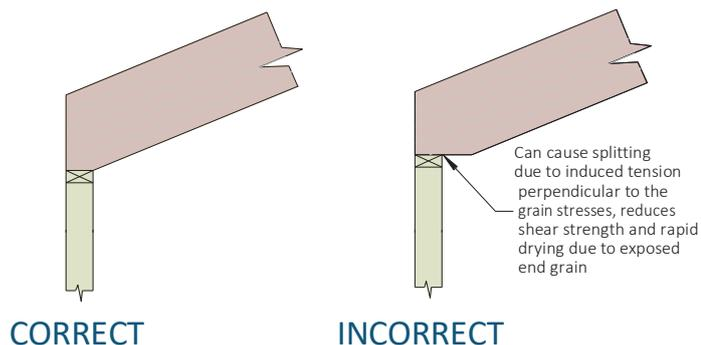

### Eaves overhang

Figure 4 - Eaves overhang details for SmartLam GLT15S

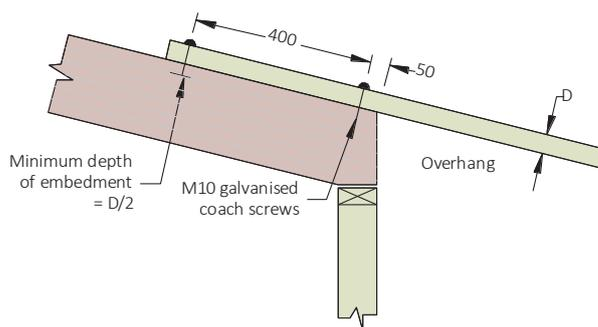

Note: Refer to AS 1684 Residential timber-framed construction code for overhang member size.

### Allowable Eaves overhangs

#### 1. Non Cyclonic Areas

Beams for flat or similar roofs - Not Birds mouthed: Eaves overhang shall not exceed 40% of the actual beam span.

Beams with conventional pitched roofs - Birds mouthed to one third their depth:

- I. Sheet roof - 20% of actual beam span
- II. Tiled roof - 30% of actual beam span

#### 2. Cyclonic Areas

Recommendations as per above, but reduced as follows:

Non Birds mouthed:

- 25% of actual beam span

Birdsmouthed:

- Sheet roof - 10% of actual beam span
- Tiled roof - 20% of actual beam span

### Steel and Timber fixing to SmartLam GLT15S

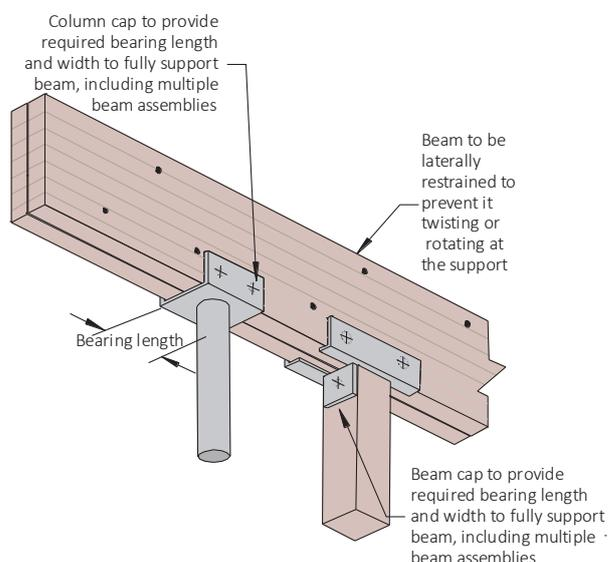

# Installation (cont'd)

## Multiple SmartLam GLT15S section beams

Vertical laminations may be achieved by adopting the principle described in clause 2.3 of AS 1684, however, due to the thickness of SmartLam GLT15S, nails are NOT suitable for combining SmartLam GLT15S beams.

Experience with GLT beams indicates that multiple member laminations individual components may cup as a result of the ingress of moisture between laminates during construction. The suggested method of vertical lamination shown below provides a greater level of fixity between individual components, and combined with

the use of a temporary waterproof membrane and an elastomeric adhesive prevents moisture penetration between the laminates.

Maximum floor load width tables for multiple member laminations of SmartLam GLT15S:

1. Type 17 screw lamination

2. Bolt lamination

are shown below.

### 1. Type 17 screws

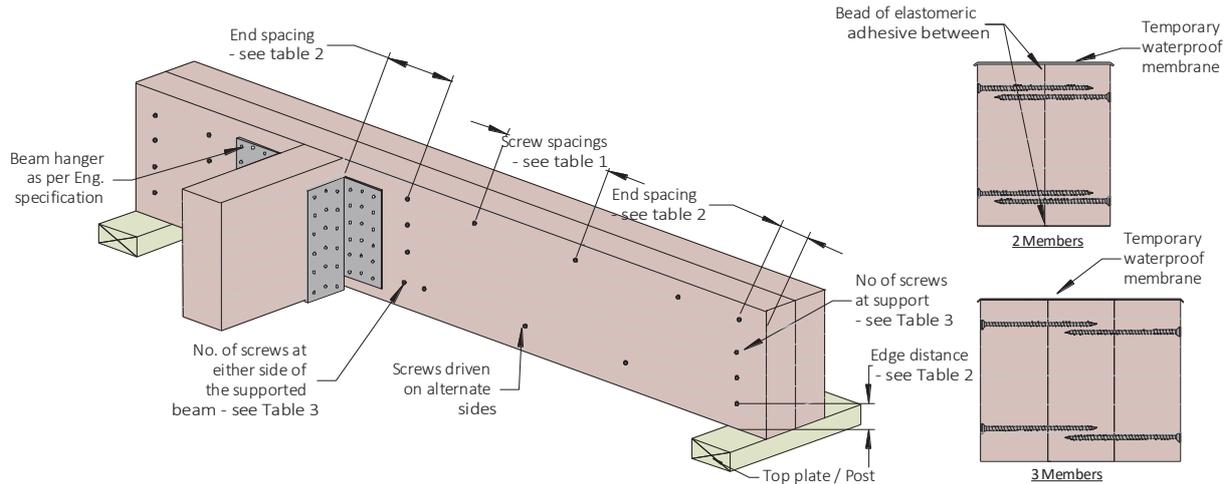

Table 1

Side (non-symmetrically) and top loaded beam				
Section width	Type 17 screw size	No of screw rows (both sides)	Screw spacing (mm)	Max. floor joist span supported by outer member (mm)**
2/75 & 3/75	14g x 100	2 or 3*	300	7700
2/60 & 3/60	14g x 125	2 or 3*	300	6000

\* for beam depths  $\geq 300$  mm, use 3 rows of screws  
 \*\* Floor loads G = 1.25 kPa, Q = 2.0 kPa

Table 2

Type 17 screw size	Min. edge distance (mm)	Min. end distance (mm)	Min. distance between screws (across the grain) (mm)
14g	40	70	30

Table 3

Beam depth (mm)	Min. number of screws required	
	At support	At either side of supported beam
90 - 240	3	3
> 240	4	4

### 2. Bolts

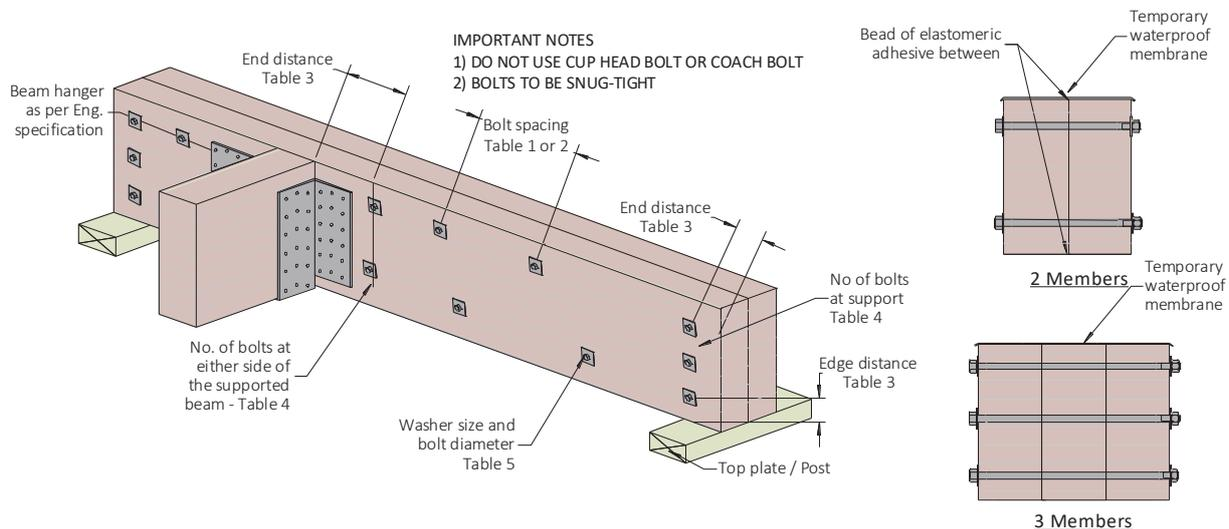

**IMPORTANT NOTES**  
 1) DO NOT USE CUP HEAD BOLT OR COACH BOLT  
 2) BOLTS TO BE SNUG-TIGHT

# Installation (cont'd)

## 2. Bolts (Cont'd)

Table 1

Top (symmetrically) loaded beam - M12 Hex head bolt	
Beam depth ≤ 300 mm	Beam depth > 300 mm
2 rows of bolts at 600 mm ctrs	3 rows of bolts at 600 mm ctrs

Table 2

Side (Non symmetrically) loaded beam - M12 Hex head bolt		
Maximum floor joist span supported by the beam mm*		
2 rows at 600 mm ctrs	2 rows at 300 mm ctrs	3 rows at 600 mm ctrs
11,00 mm	>12	>12

\* based upon floor loads of G: 1.25 kPa Q: 2.0 kPa

Table 3

Bolt size	Min. edge distance	Min. end distance	Min. distance between bolts (across grain)
M12 Hex head	60 mm	60 mm	60 mm

Table 4

Beam depth (mm)	Min. number of bolts required	
	At support	At either side of supported beam
90 – 150	1	1
160 – 240	2	2
> 240	3	3

Table 5

Bolt diameter (mm)	Washer dimensions		
	Thick-ness (mm)	Min. diameter of round washers (mm)	Min. side length of square washers (mm)
M12	3	55	50

## SmartLam durability and weather exposure

### AS 1684 definitions of exposure zones within a structure

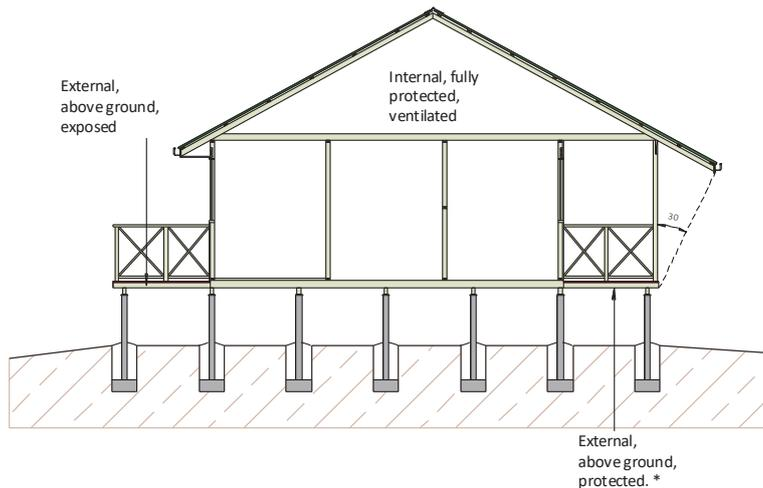

\* External timbers are regarded as protected in AS 1684 if they are covered by a roof projection (or similar) at 30° to the vertical and they are well detailed and maintained (painted and kept well ventilated).

SmartLam GLT15S's are manufactured from kiln dried timber (MC less than 15%), and therefore need to be protected from moisture cycling that can occur from:

- Exposure to direct sun and rain (including during construction)
- Contact or close exposure with moisture laden porous material (e.g. Concrete blocks)
- Exposure to extreme environments such as dry heating systems (e.g. slow combustion wood heaters), air conditioning, large north or west facing windows or moisture laden environments such as pool enclosures.

### SmartLam GLT15S protection methods

#### During Construction (pre - water proof roof)

SmartLam GLT15S's are supplied WITHOUT any short term construction sealer. However if SmartLam GLT15S is expected to be

exposed for an extended period or become wet, it is recommended that the beam be sealed with a construction sealer that is compatible with the final paint or varnish finish, or wrapped in plastic to provide protection (plastic must allow for drainage and air circulation to breath).

Examples:

- If the SmartLam GLT15S is installed inside a building without direct exposure to air-conditioning such as in wall cavity, NO protection to the beam is required.
- If the SmartLam GLT15S is installed inside a building with direct exposure to air conditioning or dry heat then a sealer is required.
- If the SmartLam GLT15S is under the eaves and protected from direct rain and sun, it is recommended that the construction sealer be lightly sanded and a finish coat of compatible premium quality paint be applied. (In accordance with paint manufacturer's specifications).

## Durability and exposure to moisture (Cont'd)

### Moisture effects on SmartLam GLT15S

SmartLam GLT15S, like all wood products, is hygroscopic, which means it has an affinity for water, and being a GLT, should be considered as a composite of many pieces of wood, each with different potential swelling. Moisture exposure will ultimately lead to dimensional change.

While the products will withstand normal exposure, excessive exposure during distribution, storage or construction may lead to dimensional changes that affect serviceability. These changes include cupping, bowing or expansion to dimensions beyond the specified tolerance of the product in the “as-manufactured” condition.

Individual members of a vertically laminated multi member may exhibit some cupping if water becomes trapped between the laminates. This cupping produces more of a visual and possible fixity problem rather than being structurally significant. If not properly dried out, this moisture between laminated members may lead to decay. To prevent this effect, use construction details as shown on page 5

As an organic material, mould and mildew may grow on untreated wood products if moisture is present. Prolonged periods of high moisture may also support the growth of wood decay fungi.

In critical applications where dimensional change due to moisture exposure is to be absolutely minimised (e.g. truss applications in wet humid conditions) it is recommended that remedial water repellent be used to recoat any cut ends or notches etc.

The table below shows the moisture content of SmartLam GLT15S as a function of humidity.

Moisture content of wood products % <sup>(1)</sup>	
Relative Humidity %	GLT MC
10	1.2
20	2.8
30	4.6
40	5.8
50	7.0
60	8.4
70	11.1
80	15.3
90	19.4

1. Approx. moisture content at 21°C

### Dimensional change

SmartLam GLT15S will shrink and swell in proportion to changes in moisture content between 0 and 28 % fibre saturation point.

The most significant moisture movement will occur across the grain (tangential and radial directions within a log). Longitudinal (movement in the grain direction) may be a factor depending upon the type of structure. Detailing of SmartLam GLT15S to be used where moisture contents will cycle should allow for dimensional instability.

The AVERAGE amount of dimensional change in a piece of GLT changes in moisture content can be APPROXIMATED by the following formula:

$$\Delta D = D_i S (MC_i - MC_f) / FSP$$

Where:

$\Delta D$  = change in dimension

$D_i$  = Initial dimension

$S$  = Shrinkage coefficient = approximately 6%

$MC_i$  = Initial moisture content

$MC_f$  = final moisture content

FSP = fibre saturation point approximately 28%

NOTE: these dimensional effects are quite variable.

### Change in characteristic strengths

Changes in moisture content in wood results in changes in mechanical properties, with higher properties at lower moisture contents. Estimates of the effect of moisture differentials on the properties of clear wood may be obtained by the following equation:

$$P = P_{12} \left( \frac{P_g}{P_g} \right)^{\left( \frac{12-M}{M_p-12} \right)}$$

Where:

$P$  = Characteristic property at moisture content

$P_{12}$  = same Characteristic property at 12% moisture content

$P_g$  = same Characteristic property for Green wood

$M_p$  = Intersection moisture content ~ 25% for Eucalypts

The APPROXIMATE effect upon key Characteristic Properties of SmartLam GLT15S by changes in MC are outlined in the table below:

Characteristic Property		% Reduction in Characteristic strength at % MC					
		14	16	18	20	22	24
MOE (Stiffness)	E	3.3	6.5	9.7	12.7	15.6	18.4
MOR (Bending)	$F'_b$	8.4	16.1	23.1	29.6	35.5	40.9
Compression perpendicular to grain	$f'_p$	9.9	18.9	27.0	34.2	40.8	46.7
Compression parallel to grain	$f'_c$	11.0	20.7	29.4	37.2	44.1	50.2
Shear	$f'_s$	6.6	12.8	18.6	24.0	29.0	33.7

The design Characteristic properties of SmartLam GLT15S can therefore be considerably reduced by severe increase in MC of the GLT.

If the SmartLam GLT15S is being built into structures (such as Pre-fabricated trusses) that are:

1. Likely to experience large increase in MC due to weather exposure or stored on the ground
2. Likely to be loaded to at/or close to design loads while in the high MC state

then the reduced Characteristic Strengths as detailed above NEED to be used in the design or members may require temporary propping.

Once covered, the SmartLam GLT15S will ultimately dry and equilibrate to the ambient humidity conditions, but some expansion or swelling will remain after re-drying.

### Design for durability

- i. The use of building overhangs and other structures which protect the beams from excessive moisture movement and sun exposure.
- ii. All beams should be provided with adequate ventilation so that moisture content within beams will not exceed 15% and moisture gradients across the beam will not occur.
- iii. The use of arrised or round edges on beams to reduce the likelihood of coating failures on sharp edges.

## Durability and exposure to moisture (Cont'd)

- iv. The use of drip edges or other devices which provide a path for free moisture flow away from the timber beam.
- v. Joint detailing should, wherever possible, comply with the following:
  1. Keep horizontal contact areas to a minimum, in favour of self draining vertical surfaces.
  2. Ventilate joint surfaces by using spacers, wherever possible
  3. Always use compatible fasteners which have adequate corrosion protection and do not cause splitting during installation e.g. hot dipped galvanic coatings or stainless steel
  4. Ensure any moisture entering a joint is not trapped but

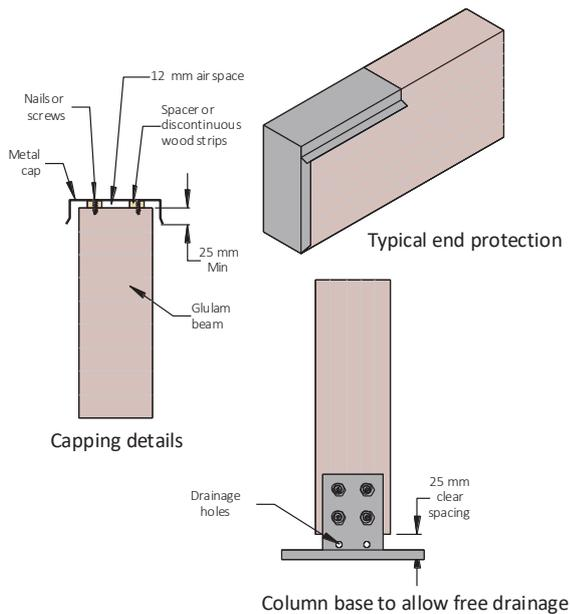

can adequately drain away from the joint.

Allow for thermal expansion/contraction in the joint design.

### Post-Production treatment

SmartLam GLT15S can be supplied Tru-Core® treated to either H2 or H3 hazard class levels, as per AS/NZS 1604.1 (Tru-Core® is a registered trade mark of Kop-Coat Australia PTY Limited ). **To maintain effective treatment it is a requirement that any cuts, notches or penetrations made in post production treated SmartLam GLT15S be painted with a suitable “brush/spray on” preservative.**

The hazard class number selected is based upon the specific exposure condition for the proposed end use of the SmartLam GLT15S, as shown in the table below.

A more comprehensive Hazard Class Table is available in AS/NZS 1604.1 but it is **NOT** recommended that SmartLam GLT15S be used in end uses with exposures requiring treatment in excess of H3.

(1) Experience is showing that post production treated GLT in the **external above ground, exposed** (H3 Hazard Class) may experience some leaching of the active ingredients of the treatment. To minimise the possibility of timber degradation in these situations, it is recommended that H3 treated SmartLam NOT be used where the surface is horizontally exposed AND unprotected from water entrapment OR where post-treatment protection cannot be maintained.

Post treatment protection may include:

- (i) Protectadeck™ high density water proof joist/ bearer cover or malthoid capping
- and**
- (ii) An impervious membrane such as regularly maintained painting or staining
  - (iii) Construction detailing to prevent water entrapment.

H3 treated SmartLam GLT15S is NOT recommended for fascia's, pergolas or other similar **external above ground, exposed** applications due to mechanical degradation of the wood fibre causing checking and cracking which is both aesthetically unacceptable and allows ingress of water to inner sections.

### Fasteners for H3 SmartLam GLT15S

For any H3 SmartLam GLT15S to be used in exposed exterior applications, it is recommended that either hot dipped galvanised or stainless steel fasteners are used.

Specifically, If the Tru-Core® Copper Quat H3 treatment process is used, high grades (304, 305 and 316) of stainless steel materials perform the best.

### Painting of treated SmartLam GLT15S

#### 1. General

To provide the longest service life of the SmartLam GLT15S it is recommended the GLT is painted with an exterior paint with a Light Reflectance Value (LRV) greater than 30%. Heat reduction exterior paints should be used where the desired colour is dark or has a LRV of less than 30% The heat reflective paint's colours should be limited to a Total Solar Reflectance (TSR) value greater than 29%.

Any paint or stain must be recommended by the manufacturer as being suitable for the proposed application and must be applied in a manner in strict compliance to the manufacturer's recommendations

1. The wood must be dry and clean prior to applying any finish coating. If initial cleaning of the treated wood is needed, it is recommended that the project be cleaned with a deck cleaning product and allowed to fully dry.
2. At this time, a clear water repellent may be added to the project. If applied, allow 8 weeks prior to the application of a semi-transparent stain or paint
3. If no water repellent is added, an oil based stain can be

Hazard class selection guide				
Hazard class	Exposure	Specific service conditions	Biological hazard	Typical uses
H1 <sup>†</sup>	Inside, above ground	Completely protected from the weather and well ventilated, and protected from termites	Lyctid borers	Interior beams, staircases, stringers
H2S <sup>†</sup>	Inside, above ground	Protected from wetting Nil leaching	Borers and termites	Interior beams, staircases, trusses, joists
H2	Inside, above ground	Protected from wetting Nil leaching	Borers and termites	Interior beams, staircases, trusses, joists
H3	External, above ground	Subject to periodic moderate wetting and leaching	Moderate decay, borers and termites	Exterior beams <sup>(1)</sup>

## Durability and exposure to moisture (Cont'd)

applied to the clean, dry wood in 30-60 days from treatment date

4. A water based stain can be applied to the clean, dry wood in 45-70 days from treatment date.
5. Depending on the treatment method used, if the wood is left uncoated and without UV protection:
  - i. The typical brown colour of the Copper Quat treated wood will naturally weather to a grey colour over long-term exposure to the sun
  - ii. The Azole treated wood has no colouration so it will naturally weather to a grey colour over long-term exposure to the sun.

Users must always conduct their own tests on coatings in inconspicuous areas of the project to determine acceptability of colour, adhesion and appearance.

### Covered alfresco beams

Alfresco beams constructed to comply with the diagram below are technically classified in AS 1684 as **External, above-ground, protected**. (see previous page)

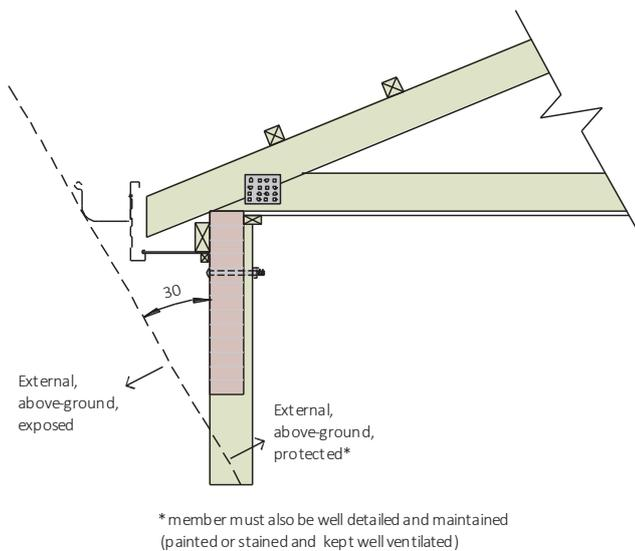

SmartLam GL's used in protected exterior applications must be:

- I. Correctly detailed by fully enclosing member with a mechanical barrier such a cement sheet if it is likely to get wet or experiences direct sun
- II. Mechanical barrier correctly painted with a premium quality protective finish (e.g. light coloured pigmented external paint system) to prevent moisture infiltration.

It is important that an inspection and maintenance programme, based on exposure level and the paint manufacturer's recommendations be prepared.

### H3 Deck bearers and joists

H3 Treated Deck joists and bearers are a common application for treated SmartLam GLT15S. The diagram demonstrates the minimum construction detailing for H3 treated joists and bearers. Failure to follow these guidelines may render treatment warranties void.

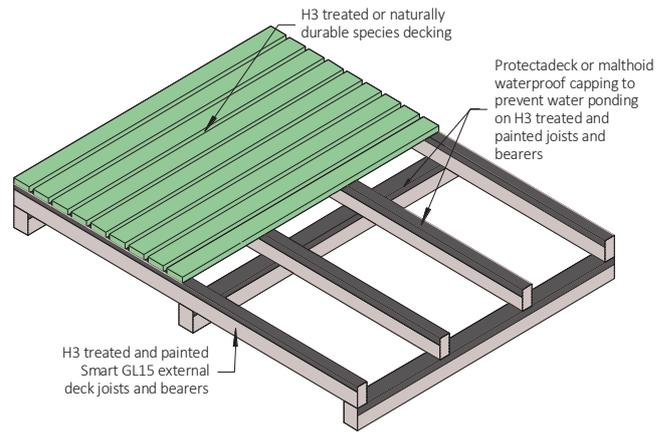

It is recommended that deck nails be slightly skewed as per the detail below.

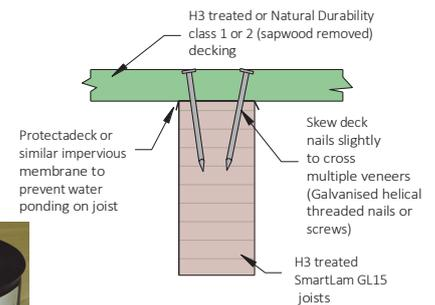

Recommended proprietary top protection for joists and bearers

### Fire resistance

The Fire Resistance Level (FRL) is the performance criteria for fire resistance, i.e. the grading periods (in minutes) for the following criteria as specified in the BCA:

- a. Structural adequacy: (the duration for which the elements can carry its designated load)
- b. Integrity: (the duration for which the element can maintain its integrity to prevent the spread of fire to/from the compartment)

and

- c. Insulation: (the duration for which the element is insulating the adjacent space from excessive temperature rise)

and is expressed in that order e.g. 30/30/30. The method for determining the structural component of the Fire Resistance Period for timber (including LVL and GLT) is described in AS /NZS 1720.4 - 2019 Timber Structures Part 4: Fire resistance of timber elements.

$$c = 0.4 + \left( \frac{280}{\delta} \right)^2$$

where:

c = notional charring rate, in mm per minute

d = timber density of SmartLam GLT15S - ~650 kg/m<sup>3</sup>

The effective depth of charring ( $d_e$ ) after a period of time (t) shall be calculated in accordance with Clause 2.6.1 for surfaces exposed to fire and in accordance with Clause 2.6.2 for surfaces behind fire-resistant protective insulation.

Further information about using SmartFrame product in fire rated applications can be obtained by contacting the Techsupport Helpline on 1300 668 690 or email techsupport@tilling.com.au.

# Designing with SmartLam GLT15S

The design information contained within this Design Guide is for the properties of SmartLam GLT15S only. Other manufacturers' GLT may have different properties and therefore cannot be designed using this information.

## 1. Product Specification

<b>Lamella:</b>	Thickness:	25-45 mm
	Species:	Tas Oak (E. delegatensis, E. obliqua & E. regnans )
	Strength Group	SD3
	Joints:	Finger joint
<b>Dimensional tolerances:</b>	Length:	± 10 mm
	Depth:	≤ 100 mm ± 1 mm ≥ 100 ≤ 302 mm ± 3 mm ≥ 301 ≤ 600 mm ± 4 mm ≥ 601 ± 6 mm
	Thickness:	- 0, +4 mm at 12% moisture content
<b>Adhesive:</b>	Complies with AS/NZS 4364:2010	
<b>Treatment options:</b>	Un-treated and H3	

## 2. Limit State Design Characteristic Properties

Timber Strength Properties: <sup>(1)</sup>		
Bending	f <sub>b</sub>	40 MPa
Tension Parallel to grain	f <sub>t</sub>	24 MPa
Tension Perpendicular to grain	f <sub>tp</sub>	0.6 MPa
Compression Parallel to grain	f <sub>c</sub>	26 MPa
Compression Perpendicular to grain - Edge	f <sub>p</sub>	17 MPa
Shear	f <sub>s</sub>	4.1 MPa
Average Elastic Modulus	E	15,200 MPa
Average Modulus of Rigidity	G	1010 MPa
Average Density		650 kg/m <sup>3</sup>
Moisture Content		12-15%

(1) Dry conditions

## 3. Strength reduction factor

The strength reduction factor for calculating the design capacities of structural members shall be taken from the table below, referenced from AS 1720.1 –2010

Application of SmartLam GLT15S as a structural member		
Category 1	Category 2	Category 3
Structural members for houses for which failure would be unlikely to affect an area greater than 25 m <sup>2</sup> ; OR secondary members in structures other than houses	Primary structural members in structures other than houses; OR elements in houses for which failure would be likely to affect an area* greater than 25 m <sup>2</sup>	Primary structural members in structures intended to fulfil essential services or post disaster function
<b>Strength reduction factor <math>\phi</math> *</b>		
0.95	0.85	0.75

\* AS 1720.1:2010 Table 2.1

## 4. Duration of load

The duration of load factor k<sub>1</sub> for strength is defined within clause

Duration	Service class / exposure classification		
	1, 2	3	Severe/ Adverse
Short term ≤ 1 Day	1.0	1.0	1.0
Long term > 12 months	1.5	2.0	3.0*

Notes:

- \* Any beams to be used in service class 3 are outside the scope of these span tables, therefore specialist design advice should be sought from an engineer.
- In general, the size of this beam can conservatively be obtained by the following method:
  - Obtain the beam size for service class 1 & 2
  - Obtain the EI<sub>xx</sub> from the "Section Properties" table for this beam
  - Obtain from the "Section Properties" table a beam size with an EI<sub>xx</sub> => 2/1.5 x EI<sub>xx</sub> of the original beam
  - Follow the recommendations for SmartLam durability and weather exposure on page 6
- Service Classes 1,2 & 3 are defined in AS 1328

## 5. Partial seasoning factor

SmartLam GLT15S is a seasoned timber product, generally k<sub>4</sub> equals 1. Where the GLT is subjected to conditions in which the average moisture content for a 12 month period is expected to exceed 15%, the characteristic capacity shall be decreased. The value of k<sub>4</sub> shall be the greater of:

- $k_4 = 1 - 0.3 \frac{EMC - 15}{10}$ ;
- $k_4 = 0.7$

Where EMC is the highest value of the annual moisture content (percent) that the timber will attain in service.

## 6. Length and position of bearing

The k<sub>7</sub> bearing factor is defined is clause 2.4.4 of AS 1720.1

## 7. Load sharing

Because of the reduced variability of strength values of GLT compared to solid timber, the load sharing factor k<sub>9</sub> = 1.0 as defined in clause 7.4.3 of AS 1720.1

## 8. Stability

The stability factor k<sub>12</sub> is defined within section 7 of AS 1720.1 beams. The methods for calculating k<sub>12</sub> for solid wood in section 3 of AS 1720.1 shall generally apply except that the material constant (ρ<sub>b</sub> or ρ<sub>c</sub>) for beams and column shall be as given in Tables 7.2(A) and 7.2(B)

## 9. Temperature

For covered timber structures under ambient conditions, no modification for strength need be made for the effect of temperature (i.e., k<sub>6</sub> equals 1.0) except that where seasoned timber is used in structures erected in coastal regions of Queensland north of latitude 25°S, and all other regions of Australia north of latitude 16°S, the strength shall be modified by a factor k<sub>6</sub> of 0.9.

## SmartLam GLT15S Beam Properties

Nominal Size DxB mm	Beam Mass kg/m	Nominal section area 10 <sup>3</sup> mm <sup>2</sup>	Major axis			Minor axis	
			Zxx 10 <sup>3</sup> mm <sup>2</sup>	Ixx 10 <sup>6</sup> mm <sup>4</sup>	EIxx 10 <sup>9</sup> Nmm <sup>2</sup>	Zyy 10 <sup>3</sup> mm <sup>2</sup>	Iyy 10 <sup>6</sup> mm <sup>4</sup>
120 x 45	3.5	5.4	108	6	98	40.5	0.9
140 x 45	4.1	6.3	147	10	156	47.3	1.1
160 x 45	4.7	7.2	192	15	233	54.0	1.2
180 x 45	5.3	8.1	243	22	332	60.8	1.4
200 x 45	5.9	9.0	300	30	456	67.5	1.5
220 x 45	6.4	9.9	363	40	607	74.3	1.7
240 x 45	7.0	10.8	432	52	788	81.0	1.8
260 x 45	7.6	11.7	507	66	1002	87.8	2.0
280 x 45	8.2	12.6	588	82	1251	94.5	2.1
300 x 45	8.8	13.5	675	101	1539	101.3	2.3
320 x 45	9.4	14.4	768	123	1868	108.0	2.4
340 x 45	9.9	15.3	867	147	2240	114.8	2.6
360 x 45	10.5	16.2	972	175	2659	121.5	2.7
380 x 45	11.1	17.1	1083	206	3128	128.3	2.9
400 x 45	11.7	18.0	1200	240	3648	135.0	3.0
420 x 45	12.3	18.9	1323	278	4223	141.8	3.2

120 x 70	5.5	7.8	156	9	142	84.5	2.7
140 x 70	6.4	9.1	212	15	226	98.6	3.2
180 x 70	8.2	11.7	351	32	480	126.8	4.1
200 x 70	9.1	13.0	433	43	659	140.8	4.6
220 x 70	10.0	14.3	524	58	877	154.9	5.0
240 x 70	10.9	15.6	624	75	1138	169.0	5.5
260 x 70	11.8	16.9	732	95	1447	183.1	6.0
280 x 70	12.7	18.2	849	119	1807	197.2	6.4
300 x 70	13.7	19.5	975	146	2223	211.3	6.9
320 x 70	14.6	20.8	1109	177	2698	225.3	7.3
340 x 70	15.5	22.1	1252	213	3236	239.4	7.8
360 x 70	16.4	23.4	1404	253	3841	253.5	8.2
380 x 70	17.3	24.7	1564	297	4518	267.6	8.7
400 x 70	18.2	26.0	1733	347	5269	281.7	9.2
420 x 70	19.1	27.3	1911	401	6100	295.8	9.6
440 x 70	20.0	28.6	2097	461	7013	309.8	10.1
460 x 70	20.9	29.9	2292	527	8014	323.9	10.5
480 x 70	21.8	31.2	2496	599	9105	338.0	11.0
500 x 70	22.8	32.5	2708	677	10292	352.1	11.4
520 x 70	23.7	33.8	2929	762	11577	366.2	11.9
540 x 70	24.6	35.1	3159	853	12965	380.3	12.4
560 x 70	25.5	36.4	3397	951	14459	394.3	12.8
580 x 70	26.4	37.7	3644	1057	16064	408.4	13.3
600 x 70	27.3	39.0	3900	1170	17784	422.5	13.7
620 x 70	28.2	40.3	4164	1291	19622	436.6	14.2

120 x 90	7.0	10.2	204	12	186	144.5	6.1
140 x 90	8.2	11.9	278	19	295	168.6	7.2
180 x 90	10.5	15.3	459	41	628	216.8	9.2
200 x 90	11.7	17.0	567	57	861	240.8	10.2
220 x 90	12.9	18.7	686	75	1146	264.9	11.3
240 x 90	14.0	20.4	816	98	1488	289.0	12.3
260 x 90	15.2	22.1	958	124	1892	313.1	13.3
280 x 90	16.4	23.8	1111	155	2363	337.2	14.3
300 x 90	17.6	25.5	1275	191	2907	361.3	15.4
320 x 90	18.7	27.2	1451	232	3528	385.3	16.4
340 x 90	19.9	28.9	1638	278	4232	409.4	17.4
360 x 90	21.1	30.6	1836	330	5023	433.5	18.4
380 x 90	22.2	32.3	2046	389	5908	457.6	19.4
400 x 90	23.4	34.0	2267	453	6891	481.7	20.5
420 x 90	24.6	35.7	2499	525	7977	505.8	21.5

## SmartLam GLT15S Beam Properties (Cont'd)

Nominal Size DxB mm	Beam Mass kg/m	Nominal section area 10 <sup>3</sup> mm <sup>2</sup>	Major axis			Minor axis	
			Zxx 10 <sup>3</sup> mm <sup>2</sup>	Ixx 10 <sup>6</sup> mm <sup>4</sup>	Elxx 10 <sup>9</sup> Nmm <sup>2</sup>	Zyy 10 <sup>3</sup> mm <sup>2</sup>	Iyy 10 <sup>6</sup> mm <sup>4</sup>
440 x 90	25.7	37.4	2743	603	9171	529.8	22.5
460 x 90	26.9	39.1	2998	689	10480	553.9	23.5
480 x 90	28.1	40.8	3264	783	11907	578.0	24.6
500 x 90	29.3	42.5	3542	885	13458	602.1	25.6
520 x 90	30.4	44.2	3831	996	15139	626.2	26.6
540 x 90	31.6	45.9	4131	1115	16954	650.3	27.6
560 x 90	32.8	47.6	4443	1244	18908	674.3	28.7
580 x 90	33.9	49.3	4766	1382	21007	698.4	29.7
600 x 90	35.1	51.0	5100	1530	23256	722.5	30.7
620 x 90	36.3	52.7	5446	1688	25660	746.6	31.7

200 x 120	15.6	24.0	800	80	1216	480.0	28.8
220 x 120	17.2	26.4	968	106	1618	528.0	31.7
240 x 120	18.7	28.8	1152	138	2101	576.0	34.6
260 x 120	20.3	31.2	1352	176	2672	624.0	37.4
280 x 120	21.8	33.6	1568	220	3337	672.0	40.3
300 x 120	23.4	36.0	1800	270	4104	720.0	43.2
320 x 120	25.0	38.4	2048	328	4981	768.0	46.1
340 x 120	26.5	40.8	2312	393	5974	816.0	49.0
360 x 120	28.1	43.2	2592	467	7092	864.0	51.8
380 x 120	29.6	45.6	2888	549	8341	912.0	54.7
400 x 120	31.2	48.0	3200	640	9728	960.0	57.6
420 x 120	32.8	50.4	3528	741	11261	1008.0	60.5
440 x 120	34.3	52.8	3872	852	12948	1056.0	63.4
460 x 120	35.9	55.2	4232	973	14795	1104.0	66.2
480 x 120	37.4	57.6	4608	1106	16810	1152.0	69.1
500 x 120	39.0	60.0	5000	1250	19000	1200.0	72.0
520 x 120	40.6	62.4	5408	1406	21372	1248.0	74.9
540 x 120	42.1	64.8	5832	1575	23935	1296.0	77.8
560 x 120	43.7	67.2	6272	1756	26694	1344.0	80.6
580 x 120	45.2	69.6	6728	1951	29657	1392.0	83.5
600 x 120	46.8	72.0	7200	2160	32832	1440.0	86.4
620 x 120	48.4	74.4	7688	2383	36226	1488.0	89.3

200 x 140	18.2	28.0	933	93	1419	653.3	45.7
220 x 140	20.0	30.8	1129	124	1888	718.7	50.3
240 x 140	21.8	33.6	1344	161	2451	784.0	54.9
260 x 140	23.7	36.4	1577	205	3117	849.3	59.5
280 x 140	25.5	39.2	1829	256	3893	914.7	64.0
300 x 140	27.3	42.0	2100	315	4788	980.0	68.6
320 x 140	29.1	44.8	2389	382	5811	1045.3	73.2
340 x 140	30.9	47.6	2697	459	6970	1110.7	77.7
360 x 140	32.8	50.4	3024	544	8274	1176.0	82.3
380 x 140	34.6	53.2	3369	640	9731	1241.3	86.9
400 x 140	36.4	56.0	3733	747	11349	1306.7	91.5
420 x 140	38.2	58.8	4116	864	13138	1372.0	96.0
440 x 140	40.0	61.6	4517	994	15106	1437.3	100.6
460 x 140	41.9	64.4	4937	1136	17261	1502.7	105.2
480 x 140	43.7	67.2	5376	1290	19612	1568.0	109.8
500 x 140	45.5	70.0	5833	1458	22167	1633.3	114.3
520 x 140	47.3	72.8	6309	1640	24934	1698.7	118.9
540 x 140	49.1	75.6	6804	1837	27924	1764.0	123.5
560 x 140	51.0	78.4	7317	2049	31143	1829.3	128.1
580 x 140	52.8	81.2	7849	2276	34600	1894.7	132.6
600 x 140	54.6	84.0	8400	2520	38304	1960.0	137.2
620 x 140	56.4	86.8	8969	2780	42263	2025.3	141.8

**Notes:**

- Above table lists all available cross sections possible in this product, but the spans tables only reflect the more common profiles. All sizes are available for design in the SmartFrame software

## SmartLam GLT15S Beam Properties (Cont'd)

- The values for the sizes in *Italics* (70 and 90 120 and 140 mm ) allow for up to a 5 mm thickness (B) undersize. This is to accommodate the raw material purchase from multiple saw mills to reduce the likelihood of supply issues
- The above sizes are for SmartLam GLT15S beams only. See the SmartLam GLT15S Design Guide for sizes of the product.

### SmartLam GLT15S Design /Effective span

Normal structural analysis uses the centreline representation of the member. The term "span" can be defined in a number of ways and these are defined as follows:

**Clear span.** This is the distance between the faces of any support. It is generally the one easiest to measure and read from the drawings

**Nominal span/centre-line span.** This is the distance between the centre of the supports. This span is used to determine bending moments and deflections for continuous spanning members

**Design span/Effective span.** This is the span used for single span members to determine the bending moment, the slenderness of bending members and the deflections. In NZS 3603 this is the dimension referred to as "L", and is defined below.

Design span/Effective span is the distance between -

- The centre of the bearing at each end of a beam where the bearing lengths have NOT been conservatively sized
- The centre of notional bearing that have been sized appropriately, where the size of the bearing IS conservative.

Diagram (a) shows beam where bearings have been designed appropriately. The effective span is taken as the distance between the centre of each bearing area

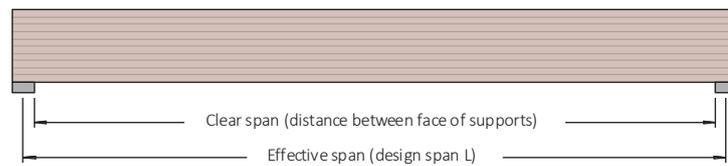
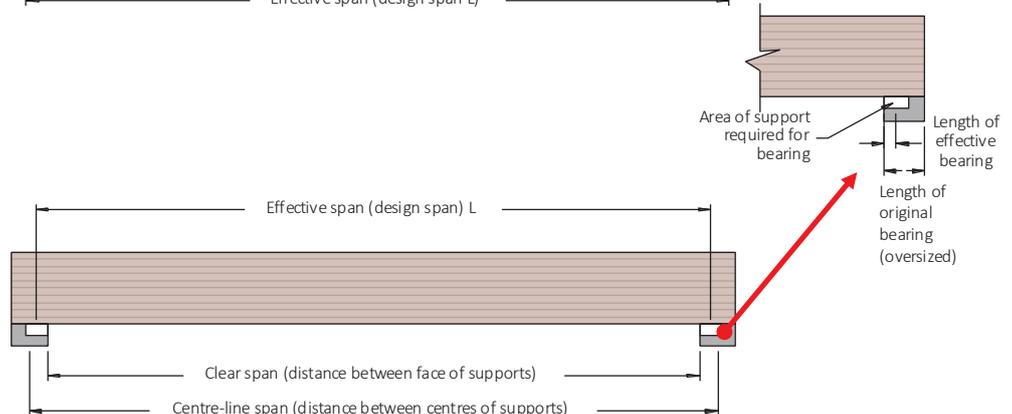

Diagram (b) shows beam where bearings at each end have been oversized. (This is frequently the case for beams that bear onto brickwork or concrete walls where the thickness of the wall is in excess of the area required to give the beam bearing capacity). To find the correct effective span:

- Calculate the minimum bearing required to carry the loads satisfactorily
- Add minimum bearing length to "clear span" distance



span difference	effective span	resultant span description
10% Max	main span	continuous
10 – 30%	1.1 x main span	continuous
Above 30% difference	main span	single

$$\text{span difference} = \frac{(\text{major span} - \text{minor span}) \times 100}{(\text{major span} + \text{minor span})}$$

The span to use in the case of unequal continuous spans is the "resultant span description" as shown in the table above.

(Note: It is recommended for the most accurate designs, that the SmartFrame software be used.)

### Checking in SmartLam GLT15S

One of the advantages of glued laminated timber construction is that while seasoning checks may occur for the same reasons that they do in sawn members, checking in glued laminated timber will generally occur to a much lesser degree because of careful control of the moisture content of timber used for laminating. Checks in wood are separations along the fibres normally occurring across the rings of annual growth resulting from stresses developed during changes in moisture content. Checks in glued laminate timber may appear as openings parallel to the grain on the sides of members.

As wood loses moisture to the surrounding atmosphere, the outer fibres of the member lose moisture at a more rapid rate than do

the inner fibres. As outer fibres try to shrink, they are restrained by the inner portion of the member that has higher moisture content. The more rapid the rate of drying, the greater will be the differential in shrinkage between the outer and inner fibres resulting in higher shrinkage stresses.

These resultant stresses perpendicular to the grain of the wood can cause characteristic wood seasoning checks. The influence of checks on the structural performance of glued laminated timber members is generally minor. Checking can be minimized by careful installation practices that avoid prolonged exposure of the members during construction.

# Checking in SmartLam GLT15S (Cont'd)

## Identification of checking

Checks occur as transverse separations or openings that are nearly parallel to the grain direction in glued laminated timber and generally follow the grain direction around knots and along sloping grain. Differences in the shrinkage rate of individual laminations used in glued laminated timber tend to concentrate shrinkage stresses at or near glue lines, resulting in checks.

Checks are often confused with delamination that occurs when the glue bond is not adequate. The presence of wood fibre separation in these openings is the key distinguishing characteristic of seasoning checks. Openings due to inadequate adhesive bonding may appear as smooth wood surface separations, possibly darkened by the adhesive film, or as glossy surface areas of adhesive with an absence of torn wood fibres.

Checking often occurs along the first glue line adjacent to the outer lamination that may dry more rapidly because a larger surface area of that lamination is exposed to the air. This condition is sometimes aggravated when the outer lamination tends to cup, creating tension perpendicular to grain stresses along or near the first glue line.

## Significance of checking

In general, checks have little effect on the strength of glued laminated members. Glued laminated members are made from laminations that are thin enough to season readily in kiln drying schedules without developing checks. Checks usually appear on the wide faces of the timber and do not materially affect the shear strength of the laminations. In cases where members are designed

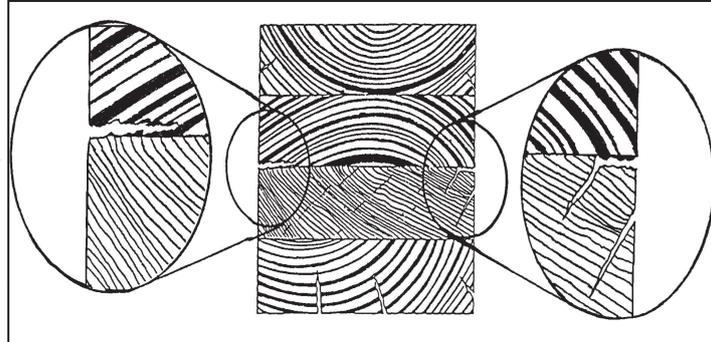

for loading parallel to the wide face of the laminations, checks may affect the shear strength of the beam their effect may be evaluated in the same manner as for sawn timber. Seasoning checks in bending members affect only the horizontal shear capacity.

In establishing allowable horizontal shear values, normal checking due to seasoning has been considered.

Checks are usually not of structural importance unless they are significant in depth, occur in the mid-height of the member near the supports, and the design of the member is governed by shear. If these conditions exist, the reduction in shear strength is directly proportional to the ratio of the depth of checks to the width of the bending member. Checks in columns are not of structural importance unless the

check develops into a split, thereby increasing the  $l/d$  ratio of the column.

## Additional information

While checking is not considered to be of structural significance, the reason for the checking and the means by which further checking may be minimized should be determined.

If there is concern regarding structural adequacy, advice can be obtained from engineers from the SmartFrame Design Centre or a structural engineer experienced and qualified in glued laminated timber technology should evaluate the significance of the checking.

The SmartFrame Technical Note - "Evaluation of Checking in Glued Laminated Timber (GLT)" gives detailed analysis of the modification to structural capacity as a result of severe checking.

## Storage and handling

1. Store SmartLam GLT15S's flat on a hard, dry surface
2. If surface isn't paved, the ground should be covered with a polythene film
3. Keep covered with waterproof material that allows bundles to "breathe"
4. Use bearers (bolsters) between the ground and the first bundle (4 metre max spacing)
5. Use 100 x 50 timber flat between bundles at same spacing as bolsters
6. Take great care to rewrap remaining material after opening bundles
7. Timber "grows" in thickness and depth when allowed to get wet....KEEP DRY!
8. Timber products with high MC has short term reduction in Characteristic Strengths .... KEEP DRY!
9. Under NO circumstances is stored SmartLam GLT15S to be in contact with the ground.

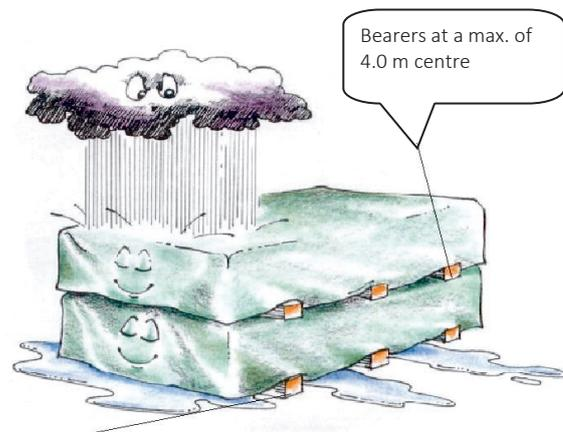

Use bearers to keep stacked material away from damp surfaces. Align bearer vertically

## LISTS OR TABLES AND CHARTS

Floor joists - Joist loads only	16
Floor bearers - floor loads only	17
Bearers - wall and roof loads - sheet and tiled roof	19
Single/upper storey lintels	
- Wind classification N1-N3	23
- Wind classification C1-C3	25
Lower storey lintels supporting load bearing walls and floors	27
Rafters/Roof beam - ceiling attached	
- Wind classification N1-N3	29
- Wind classification C1-C3	31
Rafters/Roof beam -no ceiling attached	
- Wind classification N1-N3	33
- Wind classification C1-C3	
Ridge or intermediate beam	
- Wind classification N1-N3	37
- Wind classification C1-C3	39
Verandah beam	
- single span wind classification N1-N3	41
- continuous span wind classification N1-N3	43
Verandah beam	
- single span wind classification C1-C3	45
- continuous span wind classification C1-C3	47
Hip or valley rafter	49

# Floor joists supporting floor loads only

Floor mass - 40 kg/m<sup>2</sup>

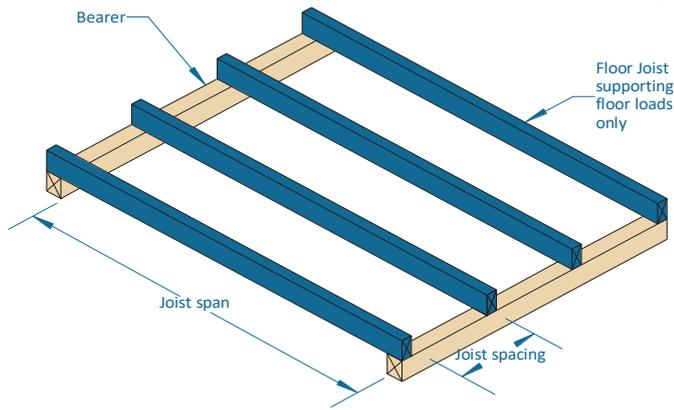

**EXAMPLE:**

domestic floor loads  
single span  
joist spacing = 450 mm  
joist span = 3500 mm

Enter single span table at 450 mm in joist spacing column, read down to a span equal to or greater than 3500 mm

**ADOPT:**

SmartLam GLT15S - 160x45

Loadings: permanent - self weight + 40 kg/m<sup>2</sup> + 0.5 kPa of the live load, live load - 1.5 kPa or floor point load of 1.8 kN

Joist Spacing (mm)	300	400	450	600	300	400	450	600
Size DxB (mm)	Recommended maximum floor joist span (mm)							
	Single Span				Continuous Span			
120x45	3400	2700	2500	2300	4000	3300	3000	2700
160x45	4300	3800	3600	3200	5000	4700	4400	3800
200x45	5100	4800	4600	4100	6000	5500	5400	4800
240x45	5900	5500	5300	4900	6800	6400	6200	5700
280x45	6600	6100	6000	5600	7700	7100	6900	6500
300x45	7000	6500	6300	5800	8100	7500	7300	6800
320x45	7300	6800	6600	6100	8500	7900	7700	7100
360x45	7900	7400	7200	6700	9300	8600	8400	7800
120x70	3800	3000	2900	2600	4400	3800	3500	3100
160x70	4700	4300	4000	3600	5500	5100	4900	4200
200x70	5600	5200	5000	4600	6500	6000	5800	5400
240x70	6400	5900	5800	5400	7400	6900	6700	6200
280x70	7100	6700	6500	6000	8300	7700	7500	7000
300x70	7400	7000	6800	6300	8800	8200	7900	7400
320x70	7700	7400	7200	6700	9200	8600	8300	7700
360x70	8400	8000	7800	7300	10600	9400	9100	8400
400x70	8900	8600	8400	7900	9100	10000	9800	9100
200x90	5900	5500	5400	5000	6900	6400	6200	5800
240x90	6600	6300	6200	5700	7900	7300	7200	6600
280x90	7400	7000	6900	6400	8900	8200	8000	7500
300x90	7700	7400	7200	6800	9300	8700	8500	7800
320x90	8000	7700	7500	7100	8300	9200	8900	8200
360x90	8600	8300	8200	7700	9000	10000	9700	9000
400x90	9200	8900	8700	8300	12000	9900	9900	9700

**NOTES:**

- Spans are suitable for solid timber, particle board and ply flooring. floor sheeting glued and nailed to joists will improve floor rigidity. Where heavy overlay material is to be applied, such as a mortar bed tiled or slate floor, the permanent load allowance should be increased to 1.2 kPa. A reduction of joist spacing may be used to accommodate this extra permanent load. A satisfactory result can be achieved by adopting the maximum spans for 600 mm and 450 mm spacing but installing the joists at 450 and 300 mm spacing respectively
- For beams which are continuous over two unequal spans, the design span and the 'resultant span description' depend upon the percentage span differences between the two spans as shown on page 2
- D = member depth, B = member breadth, NS = not suitable.
- End bearing lengths = 45 mm at end supports and 63 mm at internal supports for continuous members
- Not all sizes of SmartLam in this table are stocked in each state. Please check with your supplier before ordering.

# Floor bearers supporting floor loads only

Floor mass - 40 kg/m<sup>2</sup>

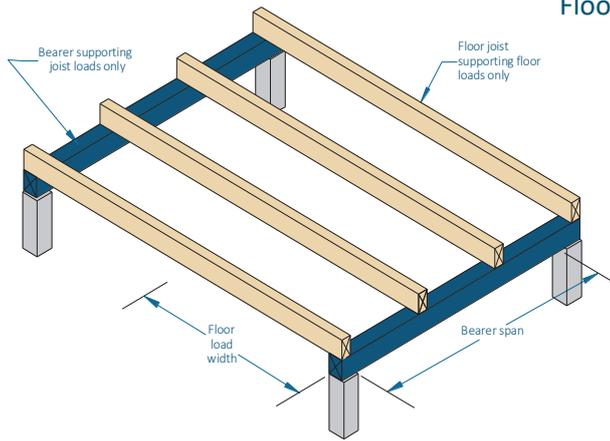

## EXAMPLE:

single span bearer = 4000 mm  
floor load width = 4000 mm

Enter single span table at 4200 mm in floor load width column, read down to a span equal to or greater than 4000 mm

## ADOPT:

SmartLam GLT15S - 360 x 45

Loadings: Permanent - self weight + 40 kg/m<sup>2</sup> + 0.6 kPa of the live load, live load - 1.5 kPa or floor point load of 1.8 kN

Floor load width (mm)	1200	1800	2400	3000	3600	4200	4800	5400	6000	6600
Size DxB (mm)	Maximum recommended SINGLE span bearer span (mm)									
120x45	2200	1900	1700	1600	1500	1400	1300	1300	1200	1100
160x45	2900	2600	2300	2100	2000	1900	1800	1700	1600	1500
200x45	3600	3200	2900	2700	2500	2400	2200	2100	2000	1900
240x45	4200	3700	3500	3200	3000	2800	2700	2600	2400	2300
280x45	4700	4200	3900	3700	3500	3300	3200	3000	2800	2700
300x45	4900	4400	4100	3900	3700	3600	3400	3200	3100	2900
320x45	5200	4700	4300	4100	3900	3700	3600	3400	3300	3100
360x45	5600	5100	4700	4500	4300	4100	3900	3800	3700	3500
400x45	6100	5500	5100	4800	4600	4400	4300	4100	4000	3900
120x70	2400	2100	1900	1800	1700	1600	1500	1400	1400	1300
160x70	3200	2800	2600	2400	2200	2100	2000	1900	1800	1800
200x70	3900	3500	3200	3000	2800	2600	2500	2400	2300	2200
240x70	4500	4100	3800	3600	3300	3200	3000	2900	2800	2700
280x70	5000	4600	4200	4000	3800	3700	3500	3400	3200	3100
300x70	5300	4800	4500	4200	4000	3900	3700	3600	3500	3300
320x70	5500	5000	4700	4400	4200	4000	3900	3800	3700	3600
360x70	6000	5500	5100	4800	4600	4400	4300	4100	4000	3900
400x70	6500	5900	5500	5200	5000	4800	4600	4500	4300	4200
440x70	7000	6300	5900	5600	5300	5100	5000	4800	4700	4500
200x90	4200	3800	3500	3200	3000	2900	2700	2600	2500	2400
240x90	4700	4300	4000	3800	3600	3400	3300	3100	3000	2900
280x90	5300	4800	4500	4200	4100	3900	3800	3600	3500	3400
300x90	5600	5100	4700	4500	4300	4100	4000	3800	3700	3600
320x90	5800	5300	5000	4700	4500	4300	4100	4000	3900	3800
360x90	6300	5800	5400	5100	4900	4700	4500	4400	4300	4100
400x90	6800	6200	5800	5500	5300	5100	4900	4700	4600	4500
440x90	7300	6700	6300	5900	5700	5400	5300	5100	5000	4800
200x120	4400	4000	3800	3500	3300	3100	3000	2900	2800	2700
240x120	5000	4600	4300	4100	3900	3700	3600	3400	3300	3200
280x120	5600	5200	4800	4600	4300	4200	4000	3900	3800	3700
300x120	5900	5400	5100	4800	4600	4400	4200	4100	4000	3900
320x120	6200	5700	5300	5000	4800	4600	4400	4300	4200	4100
360x120	6700	6200	5800	5500	5200	5000	4900	4700	4600	4400
400x120	7200	6600	6200	5900	5700	5400	5200	5100	4900	4800
440x120	7700	7100	6700	6300	6100	5800	5600	5500	5300	5200
240x140	5200	4800	4400	4200	4000	3900	3700	3600	3500	3400
280x140	5800	5300	5000	4700	4500	4300	4200	4000	3900	3800
300x140	6100	5600	5200	5000	4700	4600	4400	4300	4100	4000
320x140	6400	5900	5500	5200	5000	4800	4600	4500	4300	4200
360x140	6900	6400	6000	5700	5400	5200	5000	4900	4700	4600
400x140	7500	6900	6400	6100	5900	5600	5400	5300	5100	5000
440x140	8000	7300	6900	6600	6300	6000	5800	5700	5500	5400

## Floor bearers supporting floor loads only (Cont'd)

Floor mass - 40 kg/m<sup>2</sup>

Loadings: Permanent - self weight + 40 kg/m<sup>2</sup> + 0.6 kPa of the live load, live load - 1.5 kPa or floor point load of 1.8 kN

Floor load width (mm)	1200	1800	2400	3000	3600	4200	4800	5400	6000	6600
Size Dx B (mm)	Maximum recommended CONTINUOUS span bearer span (mm)									
120x45	2700	2300	1900	1700	1600	1400	1300	1300	1200	1100
160x45	3500	3000	2600	2300	2100	1900	1800	1700	1600	1500
200x45	4200	3800	3300	2900	2700	2400	2300	2100	2000	1900
240x45	4800	4400	3900	3500	3200	2900	2700	2600	2400	2300
280x45	5400	4900	4600	4100	3700	3400	3200	3000	2800 <sub>10</sub>	2700 <sub>15</sub>
300x45	5700	5200	4800	4400	4000	3700	3400 <sub>5</sub>	3200 <sub>10</sub>	3100 <sub>15</sub>	2900 <sub>20</sub>
320x45	6000	5400	5000	4700	4300	3900 <sub>5</sub>	3700 <sub>10</sub>	3400 <sub>15</sub>	3300 <sub>25</sub>	3100 <sub>30</sub>
360x45	6600	5900	5500	5200	4800 <sub>5</sub>	4400 <sub>15</sub>	4100 <sub>25</sub>	3900 <sub>30</sub>	3700 <sub>40</sub>	3500 <sub>55</sub>
400x45	7100	6400	6000	5600 <sub>5</sub>	5300 <sub>20</sub>	4900 <sub>30</sub>	4600 <sub>40</sub>	4300 <sub>55</sub>	4100 <sub>70</sub>	3900 <sub>75</sub>
120x70	3100	2700	2300	2000	1900	1700	1600	1500	1400	1300
160x70	3900	3500	3100	2700	2500	2300	2100	2000	1900	1800
200x70	4600	4100	3800	3400	3100	2900	2700	2500	2400	2300
240x70	5200	4700	4400	4100	3700	3500	3200	3000	2900	2700
280x70	5900	5300	4900	4700	4400	4000	3800	3500	3400	3200
300x70	6200	5600	5200	4900	4700	4300	4000	3800	3600	3400
320x70	6500	5900	5500	5200	4900	4600	4300	4000	3800	3600
360x70	7100	6400	6000	5700	5400	5200	4800	4500	4300 <sub>5</sub>	4100 <sub>10</sub>
400x70	7700	6900	6500	6100	5800	5600	5400 <sub>5</sub>	5100 <sub>10</sub>	4800 <sub>15</sub>	4500 <sub>25</sub>
440x70	8300	7500	6900	6600	6300	6000 <sub>5</sub>	5800 <sub>15</sub>	5600 <sub>25</sub>	5300 <sub>30</sub>	5000 <sub>35</sub>
200x90	4900	4400	4100	3900	3500	3300	3000	2900	2700	2600
240x90	5600	5000	4700	4400	4200	3900	3700	3400	3300	3100
280x90	6300	5700	5300	5000	4800	4600	4300	4000	3800	3600
300x90	6600	6000	5500	5200	5000	4800	4600	4300	4100	3900
320x90	6900	6300	5800	5500	5300	5100	4900	4600	4300	4100
360x90	7600	6800	6400	6000	5800	5500	5400	5100	4900	4600
400x90	8200	7400	6900	6500	6200	6000	5800	5600	5400 <sub>5</sub>	5100 <sub>10</sub>
440x90	8800	7900	7400	7000	6700	6400	6200	6000 <sub>5</sub>	5900 <sub>10</sub>	5700 <sub>20</sub>
200x120	5200	4700	4400	4200	4000	3800	3500	3300	3100	3000
240x120	6000	5400	5000	4800	4600	4400	4200	4000	3800	3600
280x120	6700	6100	5700	5400	5100	4900	4800	4600	4400	4200
300x120	7100	6400	6000	5600	5400	5200	5000	4900	4700	4500
320x120	7500	6700	6300	5900	5700	5400	5300	5100	5000	4800
360x120	8200	7300	6800	6500	6200	6000	5800	5600	5400	5300
400x120	8800	7900	7400	7000	6700	6400	6200	6000	5900	5800
440x120	9500	8500	7900	7500	7200	6900	6700	6500	6300	6200
240x140	6200	5600	5200	5000	4700	4600	4400	4300	4100	3900
280x140	7000	6300	5900	5600	5300	5100	4900	4800	4700	4500
300x140	7400	6700	6200	5900	5600	5400	5200	5100	4900	4800
320x140	7800	7000	6500	6200	5900	5700	5500	5300	5200	5000
360x140	8500	7600	7100	6700	6400	6200	6000	5800	5700	5500
400x140	9200	8300	7700	7300	7000	6700	6500	6300	6100	6000
440x140	9900	8900	8300	7800	7500	7200	7000	6800	6600	6400

### NOTES:

1. D = member depth, B = member breadth, NS = not suitable.
2. End bearing lengths = 70 mm at end supports and 90 mm at internal supports for continuous members. Subscript values indicate the minimum additional bearing length where required to be greater than 70 mm at end supports and 90 mm at internal supports.
3. Restraint value for slenderness calculations is 600 mm. (floor joist centres at 600 mm max)
4. Not all sizes of SmartLam GLT15S in this table are stocked in each state. Please check with your supplier before ordering
5. Table does not list all available SmartLam GLT15S sizes. See page 11 for full list of sizes

# Floor bearers supporting single storey load bearing wall - sheet and tiled roof

## Single span

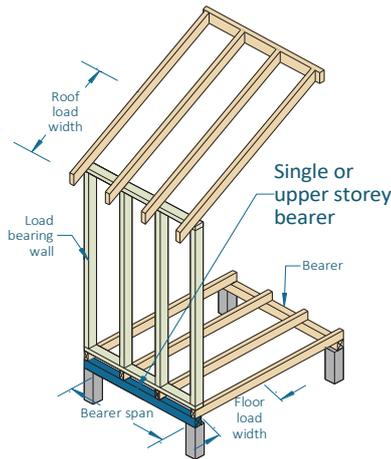

Floor mass - 40 kg/m<sup>2</sup>

### EXAMPLE:

Sheet roof - 40 kg/m<sup>2</sup>  
 floor load width = 2000 mm  
 roof load width = 1950 mm  
 bearer span = 3000 mm (single span)

Enter single span table at 2400 mm in floor load width column, 4500 roof load width column, read down to a span equal to or greater than 3000 mm in the 40 kg/m<sup>2</sup> row

### ADOPT:

**SmartLam GLT15S - 280 x 45**

Floor load width (mm)		1200			2400			4800		
Roof load width (mm)		1500	4500	7500	1500	4500	7500	1500	4500	7500
Size DxB (mm)	Roof Mass (kg/m <sup>2</sup> )	Maximum SINGLE span bearer span (mm)								
120x45	40	1600	1400	1200	1400	1300	1200	1200	1100	1000
	90	1500	1200	1000	1300	1100	1000	1200	1000	NS
160x45	40	2200	1900	1600	1900	1700	1600	1600	1500	1400
	90	2000	1600	1400	1800	1500	1300	1600	1400	1300
200x45	40	2700	2300	2100	2400	2200	2000	2000	1900	1800
	90	2500	2000	1800	2300	1900	1700	2000	1700	1600
240x45	40	3300	2800	2500	2900	2600	2400	2500	2300	2100
	90	3000	2500	2100	2700	2300	2000	2400	2100	1900
280x45	40	3800	3300	2900	3400	3000	2800	2900	2700	2500
	90	3500	2900	2500	3200	2700	2400	2800	2500	2200
300x45	40	4000	3500	3100	3600	3300	2900	3100	2900	2700
	90	3700	3100	2700	3400	2900	2600	3000	2600	2400
320x45	40	4100	3700	3300	3800	3500	3100	3300	3100	2800
	90	3900	3300	2900	3600	3100	2700	3200	2800	2600
360x45	40	4500	4100	3700	4200	3800	3500	3700	3400	3200
	90	4300	3700	3200	4000	3500	3100	3600	3200	2900
400x45	40	4900	4400	4000	4500	4100	3800	4000	3800	3600
	90	4600	4000	3600	4300	3800	3400	3900	3500	3200
120x70	40	1800	1600	1400	1600	1400	1300	1300	1300	1200
	90	1700	1300	1200	1500	1300	1100	1300	1100	1000
160x70	40	2400	2100	1800	2100	1900	1700	1800	1700	1600
	90	2200	1800	1600	2000	1700	1500	1700	1500	1400
200x70	40	3000	2600	2300	2700	2400	2200	2300	2100	2000
	90	2800	2300	2000	2500	2100	1900	2200	1900	1800
240x70	40	3600	3100	2800	3200	2900	2600	2700	2500	2400
	90	3400	2700	2400	3100	2600	2300	2600	2300	2100
280x70	40	4100	3600	3200	3700	3400	3100	3200	3000	2800
	90	3800	3200	2800	3600	3000	2700	3100	2700	2500
300x70	40	4300	3800	3500	3900	3600	3300	3400	3200	3000
	90	4000	3400	3000	3800	3200	2900	3300	2900	2700
320x70	40	4500	4000	3700	4100	3800	3500	3600	3400	3200
	90	4200	3600	3200	3900	3500	3100	3500	3100	2900
360x70	40	4900	4400	4000	4500	4100	3800	4000	3800	3600
	90	4600	4000	3600	4300	3800	3400	3900	3500	3200
400x70	40	5300	4800	4300	4900	4500	4200	4300	4100	3900
	90	5000	4300	3900	4700	4100	3800	4200	3800	3600
440x70	40	5700	5100	4700	5200	4800	4500	4600	4400	4200
	90	5400	4600	4200	5000	4400	4000	4500	4100	3800
200x90	40	3300	2800	2500	2900	2600	2400	2500	2300	2100
	90	3000	2500	2100	2800	2300	2100	2400	2100	1900

# Floor bearers supporting single storey load bearing wall - sheet and tiled roof Single span (cont'd)

Floor mass - 40 kg/m<sup>2</sup>

Floor load width (mm)		1200			2400			4800		
Roof load width (mm)		1500	4500	7500	1500	4500	7500	1500	4500	7500
Size DxB (mm)	Roof Mass (kg/m <sup>2</sup> )	Maximum SINGLE span bearer span (mm)								
240x90	40	3800	3400	3000	3500	3100	2900	3000	2800	2600
	90	3600	3000	2600	3300	2800	2500	2900	2600	2300
280x90	40	4300	3900	3500	4000	3600	3300	3500	3200	3000
	90	4100	3500	3000	3800	3300	2900	3400	3000	2700
300x90	40	4500	4100	3700	4200	3800	3600	3700	3500	3200
	90	4300	3700	3200	4000	3500	3100	3600	3200	2900
320x90	40	4800	4300	3900	4400	4000	3700	3900	3700	3500
	90	4500	3900	3500	4200	3700	3300	3800	3400	3100
360x90	40	5200	4700	4300	4800	4400	4100	4200	4000	3800
	90	4900	4200	3800	4600	4000	3700	4100	3800	3500
400x90	40	5600	5000	4600	5200	4800	4400	4600	4300	4100
	90	5300	4600	4100	4900	4400	4000	4400	4100	3800
440x90	40	6000	5400	5000	5500	5100	4800	4900	4700	4400
	90	5700	4900	4400	5300	4700	4300	4800	4400	4100
240x120	40	4100	3700	3300	3800	3500	3100	3300	3000	2800
	90	3900	3300	2800	3600	3100	2700	3200	2800	2600
280x120	40	4600	4100	3800	4200	3900	3600	3700	3600	3300
	90	4400	3700	3300	4100	3600	3200	3700	3300	3000
300x120	40	4900	4400	4000	4500	4100	3800	3900	3700	3600
	90	4600	3900	3600	4300	3800	3400	3800	3500	3200
320x120	40	5100	4600	4200	4700	4300	4000	4100	3900	3700
	90	4800	4100	3700	4500	4000	3600	4000	3700	3400
360x120	40	5500	5000	4600	5100	4700	4400	4500	4300	4100
	90	5200	4500	4100	4900	4300	4000	4400	4000	3800
400x120	40	6000	5400	5000	5500	5100	4700	4900	4700	4400
	90	5700	4900	4400	5300	4700	4300	4800	4400	4100
440x120	40	6400	5800	5300	5900	5500	5100	5300	5000	4700
	90	6100	5300	4700	5700	5000	4600	5100	4700	4400
240x140	40	4300	3800	3500	3900	3600	3300	3400	3200	3000
	90	4000	3400	3000	3800	3300	2900	3300	3000	2700
280x140	40	4800	4300	3900	4400	4100	3800	3900	3700	3500
	90	4500	3900	3500	4200	3700	3400	3800	3500	3100
300x140	40	5000	4500	4100	4600	4300	4000	4100	3900	3700
	90	4800	4100	3700	4400	3900	3600	4000	3700	3400
320x140	40	5300	4800	4400	4900	4500	4200	4300	4100	3900
	90	5000	4300	3900	4700	4100	3800	4200	3800	3600
360x140	40	5700	5200	4800	5300	4900	4600	4700	4500	4200
	90	5400	4700	4200	5100	4500	4100	4600	4200	3900
400x140	40	6200	5600	5100	5700	5300	4900	5100	4800	4600
	90	5900	5100	4600	5500	4900	4500	5000	4500	4200
440x140	40	6600	6000	5500	6100	5700	5300	5400	5200	4900
	90	6300	5400	4900	5900	5200	4800	5300	4900	4600

## NOTES:

1. D = member depth, B = member breadth, NS = not suitable.
2. The above table was based on a maximum DL of 40 kg/m<sup>2</sup>, total ground floor mass of 40 kg/m<sup>2</sup>, total wall mass of 37 kg/m<sup>2</sup>, floor live load of 1.5 kPa, floor point load of 1.8 kN
3. The above table was based on a wall height of 2700 mm
4. End bearing lengths = 70 mm at end supports and 90 mm at internal supports for continuous members. Subscript values indicate the minimum additional bearing length where required to be greater than 70 mm at end supports and 90 mm at internal supports
5. Restraint value for slenderness calculations is 600 mm
6. Not all sizes of SmartLam GLT15S in this table are stocked in each state. Please check with your supplier before ordering.
7. Table does not list all available SmartLam GLT15S sizes. See page 11 for full list of sizes

# Floor bearers supporting single storey load bearing wall - sheet and tiled roof Continuous span

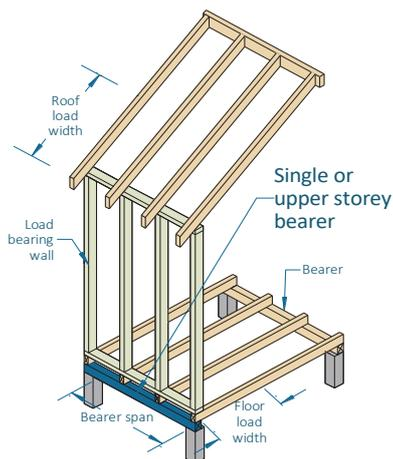

Floor mass - 40 kg/m<sup>2</sup>

### EXAMPLE:

Sheet roof - 40 kg/m<sup>2</sup>  
 floor load width = 2000 mm  
 roof load width = 1950 mm  
 bearer span = 3000 mm (Continuous span)

Enter single span table at 2400 mm in floor load width column, 4500 roof load width column, read down to a span equal to or greater than 3000 mm in the 40 kg/m<sup>2</sup> row

### ADOPT:

SmartLam GLT15S - 240 x 45

Floor load width (mm)		1200			2400			4800		
Roof load width (mm)		1500	4500	7500	1500	4500	7500	1500	4500	7500
Size DxB (mm)	Roof Mass (kg/m <sup>2</sup> )	Maximum CONTINUOUS span bearer span (mm)								
120x45	40	2200	1800	1500	1700	1500	1400	1300	1200	1100
	90	2000	1500	1200	1600	1400	1100	1200	1100	1000
160x45	40	2900	2500	2100	2300	2100	1900	1700	1600	1500
	90	2700	2000	1600	2200	1800	1500	1600	1500	1400
200x45	40	3700	3100	2600	2900	2600	2300	2100	2000	1900
	90	3400	2500	2000	2700	2300	1900	2100	1900	1700
240x45	40	4200	3700	3100	3500	3100	2800	2600	2400	2300
	90	4000	3000	2500	3300	2800	2300	2500	2300	2100 <sub>10</sub>
280x45	40	4700	4200	3600	4000	3700	3300	3000 <sub>5</sub>	2800 <sub>10</sub>	2700 <sub>15</sub>
	90	4500	3500	2900 <sub>10</sub>	3800	3200	2700 <sub>15</sub>	2900 <sub>5</sub>	2600 <sub>15</sub>	2400 <sub>25</sub>
300x45	40	5000	4500	3900	4300	3900	3500	3200 <sub>10</sub>	3000 <sub>15</sub>	2900 <sub>25</sub>
	90	4700	3800	3100 <sub>15</sub>	4100	3500 <sub>5</sub>	2900 <sub>20</sub>	3100 <sub>15</sub>	2800 <sub>25</sub>	2600 <sub>35</sub>
320x45	40	5200	4700	4100	4600	4200	3800 <sub>10</sub>	3400 <sub>15</sub>	3200 <sub>25</sub>	3000 <sub>35</sub>
	90	4900	4000	3300 <sub>20</sub>	4400	3700 <sub>10</sub>	3100 <sub>30</sub>	3300 <sub>20</sub>	3000 <sub>35</sub>	2700 <sub>55</sub>
360x45	40	5700	5100	4600 <sub>5</sub>	5200	4700 <sub>10</sub>	4200 <sub>20</sub>	3900 <sub>35</sub>	3600 <sub>40</sub>	3400 <sub>60</sub>
	90	5400	4500 <sub>10</sub>	3700 <sub>35</sub>	4900 <sub>5</sub>	4100 <sub>20</sub>	3500 <sub>55</sub>	3800 <sub>35</sub>	3400 <sub>60</sub>	3100 <sub>75</sub>
400x45	40	6200	5500	5100 <sub>20</sub>	5600 <sub>10</sub>	5200 <sub>20</sub>	4700 <sub>35</sub>	4300 <sub>55</sub>	4100 <sub>70</sub>	3800 <sub>75</sub>
	90	5800	5000 <sub>25</sub>	4100 <sub>65</sub>	5400 <sub>15</sub>	4600 <sub>35</sub>	3900 <sub>75</sub>	4200 <sub>65</sub>	3800 <sub>80</sub>	3400 <sub>95</sub>
120x70	40	2500	2100	1800	2000	1800	1600	1500	1400	1300
	90	2300	1800	1400	1900	1600	1300	1400	1300	1200
160x70	40	3300	2800	2400	2700	2400	2200	2000	1900	1800
	90	3000	2400	1900	2600	2200	1800	1900	1800	1600
200x70	40	4000	3600	3000	3400	3100	2800	2500	2400	2200
	90	3700	3000	2400	3200	2700	2300	2400	2200	2000
240x70	40	4600	4100	3600	4100	3700	3300	3000	2900	2700
	90	4300	3600	2900	3900	3200	2700	2900	2700	2400
280x70	40	5100	4600	4200	4700	4300	3900	3500	3300	3100
	90	4800	4100	3400	4500	3800	3200	3400	3100	2800
300x70	40	5400	4800	4400	4900	4500	4100	3800	3600	3400
	90	5100	4400	3600	4700	4100	3400	3700	3300	3000 <sub>5</sub>
320x70	40	5600	5100	4600	5200	4800	4400	4000	3800	3600
	90	5300	4600	3900	5000	4300	3600	3900	3600	3200 <sub>10</sub>
360x70	40	6200	5500	5100	5700	5200	4800	4500	4300 <sub>5</sub>	4000 <sub>10</sub>
	90	5800	5000	4300 <sub>5</sub>	5400	4800	4100 <sub>10</sub>	4400 <sub>5</sub>	4000 <sub>15</sub>	3600 <sub>25</sub>
400x70	40	6700	6000	5500	6100	5600	5200	5000 <sub>10</sub>	4800 <sub>20</sub>	4500 <sub>25</sub>
	90	6300	5400	4800 <sub>15</sub>	5900	5200	4500 <sub>25</sub>	4900 <sub>15</sub>	4400 <sub>25</sub>	4000 <sub>40</sub>
440x70	40	7200	6400	5900	6600	6100	5600 <sub>5</sub>	5500 <sub>25</sub>	5200 <sub>30</sub>	4900 <sub>35</sub>
	90	6800	5800	5200 <sub>25</sub>	6300	5600 <sub>10</sub>	5000 <sub>35</sub>	5400 <sub>25</sub>	4900 <sub>40</sub>	4400 <sub>65</sub>
200x90	40	4200	3800	3400	3800	3500	3100	2800	2700	2500
	90	4000	3400	2700	3700	3100	2600	2800	2500	2300

# Floor bearers supporting single storey load bearing wall - sheet and tiled roof Continuous span (cont'd)

Floor mass - 40 kg/m<sup>2</sup>

Floor load width (mm)		1200			2400			4800		
Roof load width (mm)		1500	4500	7500	1500	4500	7500	1500	4500	7500
Size DxB (mm)	Roof Mass (kg/m <sup>2</sup> )	Maximum CONTINUOUS span bearer span (mm)								
240x90	40	4800	4300	4000	4400	4100	3800	3400	3200	3000
	90	4600	3900	3300	4300	3700	3100	3300	3000	2700
280x90	40	5400	4900	4500	5000	4600	4300	4000	3800	3600
	90	5100	4400	3800	4800	4200	3600	3900	3500	3200
300x90	40	5700	5100	4700	5200	4800	4500	4300	4000	3800
	90	5400	4600	4100	5000	4400	3900	4200	3800	3400
320x90	40	6000	5400	4900	5500	5100	4700	4600	4300	4100
	90	5600	4900	4400	5300	4700	4100	4400	4000	3700
360x90	40	6500	5900	5400	6000	5500	5200	5100	4800	4600
	90	6200	5300	4800	5800	5100	4600	5000	4500	4100 <sub>10</sub>
400x90	40	7100	6300	5800	6500	6000	5600	5700	5400 <sub>5</sub>	5100 <sub>10</sub>
	90	6700	5700	5200	6200	5500	5000 <sub>10</sub>	5500	5000 <sub>10</sub>	4600 <sub>20</sub>
440x90	40	7600	6800	6200	7000	6400	6000	6200 <sub>5</sub>	5900 <sub>15</sub>	5600 <sub>20</sub>
	90	7200	6200	5600 <sub>5</sub>	6700	5900	5400 <sub>15</sub>	6000 <sub>10</sub>	5500 <sub>20</sub>	5000 <sub>35</sub>
240x120	40	5200	4700	4300	4800	4400	4100	3900	3700	3500
	90	4900	4200	3800	4600	4000	3600	3800	3500	3200
280x120	40	5800	5200	4800	5300	4900	4600	4600	4400	4100
	90	5500	4700	4300	5100	4500	4100	4500	4100	3700
300x120	40	6100	5500	5000	5600	5200	4800	4900	4700	4400
	90	5800	5000	4500	5400	4800	4400	4800	4300	4000
320x120	40	6400	5800	5300	5900	5400	5100	5200	5000	4700
	90	6100	5200	4700	5700	5000	4600	5100	4600	4200
360x120	40	7000	6300	5800	6400	5900	5500	5700	5400	5100
	90	6600	5700	5100	6200	5500	5000	5600	5100	4800
400x120	40	7600	6800	6200	7000	6400	6000	6200	5900	5600
	90	7100	6100	5600	6700	5900	5400	6000	5500	5100 <sub>5</sub>
440x120	40	8100	7300	6700	7500	6900	6400	6600	6300	6000
	90	7700	6600	6000	7100	6300	5800	6500	5900	5500 <sub>10</sub>
240x140	40	5400	4800	4400	4900	4600	4200	4300	4000	3800
	90	5100	4400	3900	4700	4200	3800	4100	3800	3400
280x140	40	6000	5400	5000	5500	5100	4800	4900	4700	4400
	90	5700	4900	4400	5300	4700	4300	4800	4400	4000
300x140	40	6300	5700	5200	5800	5400	5000	5200	4900	4700
	90	6000	5200	4700	5600	5000	4500	5000	4600	4300
320x140	40	6600	6000	5500	6100	5600	5300	5400	5100	4900
	90	6300	5400	4900	5900	5200	4800	5300	4800	4500
360x140	40	7200	6500	6000	6700	6200	5700	5900	5600	5300
	90	6900	5900	5300	6400	5700	5200	5800	5300	4900
400x140	40	7800	7000	6500	7200	6700	6200	6400	6100	5800
	90	7400	6400	5800	6900	6100	5600	6200	5700	5300
440x140	40	8400	7500	6900	7700	7100	6700	6900	6500	6200
	90	7900	6800	6200	7400	6600	6000	6700	6100	5700

## NOTES:

1. D = member depth, B = member breadth, NS = not suitable.
2. The above table was based on a maximum DL of 40 kg/m<sup>2</sup>, total ground floor mass of 40 kg/m<sup>2</sup>, total wall mass of 37 kg/m<sup>2</sup>, floor live load of 1.5 kPa, floor point load of 1.8 kN
3. The above table was based on a wall height of 2700 mm
4. End bearing lengths = 70 mm at end supports and 90 mm at internal supports for continuous members. Subscript values indicate the minimum additional bearing length where required to be greater than 70 mm at end supports and 90 mm at internal supports
5. Restraint value for slenderness calculations is 600 mm
6. Not all sizes of SmartLam GLT15S in this table are stocked in each state. Please check with your supplier before ordering.
7. Table does not list all available SmartLam GLT15S sizes. See page 11 for full list of sizes

# Single span lintels in single/upper storey walls AS 4055 classification N1, N2 and N3

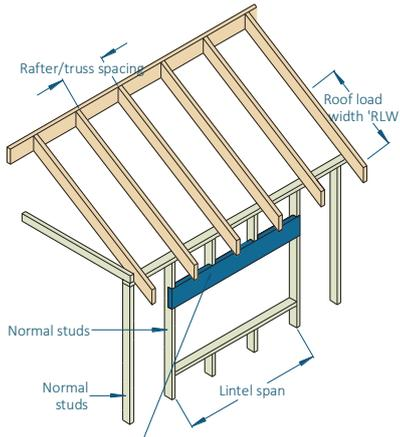

Single/Upper storey lintel

### EXAMPLE:

wind speed = N3  
sheet roof - 40 kg/m<sup>2</sup>  
roof load width = 3900 mm  
rafter/truss spacing = 900 mm  
lintel span = 3500 mm

Enter span table at 4500 roof load width column, rafter/truss spacing 900 mm, and read down to a span equal to or greater than 3500 mm in the 40 kg/m<sup>2</sup> row

### ADOPT:

SmartLam GLT15S - 280 x 45

Roof load width (mm)		1500		3000		4500		6000		7500	
Rafter/truss spacing (mm)		900	1200	900	1200	900	1200	900	1200	900	1200
Size DxB (mm)	Roof mass (kg/m <sup>2</sup> )	Maximum recommended lintel span (mm)									
120x45	40	2600	2700	2100	2000	1800	1700	1500	1300	1300	1000
	90	2100	2000	1600	1500	1400	1100	1100	NS	NS	NS
160x45	40	3300	3300	2700	2800	2300	2300	2100	2100	1900	1700
	90	2700	2700	2100	2100	1800	1800	1600	1500	1500	1100
200x45	40	3900	3900	3300	3300	2900	2900	2600	2700	2400	2400
	90	3300	3300	2600	2700	2300	2300	2100	2000	1900 <sub>5</sub>	1700 <sub>5</sub>
240x45	40	4500	4500	3800	3700	3400	3300	3100	3100	2800	2900 <sub>5</sub>
	90	3800	3700	3200	3100	2800	2800	2500	2500 <sub>10</sub>	2300 <sub>10</sub>	2300 <sub>10</sub>
280x45	40	5000	5100	4200	4200	3800	3800	3500	3400	3200 <sub>5</sub>	3200 <sub>5</sub>
	90	4200	4200	3500	3500	3200	3200	2900 <sub>5</sub>	2900 <sub>15</sub>	2700 <sub>10</sub>	2700 <sub>20</sub>
300x45	40	5300	5300	4400	4400	4000	4000	3600	3600	3400 <sub>5</sub>	3400 <sub>5</sub>
	90	4400	4400	3700	3700	3300	3300	3100 <sub>5</sub>	3100 <sub>10</sub>	2900 <sub>10</sub>	2900 <sub>30</sub>
320x45	40	5500	5600	4700	4700	4200	4200	3800	3800	3600 <sub>10</sub>	3600 <sub>5</sub>
	90	4700	4600	3900	3900	3500	3500	3200 <sub>15</sub>	3200 <sub>10</sub>	3000 <sub>15</sub>	3000 <sub>25</sub>
360x45	40	6100	6000	5100	5100	4600	4500	4200 <sub>5</sub>	4200 <sub>10</sub>	3900 <sub>10</sub>	3900 <sub>5</sub>
	90	5100	5100	4300	4300	3800 <sub>5</sub>	3800	3500 <sub>20</sub>	3500 <sub>10</sub>	3300 <sub>30</sub>	3300 <sub>25</sub>
400x45	40	6500	6500	5500	5500	4900	4900	4500 <sub>5</sub>	4500 <sub>5</sub>	4200 <sub>15</sub>	4200 <sub>20</sub>
	90	5500	5500	4600	4600	4200 <sub>5</sub>	4200 <sub>5</sub>	3800 <sub>20</sub>	3800 <sub>15</sub>	3600 <sub>35</sub>	3600 <sub>25</sub>
120x70	40	2900	2900	2300	2300	2000	1900	1700	1700	1600	1400
	90	2200	2300	1800	1700	1500	1400	1400	1100	1100	NS
160x70	40	3600	3600	3000	3000	2600	2600	2300	2300	2100	2100
	90	3000	3000	2400	2400	2100	2000	1900	1800	1700	1600
200x70	40	4200	4200	3500	3500	3200	3200	2900	2900	2600	2700
	90	3500	3500	3000	3000	2500	2600	2300	2300	2100	2100
240x70	40	4800	4800	4100	4100	3600	3600	3300	3300	3100	3100
	90	4100	4000	3400	3400	3100	3000	2800	2800	2500	2600
280x70	40	5400	5400	4600	4500	4100	4100	3800	3700	3500	3500
	90	4500	4500	3800	3800	3400	3400	3200	3200	3000	3000 <sub>5</sub>
300x70	40	5700	5700	4800	4800	4300	4300	4000	3900	3700	3700
	90	4800	4800	4000	4000	3600	3600	3300	3300	3200 <sub>5</sub>	3100 <sub>5</sub>
320x70	40	5900	5900	5000	5000	4500	4500	4100	4100	3900	3900
	90	5000	5000	4200	4200	3800	3800	3500	3500	3300 <sub>5</sub>	3300 <sub>5</sub>
360x70	40	6400	6400	5500	5500	4900	4900	4500	4500	4200	4200
	90	5500	5500	4600	4600	4200	4200	3800	3800	3600 <sub>5</sub>	3600 <sub>5</sub>
400x70	40	7000	6900	5900	5900	5300	5300	4900	4900	4600	4600
	90	5900	5900	5000	5000	4500	4500	4200	4200	3900 <sub>10</sub>	3900 <sub>5</sub>
440x70	40	7400	7400	6300	6300	5700	5700	5300	5300	4900	4900 <sub>5</sub>
	90	6300	6300	5400	5400	4800	4800	4500 <sub>5</sub>	4500 <sub>10</sub>	4200 <sub>10</sub>	4200 <sub>10</sub>

## Single span lintels in single/upper storey walls AS 4055 classification N1, N2 and N3 (Cont'd)

Roof load width (mm)		1500		3000		4500		6000		7500	
Rafter/truss spacing (mm)		900	1200	900	1200	900	1200	900	1200	900	1200
Size DxB (mm)	Roof mass (kg/m <sup>2</sup> )	Maximum recommended lintel span (mm)									
200x90	40	4500	4500	3800	3700	3400	3300	3100	3100	2900	2900
	90	3800	3700	3200	3100	2800	2800	2500	2600	2300	2300
240x90	40	5100	5100	4300	4300	3900	3800	3500	3500	3300	3300
	90	4300	4300	3600	3600	3300	3200	3000	3000	2800	2800
280x90	40	5700	5700	4800	4800	4300	4300	4000	4000	3700	3700
	90	4800	4800	4100	4100	3600	3600	3400	3400	3200	3200
300x90	40	6000	5900	5100	5100	4600	4500	4200	4200	3900	3900
	90	5100	5100	4300	4300	3900	3800	3600	3500	3300	3300
320x90	40	6200	6200	5300	5300	4800	4800	4400	4400	4100	4100
	90	5300	5300	4500	4500	4000	4000	3700	3700	3500	3500
360x90	40	6800	6800	5800	5800	5200	5200	4800	4800	4500	4500
	90	5800	5800	4900	4900	4400	4400	4100	4100	3800	3800
400x90	40	7300	7300	6300	6200	5600	5600	5200	5200	4900	4900
	90	6200	6200	5300	5300	4800	4800	4400	4400	4200	4200
440x90	40	7800	7800	6700	6700	6000	6000	5600	5600	5200	5200
	90	6700	6700	5700	5700	5100	5100	4800	4700 <sub>5</sub>	4500 <sub>5</sub>	4500 <sub>10</sub>
200x120	40	4700	4700	4000	4000	3600	3600	3300	3300	3100	3100
	90	4000	4000	3400	3400	3000	3000	2700	2800	2500	2600
240x120	40	5400	5400	4600	4600	4100	4100	3800	3800	3600	3500
	90	4600	4600	3900	3900	3500	3500	3200	3200	3000	3000
280x120	40	6000	6000	5100	5200	4600	4600	4300	4300	4000	4000
	90	5100	5100	4300	4300	3900	3900	3600	3600	3400	3400
300x120	40	6300	6300	5400	5400	4900	4900	4500	4500	4200	4200
	90	5400	5400	4600	4600	4100	4100	3800	3800	3600	3600
320x120	40	6600	6600	5700	5700	5100	5100	4700	4700	4400	4400
	90	5600	5600	4800	4800	4300	4300	4000	4000	3800	3800
360x120	40	7100	7100	6200	6100	5600	5600	5100	5200	4800	4800
	90	6100	6100	5200	5200	4700	4700	4400	4400	4100	4100
400x120	40	7700	7700	6600	6700	6000	6000	5600	5600	5200	5200
	90	6600	6600	5600	5700	5100	5100	4700	4700	4500	4500
440x120	40	8200	8100	7100	7100	6400	6400	6000	5900	5600	5600
	90	7100	7100	6100	6100	5500	5500	5100	5100	4800	4800
240x140	40	5600	5600	4800	4800	4300	4300	4000	3900	3700	3700
	90	4700	4700	4000	4000	3600	3600	3300	3300	3200	3100
280x140	40	6200	6200	5300	5300	4800	4800	4400	4400	4100	4100
	90	5300	5300	4500	4500	4100	4100	3800	3700	3500	3500
300x140	40	6500	6500	5600	5600	5000	5100	4700	4600	4400	4400
	90	5600	5600	4700	4700	4300	4300	4000	4000	3700	3700
320x140	40	6800	6800	5800	5800	5300	5300	4900	4900	4600	4600
	90	5800	5800	5000	5000	4500	4500	4200	4200	3900	3900
360x140	40	7300	7300	6300	6400	5800	5700	5300	5300	5000	5000
	90	6300	6300	5400	5400	4900	4900	4500	4500	4300	4300
400x140	40	7900	7800	6800	6900	6200	6200	5800	5700	5400	5400
	90	6800	6800	5800	5900	5300	5300	4900	4900	4600	4600
440x140	40	8400	8300	7300	7300	6600	6700	6200	6200	5800	5800
	90	7300	7300	6300	6300	5700	5700	5300	5300	5000	5000

### NOTES:

1. D = member depth, B = member breadth, NS = not suitable.
2. Minimum bearing length = 35 mm at end supports. Subscript values indicate the minimum additional bearing length where required to be greater than 35 mm
3. Restraint value for slenderness calculations is 600 mm
4. Not all sizes of SmartLam GLT15S in this table are stocked in each state. Please check with your supplier before ordering
5. Table does not list all available SmartLam GLT15S sizes. See page 11 for full list of sizes

# Single span lintels in single/upper storey walls AS 4055 classification C1, C2 and C3

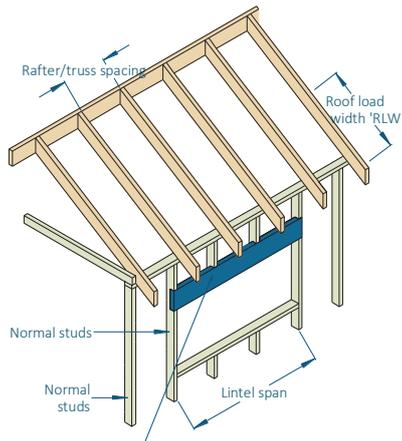

Single/Upper storey lintel

### EXAMPLE:

wind speed = C3  
sheet roof - 40 kg/m<sup>2</sup>  
roof load width = 3900 mm  
rafter/truss spacing = 900 mm  
lintel span = 3500 mm

Enter span table at 4500 roof load width column, rafter/truss spacing 900 mm, and read down to a span equal to or greater than 3500 mm in the 40 kg/m<sup>2</sup> row

### ADOPT:

SmartLam GLT15S - 360 x 45

Roof load width (mm)		1500		3000		4500		6000		7500	
Rafter/truss spacing (mm)		900	1200	900	1200	900	1200	900	1200	900	1200
Size DxB (mm)	Roof mass (kg/m <sup>2</sup> )	Maximum recommended lintel span (mm)									
120x45	40	2000	1800	1200	NS	NS	NS	NS	NS	NS	NS
	90	2000	1800	1200	NS	NS	NS	NS	NS	NS	NS
160x45	40	2600	2600	1800	1600	1200	NS	NS	NS	NS	NS
	90	2600	2600	1800	1600	1200	NS	NS	NS	NS	NS
200x45	40	3400	3200	2300	2300	1900 <sub>5</sub>	1500 <sub>5</sub>	1300 <sub>5</sub>	NS	NS	NS
	90	3300	3300	2300	2300	1900 <sub>10</sub>	1600 <sub>10</sub>	1300 <sub>10</sub>	NS	NS	NS
240x45	40	4100	4000	2800	2800 <sub>5</sub>	2200 <sub>10</sub>	2200 <sub>5</sub>	2000 <sub>15</sub>	1500	1300 <sub>15</sub>	NS
	90	3800	3700	2800	2800 <sub>10</sub>	2200 <sub>15</sub>	2200 <sub>10</sub>	2000 <sub>25</sub>	1500 <sub>30</sub>	1300 <sub>25</sub>	NS
280x45	40	4800	4800	3400	3200	2600 <sub>5</sub>	2700 <sub>15</sub>	2300 <sub>25</sub>	1800 <sub>15</sub>	1600 <sub>10</sub>	1500 <sub>5</sub>
	90	4200	4200	3400 <sub>5</sub>	3200 <sub>5</sub>	2600 <sub>10</sub>	2700 <sub>25</sub>	2300 <sub>35</sub>	1800 <sub>25</sub>	1600 <sub>20</sub>	1500 <sub>15</sub>
300x45	40	5100	5100	3600 <sub>10</sub>	3500	2900 <sub>5</sub>	2800 <sub>15</sub>	2400 <sub>20</sub>	2000 <sub>15</sub>	2000 <sub>30</sub>	1700 <sub>35</sub>
	90	4400	4400	3600 <sub>15</sub>	3500 <sub>10</sub>	2800 <sub>15</sub>	2800 <sub>25</sub>	2400 <sub>30</sub>	2000 <sub>20</sub>	2200 <sub>40</sub>	1700 <sub>45</sub>
320x45	40	5500	5400	3900 <sub>10</sub>	3700 <sub>5</sub>	3100 <sub>10</sub>	3000 <sub>20</sub>	2600 <sub>20</sub>	2600 <sub>35</sub>	2300 <sub>40</sub>	1800 <sub>30</sub>
	90	4700	4600	3800 <sub>15</sub>	3700 <sub>10</sub>	3100 <sub>15</sub>	3000 <sub>30</sub>	2600 <sub>30</sub>	2600 <sub>45</sub>	2300 <sub>55</sub>	1800 <sub>40</sub>
360x45	40	6000	6000	4300 <sub>10</sub>	4300 <sub>15</sub>	3600 <sub>30</sub>	3400 <sub>20</sub>	3000 <sub>20</sub>	2900 <sub>45</sub>	2600 <sub>35</sub>	2100 <sub>25</sub>
	90	5100	5100	4300 <sub>20</sub>	4300 <sub>25</sub>	3500 <sub>30</sub>	3400 <sub>25</sub>	3000 <sub>30</sub>	2900 <sub>45</sub>	2600 <sub>50</sub>	2100 <sub>35</sub>
400x45	40	6500	6500	4800 <sub>10</sub>	4900 <sub>20</sub>	3900 <sub>30</sub>	3800 <sub>20</sub>	3400 <sub>45</sub>	3300 <sub>40</sub>	2900 <sub>30</sub>	2900 <sub>50</sub>
	90	5500	5500	4600 <sub>15</sub>	4600 <sub>20</sub>	3900 <sub>40</sub>	3800 <sub>30</sub>	3400 <sub>55</sub>	3200 <sub>55</sub>	2900 <sub>40</sub>	2900 <sub>65</sub>
120x70	40	2300	2300	1600	1200	1100	NS	NS	NS	NS	NS
	90	2200	2300	1600	1200	1100	NS	NS	NS	NS	NS
160x70	40	3100	3100	2200	2100	1700	1500	1500	1100	1100	NS
	90	3000	3000	2200	2100	1700	1500	1400	1100	1100	NS
200x70	40	4000	3900	2700	2700	2200	2200	1900	1700	1700	1400
	90	3500	3500	2700	2700	2200	2200	1900 <sub>5</sub>	1700	1700	1400
240x70	40	4800	4800	3400	3300	2700	2700	2300	2300	2100 <sub>5</sub>	1800 <sub>5</sub>
	90	4100	4000	3400	3200	2700	2700 <sub>5</sub>	2300 <sub>10</sub>	2300 <sub>5</sub>	2000 <sub>15</sub>	1800 <sub>10</sub>
280x70	40	5400	5400	4000	3900	3200	3100	2700	2700 <sub>10</sub>	2400 <sub>10</sub>	2400 <sub>20</sub>
	90	4500	4500	3800	3800	3200 <sub>10</sub>	3100 <sub>5</sub>	2700 <sub>5</sub>	2700 <sub>15</sub>	2400 <sub>20</sub>	2400 <sub>30</sub>
300x70	40	5700	5700	4200	4200	3500	3300	2900 <sub>5</sub>	2900 <sub>15</sub>	2600 <sub>10</sub>	2600 <sub>20</sub>
	90	4800	4800	4000	4000	3500 <sub>5</sub>	3300 <sub>5</sub>	2900 <sub>10</sub>	2900 <sub>25</sub>	2500 <sub>15</sub>	2600 <sub>30</sub>
320x70	40	5900	5900	4500	4500	3700 <sub>5</sub>	3600	3200 <sub>15</sub>	3100 <sub>15</sub>	2800 <sub>10</sub>	2800 <sub>20</sub>
	90	5000	5000	4200	4200	3700 <sub>15</sub>	3500 <sub>5</sub>	3100 <sub>25</sub>	3000 <sub>20</sub>	2700 <sub>15</sub>	2700 <sub>30</sub>
360x70	40	6400	6400	5100	5100 <sub>5</sub>	4200 <sub>10</sub>	4100 <sub>5</sub>	3600 <sub>20</sub>	3500 <sub>10</sub>	3200 <sub>30</sub>	3100 <sub>25</sub>
	90	5500	5500	4600	4600	4100 <sub>15</sub>	4100 <sub>10</sub>	3600 <sub>30</sub>	3400 <sub>20</sub>	3100 <sub>20</sub>	3000 <sub>35</sub>
400x70	40	6900	6900	5700 <sub>5</sub>	5600 <sub>5</sub>	4600 <sub>10</sub>	4700 <sub>10</sub>	4000 <sub>20</sub>	3900 <sub>15</sub>	3600 <sub>35</sub>	3500 <sub>25</sub>
	90	5900	5900	5000	5000 <sub>10</sub>	4500 <sub>15</sub>	4500 <sub>20</sub>	4000 <sub>30</sub>	3900 <sub>20</sub>	3500 <sub>35</sub>	3400 <sub>35</sub>
440x70	40	7400	7400	6300 <sub>5</sub>	6200 <sub>5</sub>	5100 <sub>10</sub>	5100 <sub>20</sub>	4400 <sub>25</sub>	4400 <sub>30</sub>	4000 <sub>35</sub>	3900 <sub>25</sub>
	90	6300	6300	5400 <sub>10</sub>	5400 <sub>10</sub>	4800 <sub>15</sub>	4800 <sub>30</sub>	4300 <sub>35</sub>	4300 <sub>45</sub>	3900 <sub>45</sub>	3800 <sub>30</sub>

## Single span lintels in single/upper storey walls AS 4055 classification C1, C2 and C3 (Cont'd)

Roof load width (mm)		1500		3000		4500		6000		7500	
Rafter/truss spacing (mm)		900	1200	900	1200	900	1200	900	1200	900	1200
Size DxB (mm)	Roof mass (kg/m <sup>2</sup> )	Maximum recommended lintel span (mm)									
200x90	40	4500	4500	3200	3100	2500	2500	2200	2100	2000	1800
	90	3800	3700	3200	3100	2500	2500	2100	2100	1900 <sub>5</sub>	1700
240x90	40	5100	5100	3900	3700	3100	3000	2600	2700	2300	2300
	90	4300	4300	3600	3600	3100	3000	2600	2600 <sub>5</sub>	2300 <sub>5</sub>	2300 <sub>5</sub>
280x90	40	5700	5700	4500	4500	3700	3500	3200 <sub>5</sub>	3100	2800	2800 <sub>10</sub>
	90	4800	4800	4100	4100	3600 <sub>5</sub>	3500	3100	3000 <sub>10</sub>	2700 <sub>5</sub>	2700 <sub>15</sub>
300x90	40	5900	6000	4800	4800	3900	3800	3400	3300	3000 <sub>5</sub>	2900 <sub>15</sub>
	90	5100	5100	4300	4300	3900 <sub>5</sub>	3800	3400 <sub>10</sub>	3200 <sub>5</sub>	2900 <sub>5</sub>	2900 <sub>20</sub>
320x90	40	6200	6200	5200	5200	4200	4100 <sub>5</sub>	3700 <sub>10</sub>	3500	3300 <sub>15</sub>	3100 <sub>10</sub>
	90	5300	5300	4500	4500	4000 <sub>5</sub>	4000 <sub>10</sub>	3600 <sub>5</sub>	3500 <sub>10</sub>	3200 <sub>25</sub>	3100 <sub>20</sub>
360x90	40	6800	6800	5800	5800	4700	4800 <sub>10</sub>	4100 <sub>10</sub>	4000 <sub>5</sub>	3700 <sub>20</sub>	3500 <sub>10</sub>
	90	5800	5800	4900	4900	4400 <sub>5</sub>	4400 <sub>10</sub>	4000 <sub>15</sub>	4000 <sub>10</sub>	3600 <sub>20</sub>	3500 <sub>15</sub>
400x90	40	7300	7300	6300	6200	5300 <sub>10</sub>	5300 <sub>10</sub>	4600 <sub>10</sub>	4600 <sub>15</sub>	4100 <sub>20</sub>	4000 <sub>15</sub>
	90	6200	6200	5300	5300	4800 <sub>5</sub>	4800 <sub>15</sub>	4400 <sub>20</sub>	4400 <sub>20</sub>	4000 <sub>30</sub>	3900 <sub>20</sub>
440x90	40	7800	7800	6700	6700 <sub>5</sub>	5800 <sub>10</sub>	5800 <sub>10</sub>	5100 <sub>10</sub>	5000 <sub>25</sub>	4500 <sub>25</sub>	4500 <sub>30</sub>
	90	6700	6700	5700	5700	5100 <sub>15</sub>	5100 <sub>15</sub>	4800 <sub>15</sub>	4700 <sub>30</sub>	4400 <sub>35</sub>	4400 <sub>40</sub>
200x120	40	4700	4700	3700	3600	3000	2900	2500	2500	2200	2200
	90	4000	4000	3400	3400	2900	2900	2500	2500	2200	2200
240x120	40	5400	5400	4400	4400	3700	3500	3100	3000	2700	2700
	90	4600	4600	3900	3900	3500	3500	3100	3000	2700	2700 <sub>5</sub>
280x120	40	6000	6000	5100	5200	4200	4200	3700	3600	3300	3200
	90	5100	5100	4300	4300	3900	3900	3600 <sub>5</sub>	3500	3200 <sub>5</sub>	3100 <sub>5</sub>
300x120	40	6300	6300	5400	5400	4500	4600	4000	3800	3600 <sub>5</sub>	3400
	90	5400	5400	4600	4600	4100	4100	3800 <sub>5</sub>	3800	3500 <sub>5</sub>	3300 <sub>5</sub>
320x120	40	6600	6600	5700	5700	4900	4900	4200	4200 <sub>5</sub>	3800 <sub>5</sub>	3600
	90	5600	5600	4800	4800	4300	4300	4000 <sub>5</sub>	4000	3700 <sub>15</sub>	3600 <sub>5</sub>
360x120	40	7100	7100	6200	6100	5500	5500	4800	4800 <sub>10</sub>	4200 <sub>10</sub>	4200 <sub>15</sub>
	90	6100	6100	5200	5200	4700	4700	4400 <sub>5</sub>	4400 <sub>10</sub>	4100 <sub>20</sub>	4100 <sub>10</sub>
400x120	40	7700	7700	6600	6700	6000	6000	5300 <sub>10</sub>	5300 <sub>10</sub>	4700 <sub>5</sub>	4800 <sub>20</sub>
	90	6600	6600	5600	5700	5100 <sub>5</sub>	5100 <sub>5</sub>	4700 <sub>5</sub>	4700 <sub>15</sub>	4500 <sub>15</sub>	4500 <sub>20</sub>
440x120	40	8200	8100	7100	7100	6400	6400	5900 <sub>10</sub>	5800 <sub>10</sub>	5300 <sub>20</sub>	5200 <sub>20</sub>
	90	7100	7100	6100	6100	5500 <sub>5</sub>	5500 <sub>10</sub>	5100 <sub>5</sub>	5100 <sub>15</sub>	4800 <sub>15</sub>	4800 <sub>30</sub>
240x140	40	5600	5600	4800	4800	3900	3800	3400	3300	3000	2900
	90	4700	4700	4000	4000	3600	3600	3300	3200	2900	2900
280x140	40	6200	6200	5300	5300	4600	4600	4000	3900	3600	3400
	90	5300	5300	4500	4500	4100	4100	3800	3700	3500	3400
300x140	40	6500	6500	5600	5600	4900	4900	4300	4200	3800	3700
	90	5600	5600	4700	4700	4300	4300	4000	4000	3700 <sub>5</sub>	3600
320x140	40	6800	6800	5800	5800	5300	5300	4600	4600	4100 <sub>5</sub>	4000
	90	5800	5800	5000	5000	4500	4500	4200	4200 <sub>5</sub>	3900 <sub>5</sub>	3900 <sub>5</sub>
360x140	40	7300	7300	6300	6400	5800	5700	5200	5100 <sub>5</sub>	4600	4600 <sub>5</sub>
	90	6300	6300	5400	5400	4900	4900	4500	4500	4300 <sub>10</sub>	4300 <sub>15</sub>
400x140	40	7900	7800	6800	6900	6200	6200	5800 <sub>5</sub>	5700 <sub>5</sub>	5200 <sub>10</sub>	5100 <sub>15</sub>
	90	6800	6800	5800	5900	5300	5300	4900	4900 <sub>10</sub>	4600 <sub>10</sub>	4600 <sub>10</sub>
440x140	40	8400	8300	7300	7300	6600	6700 <sub>5</sub>	6200 <sub>10</sub>	6200 <sub>5</sub>	5700 <sub>15</sub>	5600 <sub>15</sub>
	90	7300	7300	6300	6300	5700	5700	5300 <sub>10</sub>	5300 <sub>10</sub>	5000 <sub>10</sub>	5000 <sub>20</sub>

### NOTES:

1. D = member depth, B = member breadth, NS = not suitable.
2. Minimum bearing length = 35 mm at end supports. Subscript values indicate the minimum additional bearing length where required to be greater than 35 mm
3. Restraint value for slenderness calculations is 600 mm
4. Not all sizes of SmartLam GLT15S in this table are stocked in each state. Please check with your supplier before ordering
5. Table does not list all available SmartLam GLT15S sizes. See page 11 for full list of sizes

# Single span lintels in lower storey walls AS 4055 classification N1, N2, N3 & C1

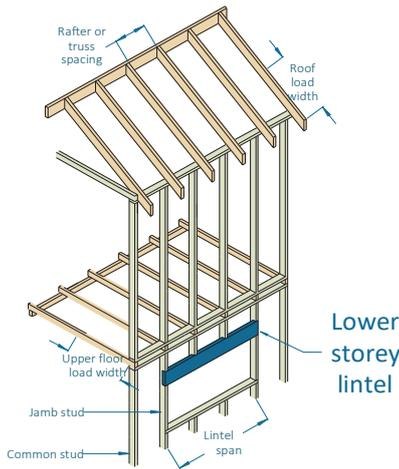

### EXAMPLE:

wind speed = N3  
 sheet roof - 40 kg/m<sup>2</sup>  
 rafter/truss spacing = 600 mm  
 lintel span = 3500 mm  
 roof load width = 3900 mm  
 floor load width = 2400 mm  
 Enter span table at 4500 roof load width column, floor load width 2400 mm, and read down to a span equal to or greater than 3500 mm in 40 kg/m<sup>2</sup> row

### ADOPT:

SmartLam GLT15S - 360 x 45 (requires 10 additional bearing)

Roof load width (mm)		1500			3000			4500			6000		
Floor load width (mm)		1200	2400	3600	1200	2400	3600	1200	2400	3600	1200	2400	3600
Member size DxB (mm)	Roof mass (kg/m <sup>2</sup> )	Maximum recommended Lintel span (mm)											
		Single span											
120x45	40	1700	1500	1400	1600	1400	1300	1400	1300	1200	1400	1300	1200
	90	1500	1400	1300	1400	1300	1200	1300	1200	1100	1200	1100	1100
160x45	40	2200	2000	1800	2100	1900	1700	1900	1800	1700	1800	1700	1600
	90	2100	1900	1700	1900	1700	1600	1700	1600	1500	1600	1500	1400
200x45	40	2800	2500	2300	2600	2400	2200	2400	2300	2100	2300	2100	2000
	90	2600	2400	2200	2300	2200	2000	2100	2000	1900	2000	1900	1800 <sub>5</sub>
240x45	40	3300	3000	2800 <sub>5</sub>	3100	2900	2600 <sub>5</sub>	2900	2700	2500 <sub>5</sub>	2800	2600	2400 <sub>5</sub>
	90	3100	2900	2600 <sub>5</sub>	2800	2600	2500 <sub>5</sub>	2600	2400	2300 <sub>10</sub>	2400 <sub>5</sub>	2300 <sub>5</sub>	2200 <sub>10</sub>
280x45	40	3700	3400	3200 <sub>10</sub>	3500	3200	3100 <sub>10</sub>	3300	3100	3000 <sub>10</sub>	3100	3000 <sub>5</sub>	2800 <sub>15</sub>
	90	3500	3200	3100 <sub>10</sub>	3200	3000 <sub>5</sub>	2900 <sub>10</sub>	3000 <sub>5</sub>	2800 <sub>10</sub>	2700 <sub>15</sub>	2800 <sub>10</sub>	2700 <sub>15</sub>	2500 <sub>20</sub>
300x45	40	3900	3600	3300 <sub>10</sub>	3700	3400	3200 <sub>10</sub>	3500	3300 <sub>5</sub>	3100 <sub>15</sub>	3300	3200 <sub>5</sub>	3000 <sub>15</sub>
	90	3700	3400	3200 <sub>10</sub>	3400	3200 <sub>5</sub>	3000 <sub>15</sub>	3100 <sub>5</sub>	3000 <sub>10</sub>	2900 <sub>20</sub>	3000 <sub>15</sub>	2800 <sub>15</sub>	2700 <sub>20</sub>
320x45	40	4100	3700	3500 <sub>10</sub>	3800	3600 <sub>5</sub>	3400 <sub>15</sub>	3700	3400 <sub>5</sub>	3300 <sub>15</sub>	3500	3300 <sub>10</sub>	3200 <sub>15</sub>
	90	3800	3600 <sub>5</sub>	3400 <sub>15</sub>	3500	3300 <sub>10</sub>	3200 <sub>15</sub>	3300 <sub>10</sub>	3200 <sub>10</sub>	3000 <sub>20</sub>	3100 <sub>15</sub>	3000 <sub>20</sub>	2900 <sub>25</sub>
360x45	40	4400	4100 <sub>5</sub>	3800 <sub>15</sub>	4200	3900 <sub>5</sub>	3700 <sub>20</sub>	4000	3800 <sub>10</sub>	3600 <sub>20</sub>	3800 <sub>5</sub>	3600 <sub>15</sub>	3500 <sub>20</sub>
	90	4200	3900 <sub>5</sub>	3700 <sub>20</sub>	3900 <sub>5</sub>	3700 <sub>10</sub>	3500 <sub>20</sub>	3600 <sub>10</sub>	3500 <sub>15</sub>	3300 <sub>25</sub>	3400 <sub>20</sub>	3300 <sub>25</sub>	3200 <sub>30</sub>
400x45	40	4800	4400 <sub>10</sub>	4100 <sub>20</sub>	4500	4200 <sub>10</sub>	4000 <sub>20</sub>	4300 <sub>5</sub>	4100 <sub>15</sub>	3900 <sub>25</sub>	4100 <sub>10</sub>	3900 <sub>15</sub>	3800 <sub>25</sub>
	90	4500	4200 <sub>10</sub>	4000 <sub>20</sub>	4200 <sub>5</sub>	4000 <sub>15</sub>	3800 <sub>25</sub>	3900 <sub>15</sub>	3700 <sub>20</sub>	3600 <sub>30</sub>	3700 <sub>25</sub>	3600 <sub>30</sub>	3500 <sub>35</sub>
120x70	40	1900	1700	1500	1700	1600	1500	1600	1500	1400	1500	1400	1300
	90	1700	1600	1500	1500	1400	1300	1400	1300	1300	1300	1200	1200
160x70	40	2500	2200	2000	2300	2100	1900	2200	2000	1900	2000	1900	1800
	90	2300	2100	1900	2100	1900	1800	1900	1800	1700	1700	1700	1600
200x70	40	3100	2800	2600	2900	2600	2400	2700	2500	2300	2600	2400	2200
	90	2900	2600	2400	2600	2400	2300	2400	2200	2100	2200	2100	2000
240x70	40	3500	3300	3000	3300	3100	2900	3200	3000	2800	3000	2900	2700
	90	3300	3100	2900	3100	2900	2700	2800	2700	2600	2600	2500	2400
280x70	40	4000	3700	3400	3800	3500	3300	3600	3400	3200	3400	3200	3100
	90	3800	3500	3300	3500	3300	3100	3200	3100	3000	3100	3000	2800 <sub>5</sub>
300x70	40	4200	3800	3600	4000	3700	3500	3800	3600	3400	3600	3400	3300
	90	4000	3700	3500	3600	3500	3300	3400	3300	3100 <sub>5</sub>	3200	3100	3000 <sub>5</sub>
320x70	40	4400	4000	3800	4200	3900	3700	4000	3700	3500	3800	3600	3400 <sub>5</sub>
	90	4200	3900	3700	3800	3600	3500	3600	3400	3300 <sub>5</sub>	3400	3300 <sub>5</sub>	3200 <sub>5</sub>
360x70	40	4800	4400	4100	4500	4200	4000	4300	4100	3900 <sub>5</sub>	4100	3900	3800 <sub>5</sub>
	90	4500	4200	4000	4200	4000	3800 <sub>5</sub>	3900	3700 <sub>5</sub>	3600 <sub>10</sub>	3700 <sub>5</sub>	3600 <sub>5</sub>	3500 <sub>10</sub>
400x70	40	5200	4800	4500 <sub>5</sub>	4900	4600	4300 <sub>5</sub>	4700	4400	4200 <sub>5</sub>	4500	4300	4100 <sub>10</sub>
	90	4900	4600	4300 <sub>5</sub>	4500	4300	4100 <sub>10</sub>	4200	4100 <sub>5</sub>	3900 <sub>10</sub>	4000 <sub>10</sub>	3900 <sub>10</sub>	3800 <sub>15</sub>
440x70	40	5600	5100	4800 <sub>5</sub>	5300	4900	4700 <sub>10</sub>	5000	4700	4500 <sub>10</sub>	4800	4600 <sub>5</sub>	4400 <sub>10</sub>
	90	5300	4900	4600 <sub>10</sub>	4800	4600 <sub>5</sub>	4400 <sub>10</sub>	4500 <sub>5</sub>	4400 <sub>10</sub>	4200 <sub>15</sub>	4300 <sub>10</sub>	4200 <sub>15</sub>	4000 <sub>20</sub>
200x90	40	3300	3000	2800	3100	2900	2700	3000	2700	2600	2800	2600	2400
	90	3100	2900	2700	2800	2600	2500	2600	2400	2300	2400	2300	2200
240x90	40	3800	3500	3200	3600	3300	3100	3400	3200	3000	3200	3100	2900
	90	3600	3300	3100	3300	3100	3000	3100	2900	2800	2900	2800	2600
280x90	40	4200	3900	3600	4000	3700	3500	3800	3600	3400	3600	3500	3300
	90	4000	3700	3500	3700	3500	3300	3400	3300	3200	3300	3100	3100
300x90	40	4400	4100	3800	4200	3900	3700	4000	3800	3600	3800	3600	3500
	90	4200	3900	3700	3900	3700	3500	3600	3500	3400	3400	3300	3200

## Single span lintels in lower storey walls AS 4055 classification N1, N2, N3 & C1

Roof load width (mm)		1500			3000			4500			6000		
Floor load width (mm)		1200	2400	3600	1200	2400	3600	1200	2400	3600	1200	2400	3600
Member size DxB (mm)	Roof mass (kg/m <sup>2</sup> )	Maximum recommended Lintel span (mm)											
		Single span											
320x90	40	4700	4300	4000	4400	4100	3900	4200	4000	3800	4000	3800	3700
	90	4400	4100	3900	4100	3900	3700	3800	3700	3500	3600	3500	3400
360x90	40	5100	4700	4400	4800	4500	4300	4600	4300	4100	4400	4200	4000
	90	4800	4500	4300	4400	4200	4000	4200	4000	3800	3900	3800	3700 <sub>5</sub>
400x90	40	5500	5100	4800	5200	4900	4600	5000	4700	4500	4700	4500	4300 <sub>5</sub>
	90	5200	4900	4600	4800	4600	4400	4500	4300	4200 <sub>5</sub>	4300	4100 <sub>5</sub>	4000 <sub>5</sub>
440x90	40	5900	5400	5100	5600	5200	4900	5300	5000	4800 <sub>5</sub>	5100	4900	4700 <sub>5</sub>
	90	5600	5200	4900	5200	4900	4700 <sub>5</sub>	4800	4600	4500 <sub>5</sub>	4600 <sub>5</sub>	4400 <sub>5</sub>	4300 <sub>10</sub>
200x120	40	3500	3200	3000	3300	3100	2900	3200	3000	2800	3000	2900	2700
	90	3300	3100	2900	3100	2900	2700	2800	2700	2600	2600	2500	2400
240x120	40	4000	3700	3500	3800	3600	3400	3600	3400	3300	3500	3300	3200
	90	3800	3600	3400	3500	3300	3200	3300	3200	3000	3100	3000	2900
280x120	40	4500	4200	3900	4300	4000	3800	4100	3800	3700	3900	3700	3600
	90	4300	4000	3800	3900	3700	3600	3700	3500	3400	3500	3400	3300
300x120	40	4800	4400	4100	4500	4200	4000	4300	4100	3900	4100	3900	3700
	90	4500	4200	4000	4100	3900	3800	3900	3700	3600	3700	3600	3500
320x120	40	5000	4600	4300	4700	4400	4200	4500	4300	4100	4300	4100	3900
	90	4700	4400	4200	4400	4100	4000	4100	3900	3800	3900	3700	3600
360x120	40	5400	5000	4700	5200	4800	4600	4900	4600	4400	4700	4500	4300
	90	5200	4800	4600	4800	4500	4300	4500	4300	4100	4200	4100	4000
400x120	40	5900	5400	5100	5600	5200	4900	5300	5000	4800	5100	4800	4600
	90	5600	5200	4900	5100	4900	4700	4800	4600	4500	4600	4400	4300
440x120	40	6300	5800	5500	6000	5600	5300	5700	5400	5100	5500	5200	5000
	90	6000	5600	5300	5500	5300	5000	5200	5000	4800	4900	4700	4600
240x140	40	4200	3900	3600	4000	3700	3500	3800	3600	3400	3600	3400	3300
	90	4000	3700	3500	3600	3500	3300	3400	3300	3200	3200	3100	3000
280x140	40	4700	4300	4000	4400	4200	3900	4200	4000	3800	4000	3900	3700
	90	4400	4100	3900	4100	3900	3700	3800	3700	3500	3600	3500	3400
300x140	40	4900	4500	4300	4700	4400	4100	4500	4200	4000	4300	4100	3900
	90	4700	4400	4100	4300	4100	3900	4000	3900	3700	3800	3700	3600
320x140	40	5200	4800	4500	4900	4600	4300	4700	4400	4200	4500	4300	4100
	90	4900	4600	4300	4500	4300	4100	4200	4100	3900	4000	3900	3800
360x140	40	5600	5200	4900	5400	5000	4700	5100	4800	4600	4900	4600	4500
	90	5300	5000	4700	4900	4700	4500	4600	4400	4300	4400	4200	4100
400x140	40	6100	5600	5300	5800	5400	5100	5500	5200	5000	5300	5000	4800
	90	5800	5400	5100	5300	5100	4900	5000	4800	4600	4700	4600	4500
440x140	40	6500	6000	5700	6200	5800	5500	5900	5600	5300	5700	5400	5200
	90	6200	5800	5500	5700	5400	5200	5400	5200	5000	5100	4900	4800

### NOTES:

- D = member depth, B = member breadth, NS = not suitable.
- Total Upper floor mass of 40 kg/m<sup>2</sup>, floor live load of 1.5 kPa, floor point load of 1.8 kN
- Minimum bearing length = 35 mm at end supports. Subscript values indicate the minimum additional bearing length where required to be greater than 35 mm.
- Restraint value for slenderness calculations is 600 mm.
- Not all sizes of SmartLam GLT15S in this table are stocked in each state. Please check with your supplier before ordering
- Table does not list all available SmartLam GLT15S sizes. See page 11 for full list of sizes

# Single/continuous span roof rafter - AS 4055 classification N1, N2 and N3 - with ceiling attached

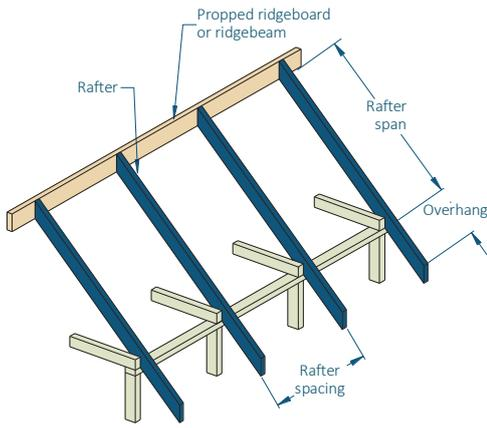

Maximum Birdsmouth = 30% of rafter depth

## EXAMPLE:

wind speed = N3  
sheet roof - 40 kg/m<sup>2</sup>  
rafter/truss spacing = 600 mm  
rafter span = 5000 mm

Enter span table at rafter spacing of 600 mm, and read down to a span equal to or greater than 5000 mm in 40 kg/m<sup>2</sup> row

## ADOPT:

SmartLam GLT15S - 200 x 45

Rafter spacing (mm)		450	600	900	1200	450	600	900	1200
Member size DxB (mm)	Roof mass (kg/m <sup>2</sup> )	Maximum recommended Rafter span (mm)							
		Single span				Continuous span			
120x45	30	3900	3800	3400	3200	4900	4900	4700	4300
	40	3900	3600	3200	2900	4900	4900	4300	3900
	75	3200	2900	2600	2400	4400	4000	3500	3200
	90	3000	2800	2400	2200	4100	3800	3300	3000
160x45	30	5500	5100	4500	4200	6600	6600	6100	5700
	40	5100	4700	4200	3800	6600	6300	5700	5200
	75	4300	3900	3400	3100	5800	5300	4700	4300
	90	4000	3700	3200	3000	5500	5000	4400	4000
200x45	30	6500	6200	5600	5200	8200	7800	7200	6700
	40	6200	5800	5200	4800	7800	7300	6700	6300
	75	5300	4900	4300	3900	6900	6400	5800	5300
	90	5000	4600	4100	3700	6600	6200	5500	5000
240x45	30	7400	7000	6500	6100	9200	8800	8100	7700
	40	7000	6600	6100	5700	8800	8300	7700	7200
	75	6200	5800	5100	4700	7800	7300	6700	6300
	90	6000	5500	4900	4400	7500	7000	6400	6000
280x45	30	8200	7800	7200	6800	10200	9800	9100	8600
	40	7700	7400	6800	6400	9700	9300	8600	8100
	75	6900	6500	6000	5500	8700	8200	7500	7000
	90	6600	6300	5600	5200	8300	7900	7200	6700
300x45	30	8500	8100	7600	7100	10700	10300	9500	9000
	40	8100	7700	7100	6700	10200	9800	9000	8500
	75	7300	6800	6300	5800	9100	8600	7900	7400
	90	7000	6600	6000	5500	8800	8300	7500	7100
320x45	30	8900	8500	7900	7500	11100	10700	9900	9400
	40	8500	8100	7500	7100	10600	10200	9400	8900
	75	7600	7100	6600	6100	9500	9000	8200	7700
	90	7300	6900	6300	5900	9200	8600	7900	7400
360x45	30	9500	9200	8600	8100	12000	11600	10800	10200
	40	9100	8800	8100	7700	11600	11000	10200	9600
	75	8200	7800	7100	6700	10300	9800	9000	8400
	90	7900	7500	6800	6400	9900	9400	8600	8100
400x45	30	10200	9900	9200	8700	12000	12000	11600	11000
	40	9800	9400	8700	8300	12000	11800	11000	10400
	75	8900	8400	7700	7200	11100	10500	9700	9100
	90	8500	8100	7400	6900	10700	10100	9300	8700
120x70	30	4500	4200	3800	3500	5500	5500	5100	4700
	40	4200	3900	3500	3200	5500	5300	4700	4300
	75	3500	3200	2900	2600	4800	4400	3900	3600
	90	3300	3100	2700	2500	4600	4200	3700	3400
160x70	30	5800	5500	4900	4600	7300	7000	6500	6100
	40	5500	5100	4600	4200	7000	6700	6100	5700
	75	4600	4300	3800	3500	6200	5800	5200	4700
	90	4400	4100	3600	3300	6000	5500	4900	4500
200x70	30	6800	6500	6000	5600	8500	8200	7600	7200
	40	6500	6200	5600	5200	8100	7800	7200	6800
	75	5700	5300	4700	4300	7300	6900	6300	5900
	90	5500	5000	4500	4100	7000	6600	6000	5600

## Single/continuous span roof rafter - AS 4055 classification N1, N2 and N3 - with ceiling attached (Cont'd)

Rafter spacing (mm)		450	600	900	1200	450	600	900	1200
Member size DxB (mm)	Roof mass (kg/m <sup>2</sup> )	Maximum recommended Rafter span (mm)							
		Single span				Continuous span			
280x70	30	8400	8100	7600	7200	10500	10200	9500	9100
	40	8100	7800	7200	6800	10100	9800	9100	8600
	75	7300	6900	6400	6000	9100	8700	8000	7500
	90	7000	6700	6100	5700	8800	8400	7700	7200
300x70	30	8800	8500	7900	7600	11000	10700	10000	9500
	40	8400	8100	7500	7200	10600	10200	9500	9000
	75	7700	7200	6700	6300	9600	9100	8400	7900
	90	7400	7000	6400	6000	9300	8800	8100	7600
320x70	30	9100	8800	8300	7900	11500	11100	10400	10000
	40	8800	8500	7900	7500	11100	10700	9900	9400
	75	8000	7600	7000	6600	10000	9600	8800	8300
	90	7700	7300	6700	6300	9700	9200	8500	8000
360x70	30	9800	9500	9000	8500	12000	11900	11300	10700
	40	9500	9100	8500	8100	11900	11500	10700	10200
	75	8700	8200	7600	7200	10800	10400	9500	9000
	90	8400	7900	7300	6900	10500	10000	9200	8700
400x70	30	10500	10200	9600	9200	12000	12000	12000	11600
	40	10100	9800	9200	8700	12000	12000	11600	11000
	75	9300	8800	8200	7700	11700	11100	10300	9700
	90	9000	8500	7900	7400	11300	10700	9900	9300
440x70	30	11100	10800	10200	9800	12000	12000	12000	12000
	40	10700	10400	9800	9300	12000	12000	12000	11700
	75	9900	9400	8700	8300	12000	11800	11000	10400
	90	9600	9100	8400	7900	12000	11500	10600	10000
200x90	30	7000	6800	6300	6000	8800	8500	7900	7600
	40	6700	6500	6000	5600	8500	8100	7500	7100
	75	6100	5700	5100	4700	7600	7200	6600	6200
	90	5800	5400	4800	4400	7400	7000	6400	6000
240x90	30	7900	7600	7100	6800	9900	9600	9000	8500
	40	7600	7300	6800	6400	9500	9200	8500	8100
	75	6900	6500	6000	5600	8600	8200	7600	7100
	90	6600	6300	5700	5300	8300	7900	7300	6800
280x90	30	8700	8400	7900	7600	10900	10600	9900	9500
	40	8300	8100	7500	7200	10500	10100	9500	9000
	75	7600	7300	6700	6300	9600	9100	8400	7900
	90	7400	7000	6500	6100	9300	8800	8100	7600
300x90	30	9000	8800	8300	7900	11400	11000	10400	10000
	40	8700	8400	7900	7500	11000	10600	9900	9500
	75	8000	7600	7000	6600	10000	9600	8800	8300
	90	7700	7400	6800	6400	9700	9300	8500	8000
320x90	30	9400	9100	8600	8300	11800	11500	10800	10400
	40	9100	8800	8200	7900	11500	11100	10400	9900
	75	8300	8000	7300	6900	10400	10000	9200	8700
	90	8100	7700	7100	6700	10100	9700	8900	8400
360x90	30	10100	9800	9300	8900	12000	12000	11700	11200
	40	9800	9500	8900	8500	12000	11900	11200	10700
	75	9000	8600	8000	7500	11300	10800	10000	9500
	90	8700	8300	7700	7300	11000	10500	9700	9100
400x90	30	10800	10500	9900	9600	12000	12000	12000	12000
	40	10400	10100	9500	9100	12000	12000	12000	11500
	75	9700	9200	8600	8100	12000	11600	10800	10200
	90	9400	8900	8300	7800	11800	11200	10400	9800
440x90	30	11400	11100	10500	10200	12000	12000	12000	12000
	40	11000	10700	10100	9700	12000	12000	12000	12000
	75	10300	9800	9200	8700	12000	12000	11600	10900
	90	10000	9600	8800	8400	12000	12000	11100	10500

## Single/continuous span roof rafter AS 4055 classification C1, C2 and C3 - with ceiling attached

Rafter spacing (mm)		450	600	900	1200	450	600	900	1200
Size DxB (mm)	Roof mass (kg/m <sup>2</sup> )	Maximum recommended rafter span (mm)							
		Single Span				Continuous span			
120x45	30	3900	3500	2700	2300	4100	3500	2700	2300
	40	3900	3500	2800	2300	4200	3500	2800	2300
	75	3200	2900	2600	2400	4200	3600	2900	2400
	90	3000	2800	2400	2200	4100	3600	2800	2300
160x45	30	5400	4700	3800	3100	5500	4700	3800	3100
	40	5100	4700	3800	3200	5600	4800	3800	3200
	75	4300	3900	3400	3100	5700	4900	3900	3300
	90	4000	3700	3200	3000	5500	4800	3800	3200
200x45	30	6400	5900	4800	4000	6900	6000	4800	4000
	40	6200	5800	4800	4000	7000	6000	4800	4000
	75	5300	4900	4300	3900	6900	6100	4900	4200
	90	5000	4600	4100	3700	6600	6000	4800	4100
240x45	30	7400	6800	5700	4900	8400	7200	5800	4900
	40	7000	6600	5800	4900	8500	7300	5800	4900
	75	6200	5800	5100	4700	7800	7300	5900	5100
	90	6000	5500	4900	4400	7500	7000	5800	5000
280x45	30	8200	7700	6700	5700	9800	8400	6800	5700
	40	7800	7400	6800	5800	9700	8500	6800	5800
	75	6900	6500	6000	5500	8700	8200	7000	5900 <sub>10</sub>
	90	6700	6300	5600	5200	8300	7900	6800	5800 <sub>10</sub>
300x45	30	8500	8100	7300	6200	10500	9000	7300	6200
	40	8100	7700	7100	6200	10300	9100	7300	6200 <sub>5</sub>
	75	7200	6800	6300	5800	9100	8600	7500 <sub>5</sub>	6400 <sub>10</sub>
	90	7000	6600	6000	5500	8800	8300	7300 <sub>5</sub>	6200 <sub>15</sub>
320x45	30	8900	8500	7700	6600	11200	9700	7800	6600 <sub>5</sub>
	40	8500	8100	7500	6700	10700	9800	7800	6700 <sub>10</sub>
	75	7600	7100	6600	6100	9500	9000	8000 <sub>10</sub>	6800 <sub>15</sub>
	90	7300	6900	6300	5900	9200	8600	7800 <sub>10</sub>	6700 <sub>15</sub>
360x45	30	9500	9200	8400	7500	12000	10900	8800 <sub>5</sub>	7500 <sub>15</sub>
	40	9200	8700	8100	7500	11600	11000	8900 <sub>10</sub>	7600 <sub>15</sub>
	75	8200	7800	7100	6700	10300	9800	9000 <sub>15</sub>	7700 <sub>25</sub>
	90	7900	7500	6800	6400	9900	9400	8600 <sub>15</sub>	7500 <sub>25</sub>
400x45	30	10200	9900	9100	8300	12000	12000	9800 <sub>15</sub>	8300 <sub>20</sub>
	40	9800	9400	8700	8300	12000	11800	9900 <sub>15</sub>	8400 <sub>25</sub>
	75	8900	8400	7700	7200	11100	10500	9700 <sub>20</sub>	8600 <sub>35</sub>
	90	8500	8100	7400	6900	10700	10100	9300 <sub>20</sub>	8400 <sub>35</sub>
120x70	30	4500	4200	3300	2700	4900	4200	3300	2700
	40	4200	3900	3300	2800	4900	4200	3300	2800
	75	3500	3200	2900	2600	4800	4300	3400	2900
	90	3300	3100	2700	2500	4600	4200	3300	2800
160x70	30	5800	5500	4500	3800	6600	5600	4500	3800
	40	5500	5100	4500	3800	6600	5700	4500	3800
	75	4600	4300	3800	3500	6200	5700	4600	3900
	90	4400	4100	3600	3300	6000	5500	4500	3800
200x70	30	6800	6500	5600	4800	8300	7100	5600	4800
	40	6500	6200	5600	4800	8100	7100	5700	4800
	75	5700	5300	4700	4300	7300	6900	5800	4900
	90	5500	5000	4500	4100	7000	6600	5700	4800
240x70	30	7600	7300	6700	5800	9600	8500	6800	5800
	40	7300	7000	6500	5900	9200	8600	6900	5900
	75	6600	6200	5600	5200	8200	7800	7000	6000
	90	6300	6000	5300	4900	8000	7500	6800	5800
280x70	30	8400	8100	7500	6800	10600	10000	8000	6800
	40	8100	7800	7200	6800	10100	9800	8100	6900
	75	7300	6900	6400	6000	9100	8700	8000	7000
	90	7100	6700	6100	5700	8800	8400	7700	6900

## Single/continuous span roof rafter AS 4055 classification C1, C2 and C3 - with ceiling attached (Cont'd)

Rafter spacing (mm)		450	600	900	1200	450	600	900	1200
Size DxB (mm)	Roof mass (kg/m <sup>2</sup> )	Maximum recommended rafter span (mm)							
		Single Span				Continuous span			
300x70	30	8800	8500	7900	7300	11000	10700	8600	7300
	40	8500	8100	7500	7200	10600	10200	8700	7400
	75	7600	7300	6700	6300	9600	9100	8400	7500
	90	7400	7000	6400	6000	9300	8800	8100	7400
320x70	30	9100	8800	8300	7700	11500	11100	9200	7900
	40	8800	8500	7900	7500	11100	10700	9300	7900
	75	8000	7600	7000	6600	10000	9600	8800	8000
	90	7700	7300	6700	6300	9700	9200	8500	7900
360x70	30	9800	9500	9000	8500	12000	11900	10400	8900
	40	9500	9100	8500	8100	11900	11500	10500	9000
	75	8700	8200	7600	7200	10800	10400	9500	9000 <sub>5</sub>
	90	8400	7900	7300	6900	10500	10000	9200	8700 <sub>5</sub>
400x70	30	10500	10200	9600	9200	12000	12000	11600	9900 <sub>5</sub>
	40	10100	9800	9200	8700	12000	12000	11600	10000 <sub>10</sub>
	75	9300	8800	8200	7700	11700	11100	10300	9700 <sub>10</sub>
	90	9000	8500	7900	7400	11300	10700	9900	9300 <sub>10</sub>
440x70	30	11100	10800	10200	9800	12000	12000	12000	11000 <sub>10</sub>
	40	10800	10400	9800	9300	12000	12000	12000	11100 <sub>15</sub>
	75	9800	9400	8700	8300	12000	11800	11000 <sub>5</sub>	10400 <sub>15</sub>
	90	9600	9100	8400	7900	12000	11500	10600 <sub>5</sub>	10000 <sub>15</sub>
200x90	30	7000	6800	6200	5500	8800	8100	6500	5500
	40	6800	6400	6000	5500	8500	8100	6500	5500
	75	6100	5700	5100	4700	7600	7200	6600	5600
	90	5800	5400	4800	4400	7400	7000	6400	5500
240x90	30	7900	7600	7100	6600	9900	9600	7800	6600
	40	7600	7300	6800	6400	9500	9200	7900	6700
	75	6900	6500	6000	5600	8600	8200	7600	6800
	90	6700	6300	5700	5300	8300	7900	7300	6600
280x90	30	8700	8400	7900	7500	10900	10600	9200	7800
	40	8400	8100	7500	7200	10500	10100	9300	7900
	75	7600	7300	6700	6300	9600	9100	8400	7900
	90	7400	7000	6500	6100	9300	8800	8100	7600
300x90	30	9000	8800	8300	7900	11400	11000	9800	8400
	40	8700	8400	7900	7500	11000	10600	9900	8500
	75	8000	7600	7000	6600	10000	9600	8800	8300
	90	7700	7400	6800	6400	9700	9300	8500	8000
320x90	30	9400	9100	8600	8300	11800	11500	10500	9000
	40	9100	8800	8200	7900	11500	11100	10400	9100
	75	8300	8000	7300	6900	10400	10000	9200	8700
	90	8100	7700	7100	6700	10100	9700	8900	8400
360x90	30	10100	9800	9300	8900	12000	12000	11700	10200
	40	9800	9500	8900	8500	12000	11900	11200	10300
	75	9000	8600	8000	7500	11300	10800	10000	9500
	90	8700	8300	7700	7300	11000	10500	9700	9100
400x90	30	10800	10500	9900	9600	12000	12000	12000	11300
	40	10400	10100	9500	9100	12000	12000	12000	11500
	75	9700	9200	8600	8100	12000	11600	10800	10200
	90	9400	8900	8300	7800	11800	11200	10400	9800
440x90	30	11400	11100	10500	10200	12000	12000	12000	12000
	40	11000	10700	10100	9700	12000	12000	12000	12000 <sub>5</sub>
	75	10300	9800	9200	8700	12000	12000	11600	10900 <sub>5</sub>
	90	10000	9600	8800	8400	12000	12000	11100	10500 <sub>5</sub>

### NOTES:

- D = member depth, B = member breadth, NS = not suitable.
- The above table was based on a batten spacing of 900 mm
- Maximum birds mouth depth = 30 % of rafter depth
- End bearing lengths = 45 mm at end supports and 45 mm at internal supports for continuous members. Subscript values Indicate the minimum additional bearing length where required to be greater than 45 mm at end supports and 45 mm at internal supports
- Construction loads shall not be applied to overhangs until a 190 x 19 (minimum) timber fascia or other fascia of equivalent stiffness is rigidly and permanently attached to the end of rafter overhangs
- Rafter spacing up to 1200 mm
- Not all sizes of SmartLam GLT15S in this table are stocked in each state. Please check with your supplier before ordering
- Table does not list all available SmartLam GLT15S sizes. See page 11 for full list of sizes

# Single/continuous span roof rafter- AS 4055 classification N1, N2 and N3 - without ceiling attached

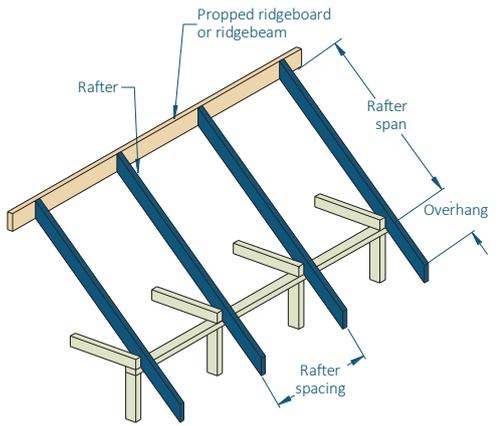

Maximum Birdsmouth = 30% of rafter depth

### EXAMPLE:

wind speed = N3  
sheet roof - 40 kg/m<sup>2</sup>  
rafter/truss spacing = 600 mm  
rafter span = 5000 mm

Enter span table at rafter spacing of 600 mm, and read down to a span equal to or greater than 5000 mm in 40 kg/m<sup>2</sup> row

### ADOPT:

SmartLam GLT15S - 200 x 45

Rafter spacing (mm)		450	600	900	1200	450	600	900	1200
Member size DxB (mm)	Roof mass (kg/m <sup>2</sup> )	Maximum recommended Rafter span (mm)							
		Single span				Continuous span			
120x45	10	3900	3800	3700	3600	4900	4900	4900	4300
	20	3900	3800	3700	3600	4900	4900	4900	4500
	40	3900	3600	3200	2900	4900	4900	4300	3900
	60	3400	3200	2800	2500	4700	4300	3800	3500
160x45	10	5500	5500	5300	5200	6600	6600	6600	5900
	20	5500	5500	5100	4700	6600	6600	6600	6100
	40	5100	4700	4200	3800	6600	6300	5700	5200
	60	4500	4200	3700	3400	6100	5700	5000	4600
200x45	10	6900	6700	6500	6100	8200	8200	8200	7500
	20	6900	6600	6200	5800	8200	8200	7800	7300
	40	6200	5800	5200	4800	7800	7300	6700	6300
	60	5600	5200	4600	4200	7200	6700	6200	5700
240x45	10	8100	8000	7500	7000	9900	9900	9500	8800
	20	7800	7500	7000	6600	9800	9400	8800	8300
	40	7000	6600	6100	5700	8800	8300	7700	7200
	60	6500	6100	5500	5000	8100	7700	7000	6600
280x45	10	9300	9100	8400	7800	11500	11300	10600	9900
	20	8600	8300	7800	7400	10800	10500	9700	9300
	40	7800	7400	6800	6400	9700	9300	8600	8100
	60	7200	6800	6200	5800	9000	8600	7900	7400
300x45	10	9700	9400	8900	8300	12000	11800	11200	10400
	20	9000	8700	8100	7700	11300	10900	10200	9800
	40	8100	7700	7100	6700	10200	9800	9000	8500
	60	7500	7200	6600	6200	9500	9000	8300	7800
320x45	10	10100	9800	9400	8700	12000	12000	11800	10900
	20	9400	9000	8500	8100	11800	11400	10700	10200
	40	8500	8100	7500	7100	10600	10200	9400	8900
	60	7900	7500	6900	6500	9900	9400	8600	8100
360x45	10	10700	10500	10100	9500	12000	12000	12000	11900
	20	10100	9800	9200	8700	12000	12000	11600	11000
	40	9200	8700	8100	7700	11600	11000	10200	9600
	60	8500	8100	7500	7000	10700	10200	9400	8800
400x45	10	11500	11200	10800	10300	12000	12000	12000	12000
	20	10700	10400	9800	9400	12000	12000	12000	11800
	40	9900	9400	8700	8300	12000	11800	11000	10400
	60	9200	8700	8100	7600	11600	11000	10100	9500
120x70	10	4500	4500	4300	4200	5500	5500	5500	5200
	20	4500	4500	4200	3900	5500	5500	5500	5300
	40	4200	3900	3500	3200	5500	5300	4700	4300
	60	3800	3500	3100	2800	5100	4700	4200	3800
160x70	10	6200	6100	5900	5600	7300	7300	7300	7000
	20	6200	6000	5500	5100	7300	7300	7000	6700
	40	5500	5100	4600	4200	7000	6700	6100	5700
	60	4900	4600	4100	3700	6500	6100	5500	5100
200x70	10	7600	7500	7100	6600	9200	9200	9000	8300
	20	7100	6900	6500	6200	9000	8700	8100	7800
	40	6500	6200	5600	5200	8100	7800	7200	6800
	60	6000	5600	5000	4600	7600	7200	6600	6200
240x70	10	8500	8400	8000	7600	10800	10500	10100	9500
	20	8000	7800	7300	7000	10100	9800	9200	8800
	40	7300	7000	6500	6100	9200	8800	8100	7700
	60	6800	6500	6000	5500	8600	8200	7500	7100

## Single/continuous span roof rafter- AS 4055 classification N1, N2 and N3 - without ceiling attached (Cont'd)

Rafter spacing (mm)		450	600	900	1200	450	600	900	1200
Member size DxB (mm)	Roof mass (kg/m <sup>2</sup> )	Maximum recommended Rafter span (mm)							
		Single span				Continuous span			
280x70	10	9300	9200	8800	8500	11800	11500	11100	10800
	20	8800	8600	8100	7800	11100	10800	10200	9800
	40	8100	7800	7200	6800	10100	9800	9100	8600
	60	7600	7200	6700	6300	9500	9100	8400	7900
300x70	10	9700	9500	9200	8900	12000	12000	11600	11200
	20	9200	8900	8400	8100	11600	11200	10600	10200
	40	8500	8100	7500	7200	10600	10200	9500	9000
	60	7900	7600	7000	6600	10000	9500	8800	8300
320x70	10	10000	9800	9600	9300	12000	12000	12000	11700
	20	9600	9300	8800	8500	12000	11700	11100	10700
	40	8800	8500	7900	7500	11100	10700	9900	9400
	60	8300	7900	7300	6900	10400	10000	9200	8700
360x70	10	10700	10500	10300	10000	12000	12000	12000	12000
	20	10300	10000	9500	9100	12000	12000	11900	11500
	40	9500	9100	8500	8100	11900	11500	10700	10200
	60	8900	8600	7900	7500	11300	10700	10000	9400
400x70	10	11400	11200	10900	10600	12000	12000	12000	12000
	20	10900	10600	10200	9800	12000	12000	12000	12000
	40	10200	9800	9200	8700	12000	12000	11600	11000
	60	9600	9200	8500	8100	12000	11600	10700	10200
440x70	10	12000	11800	11500	11300	12000	12000	12000	12000
	20	11500	11300	10700	10400	12000	12000	12000	12000
	40	10700	10400	9800	9300	12000	12000	12000	11700
	60	10200	9800	9100	8600	12000	12000	11500	10800
200x90	10	7800	7700	7400	7100	9900	9700	9300	8900
	20	7400	7100	6700	6500	9300	9000	8500	8100
	40	6800	6400	6000	5600	8500	8100	7500	7100
	60	6300	6000	5400	5000	7900	7600	7000	6600
240x90	10	8700	8500	8300	8000	10900	10700	10400	10100
	20	8300	8000	7600	7300	10300	10100	9500	9200
	40	7600	7300	6800	6400	9500	9200	8500	8100
	60	7100	6800	6300	5900	8900	8600	7900	7500
280x90	10	9500	9300	9000	8800	11900	11700	11400	11100
	20	9000	8800	8400	8100	11300	11100	10500	10100
	40	8400	8100	7500	7200	10500	10100	9500	9000
	60	7900	7600	7000	6600	9900	9500	8800	8300
300x90	10	9800	9600	9400	9200	12000	12000	11800	11500
	20	9400	9200	8700	8400	11800	11500	11000	10600
	40	8800	8400	7900	7500	11000	10600	9900	9500
	60	8200	7900	7300	6900	10400	10000	9200	8700
320x90	10	10200	10100	9800	9500	12000	12000	12000	12000
	20	9800	9500	9100	8800	12000	12000	11500	11100
	40	9100	8800	8200	7900	11500	11100	10400	9900
	60	8600	8300	7700	7300	10800	10400	9600	9100
360x90	10	10900	10700	10500	10200	12000	12000	12000	12000
	20	10400	10200	9800	9500	12000	12000	12000	11900
	40	9800	9500	8900	8500	12000	11900	11200	10700
	60	9300	8900	8300	7900	11700	11200	10500	9900
400x90	10	11500	11300	11100	10900	12000	12000	12000	12000
	20	11100	10900	10500	10100	12000	12000	12000	12000
	40	10400	10100	9500	9100	12000	12000	12000	11500
	60	9900	9600	8900	8500	12000	12000	11200	10700
440x90	10	12000	12000	11700	11500	12000	12000	12000	12000
	20	11700	11500	11100	10700	12000	12000	12000	12000
	40	11000	10700	10100	9700	12000	12000	12000	12000
	60	10500	10200	9500	9100	12000	12000	12000	11400

## Single/continuous span roof rafter AS 4055 classification C1, C2 and C3 - without ceiling attached

Rafter spacing (mm)		450	600	900	1200	450	600	900	1200
Member size DxB (mm)	Roof mass (kg/m <sup>2</sup> )	Maximum recommended Rafter span (mm)							
		Single span				Continuous span			
120x45	10	3900	3400	2700	2200	4000	3400	2700	2200
	20	3900	3500	2700	2200	4100	3500	2700	2200
	40	3900	3500	2800	2300	4200	3500	2800	2300
	60	3400	3200	2800	2300	4200	3600	2800	2300
160x45	10	5400	4600	3700	3100	5400	4600	3700	3100
	20	5400	4700	3700	3100	5500	4700	3700	3100
	40	5100	4700	3800	3200	5600	4800	3800	3200
	60	4500	4200	3700	3200	5700	4900	3900	3200
200x45	10	6400	5800	4700	3900	6800	5800	4700	3900
	20	6400	5900	4700	4000	6900	5900	4700	4000
	40	6200	5800	4800	4000	7000	6000	4800	4000
	60	5600	5200	4600	4100	7200	6100	4900	4100
240x45	10	7300	6800	5600	4800	8200	7000	5600	4800
	20	7300	6800	5700	4800	8300	7100	5700	4800
	40	7000	6600	5800	4900	8500	7300	5800	4900
	60	6500	6100	5500	5000	8100	7400	5900	5000
280x45	10	8200	7700	6600	5600	9600	8200	6600	5600
	20	8200	7700	6700	5700	9700	8300	6700	5700
	40	7800	7400	6800	5800	9700	8500	6800	5800
	60	7200	6800	6200	5800	9000	8600	7000	5900 <sub>5</sub>
300x45	10	8700	8100	7100	6000	10300	8900	7100	6000
	20	8700	8100	7200	6100	10400	8900	7200	6100
	40	8100	7700	7100	6200	10300	9100	7300	6200 <sub>5</sub>
	60	7600	7100	6600	6200	9500	9000	7500	6400 <sub>10</sub>
320x45	10	9100	8500	7600	6500	11000	9500	7600	6500
	20	9100	8500	7700	6500	11200	9600	7700	6500
	40	8500	8100	7500	6700	10700	9800	7800	6700 <sub>10</sub>
	60	7900	7500	6900	6500	9900	9400	8000 <sub>5</sub>	6800 <sub>15</sub>
360x45	10	10000	9300	8400	7300	12000	10700	8600	7300 <sub>10</sub>
	20	9900	9300	8400	7400	12000	10800	8700 <sub>5</sub>	7400 <sub>10</sub>
	40	9200	8700	8100	7500	11600	11000	8900 <sub>10</sub>	7600 <sub>15</sub>
	60	8600	8100	7500	7000	10700	10200	9100 <sub>15</sub>	7700 <sub>20</sub>
400x45	10	10800	10000	9100	8200	12000	11900	9600 <sub>10</sub>	8200 <sub>15</sub>
	20	10700	10000	9100	8200	12000	12000	9700 <sub>10</sub>	8300
	40	9800	9400	8700	8300	12000	11800	9900 <sub>15</sub>	8400 <sub>25</sub>
	60	9200	8700	8100	7600	11600	11000	10100 <sub>20</sub>	8600 <sub>30</sub>
120x70	10	4500	4100	3200	2700	4800	4100	3200	2700
	20	4500	4100	3300	2700	4800	4100	3300	2700
	40	4200	3900	3300	2800	4900	4200	3300	2800
	60	3800	3500	3100	2800	5000	4300	3400	2800
160x70	10	5900	5500	4400	3700	6400	5500	4400	3700
	20	5900	5500	4400	3700	6500	5600	4400	3700
	40	5500	5100	4500	3800	6600	5700	4500	3800
	60	4900	4600	4100	3700	6500	5800	4600	3900
200x70	10	7000	6500	5500	4700	8100	6900	5500	4700
	20	6900	6500	5600	4700	8200	7000	5600	4700
	40	6500	6200	5600	4800	8100	7100	5700	4800
	60	6000	5600	5000	4600	7600	7200	5800	4900
240x70	10	8000	7400	6700	5700	9800	8400	6700	5700
	20	8000	7400	6700	5700	9900	8400	6800	5700
	40	7300	7000	6500	5900	9200	8600	6900	5900
	60	6800	6500	6000	5500	8600	8200	7100	6000
280x70	10	8900	8300	7500	6700	11200	9800	7900	6700
	20	8800	8300	7500	6800	11100	9900	7900	6800
	40	8100	7800	7200	6800	10100	9800	8100	6900
	60	7600	7200	6700	6300	9500	9100	8300	7100
300x70	10	9400	8800	7900	7200	11800	10500	8400	7200
	20	9200	8800	7900	7300	11600	10600	8500	7300
	40	8500	8100	7500	7200	10600	10200	8700	7400
	60	8000	7600	7000	6600	10000	9500	8800	7600
320x70	10	9900	9200	8300	7700	12000	11300	9000	7700
	20	9500	9200	8300	7700	12000	11400	9100	7800
	40	8800	8500	7900	7500	11100	10700	9300	7900
	60	8300	7900	7300	6900	10400	10000	9200	8100
360x70	10	10700	10100	9100	8400	12000	12000	10200	8700
	20	10200	10000	9100	8400	12000	12000	10300	8800
	40	9500	9100	8500	8100	11900	11500	10500	9000
	60	9000	8500	7900	7500	11300	10700	10000	9200 <sub>5</sub>

## Single/continuous span roof rafter AS 4055 classification C1, C2 and C3 - without ceiling attached (Cont'd)

Rafter spacing (mm)		450	600	900	1200	450	600	900	1200
Member size DxB (mm)	Roof mass (kg/m <sup>2</sup> )	Maximum recommended Rafter span (mm)							
		Single span				Continuous span			
400x70	10	11400	10900	9800	9100	12000	12000	11400	9700
	20	10900	10600	9800	9100	12000	12000	11500	9800
	40	10100	9800	9200	8700	12000	12000	11600	10000 <sub>10</sub>
	60	9600	9200	8500	8100	12000	11600	10700	10200 <sub>10</sub>
440x70	10	12000	11700	10500	9800	12000	12000	12000	10700 <sub>5</sub>
	20	11500	11300	10600	9800	12000	12000	12000	10800 <sub>10</sub>
	40	10800	10400	9800	9300	12000	12000	12000	11100 <sub>15</sub>
	60	10200	9800	9100	8600	12000	12000	11500	10800 <sub>15</sub>
200x90	10	7400	6900	6200	5400	9200	7900	6300	5400
	20	7400	6900	6200	5400	9300	8000	6400	5400
	40	6800	6400	6000	5500	8500	8100	6500	5500
	60	6300	6000	5400	5000	7900	7600	6700	5700
240x90	10	8500	7900	7100	6500	10700	9500	7600	6500
	20	8200	7900	7100	6600	10300	9600	7700	6600
	40	7600	7300	6800	6400	9500	9200	7900	6700
	60	7100	6800	6300	5900	8900	8600	7900	6900
280x90	10	9400	8900	8000	7500	11900	11200	9000	7600
	20	9000	8800	8000	7500	11300	11100	9100	7700
	40	8400	8100	7500	7200	10500	10100	9300	7900
	60	7900	7600	7000	6600	9900	9500	8800	8100
300x90	10	9800	9400	8400	7800	12000	11800	9600	8200
	20	9400	9200	8400	7800	11800	11500	9700	8300
	40	8800	8400	7900	7500	11000	10600	9900	8500
	60	8300	7900	7300	6900	10400	10000	9200	8700
320x90	10	10200	9800	8800	8200	12000	12000	10300	8800
	20	9800	9500	8900	8200	12000	12000	10400	8900
	40	9100	8800	8200	7900	11500	11100	10400	9100
	60	8600	8300	7700	7300	10800	10400	9600	9100
360x90	10	10900	10700	9700	9000	12000	12000	11700	9900
	20	10500	10200	9700	9000	12000	12000	11800	10000
	40	9800	9500	8900	8500	12000	11900	11200	10300
	60	9300	8900	8300	7900	11700	11200	10500	9900
400x90	10	11500	11300	10500	9700	12000	12000	12000	11100
	20	11100	10900	10500	9700	12000	12000	12000	11200
	40	10400	10100	9500	9100	12000	12000	12000	11500
	60	9900	9600	8900	8500	12000	12000	11200	10700
440x90	10	12000	12000	11200	10500	12000	12000	12000	12000
	20	11700	11500	11100	10500	12000	12000	12000	12000
	40	11000	10700	10100	9700	12000	12000	12000	12000 <sub>5</sub>
	60	10500	10200	9500	9100	12000	12000	12000	11400 <sub>5</sub>

### NOTES:

1. D = member depth, B = member breadth, NS = not suitable.
2. The above table was based on a batten spacing of 900 mm
3. Maximum birds mouth depth = 30 % of rafter depth
4. End bearing lengths = 45 mm at end supports and 45 mm at internal supports for continuous members. Subscript values Indicate the minimum additional bearing length where required to be greater than 45 mm at end supports and 45 mm at internal supports
5. Construction loads shall not be applied to overhangs until a 190 x 19 (minimum) timber fascia or other fascia of equivalent stiffness is rigidly and permanently attached to the end of rafter overhangs
6. Rafter spacing up to 1200 mm
7. Not all sizes of SmartLam GLT15S in this table are stocked in each state. Please check with your supplier before ordering
8. Table does not list all available SmartLam GLT15S sizes. See page 11 for full list of sizes

## Ridge/intermediate roof beam AS 4055 classification N1, N2 and N3

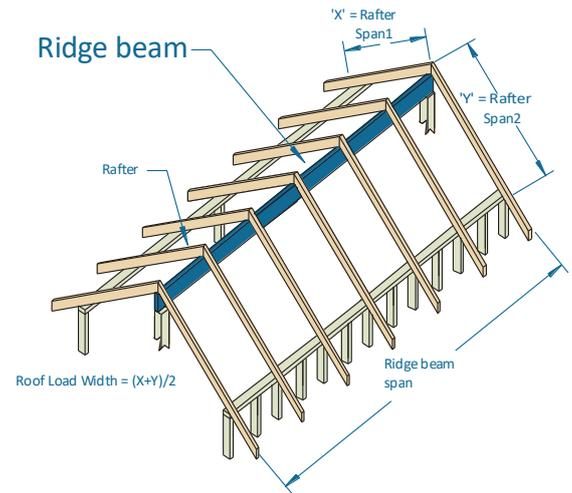
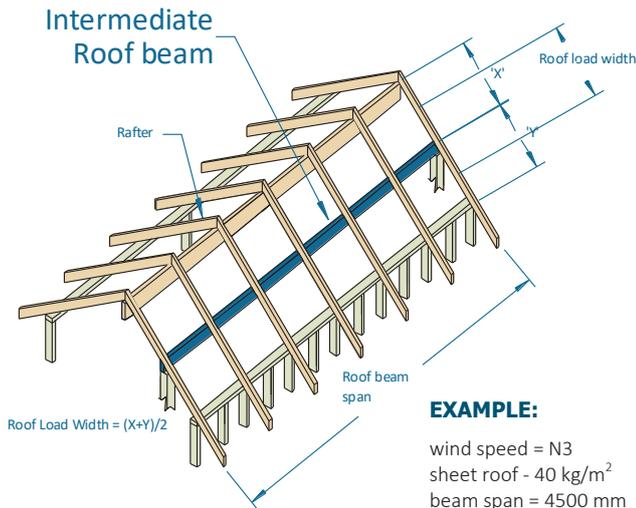

### EXAMPLE:

wind speed = N3  
 sheet roof - 40 kg/m<sup>2</sup>  
 beam span = 4500 mm  
 X = 2000 mm Y = 3000 mm  
 roof load width =  $(X+Y)/2 = 2500$  mm  
 Enter single span table at 3000 roof load width with  
 column and read down to span equal to or greater  
 than 4500 mm in 40 kg/m<sup>2</sup> row

ADOPT: SmartLam GLT15S - 280 x 45

Roof load width (mm)		1500	3000	4500	6000	7500	1500	3000	4500	6000	7500
Member size DxB (mm)	Roof mass (kg/m <sup>2</sup> )	Maximum recommended Ridge /Intermediate beam span (mm)									
		Single span					Continuous span				
120x45	40	2600	2000	1700	1600	1400	3600	2500	2000	1700	1500
	90	2000	1600	1400	1200	1100	2800	2000	1600	1300	1200
160x45	40	3500	2700	2300	2100	1900	4800	3300	2600	2300	2000
	90	2700	2100	1800	1700	1500	3700	2700	2100	1800	1600
200x45	40	4400	3400	2900	2600	2400	5900	4100	3300	2800	2500
	90	3400	2700	2300	2100	1900	4600	3300	2700	2300	2000
240x45	40	5200	4100	3500	3100	2900	6800	4900	4000	3400	3000
	90	4100	3200	2800	2500	2300	5600	4000	3200	2700	2400
280x45	40	6000	4800	4100	3700	3300	7600	5700	4600	4000	3500
	90	4800	3800	3300	2900	2700	6300	4600	3700	3200	2800 <sub>10</sub>
300x45	40	6300	5100	4400	3900	3600	7900	6200	5000	4300	3800
	90	5100	4000	3500	3100	2900	6700	5000	4000	3400 <sub>5</sub>	3000 <sub>15</sub>
320x45	40	6600	5500	4700	4200	3800	8300	6600	5300	4500	4000
	90	5400	4300	3700	3400	3100	7000	5300	4300	3700 <sub>10</sub>	3200 <sub>25</sub>
360x45	40	7200	6100	5300	4700	4300	9000	7500	6000	5100	4500 <sub>10</sub>
	90	6100	4800	4200	3800	3500	7600	5900	4800 <sub>5</sub>	4100 <sub>25</sub>	3600 <sub>40</sub>
400x45	40	7800	6600	5900	5200	4800	9800	8200	6600	5700 <sub>10</sub>	5000 <sub>25</sub>
	90	6600	5400	4700	4200	3900	8200	6700	5300 <sub>20</sub>	4600 <sub>40</sub>	4000 <sub>70</sub>
120x70	40	2900	2300	1900	1700	1600	4000	2900	2300	2000	1800
	90	2300	1800	1500	1400	1300	3100	2300	1900	1600	1400
160x70	40	3800	3000	2600	2300	2100	5200	3900	3100	2700	2400
	90	3000	2400	2100	1900	1700	4100	3100	2500	2100	1900
200x70	40	4800	3800	3300	2900	2700	6300	4800	3900	3300	3000
	90	3800	3000	2600	2300	2100	5100	3900	3100	2700	2400
240x70	40	5700	4500	3900	3500	3200	7200	5800	4700	4000	3500
	90	4500	3600	3100	2800	2600	6100	4600	3800	3200	2800
280x70	40	6400	5300	4600	4100	3700	8100	6800	5400	4700	4100
	90	5300	4200	3600	3300	3000	6800	5400	4400	3800	3300
300x70	40	6800	5600	4900	4400	4000	8500	7200	5800	5000	4400
	90	5600	4500	3900	3500	3200	7200	5800	4700	4000	3600
320x70	40	7100	6000	5200	4700	4300	8900	7600	6200	5300	4700
	90	6000	4800	4100	3700	3400	7500	6200	5000	4300	3800
360x70	40	7700	6500	5800	5200	4800	9700	8200	7000	6000	5300
	90	6500	5400	4700	4200	3900	8200	6900	5600	4800	4300 <sub>10</sub>
400x70	40	8200	7100	6300	5800	5300	10300	8900	7700	6600	5900
	90	7000	6000	5200	4700	4300	8800	7500	6200	5300 <sub>5</sub>	4700 <sub>20</sub>
440x70	40	8800	7600	6800	6300	5800	11100	9500	8500	7300	6500 <sub>5</sub>
	90	7500	6400	5700	5100	4700	9400	8100	6800	5900 <sub>15</sub>	5200 <sub>30</sub>

## Ridge/intermediate roof beam AS 4055 classification N1, N2 & N3 (Cont'd)

Roof load width (mm)		1500	3000	4500	6000	7500	1500	3000	4500	6000	7500
Member size DxB (mm)	Roof mass (kg/m <sup>2</sup> )	Maximum recommended Ridge /Intermediate beam span (mm)									
		Single span					Continuous span				
200x90	40	5100	4100	3500	3200	2900	6700	5400	4400	3800	3300
	90	4100	3200	2800	2500	2300	5600	4400	3600	3000	2700
240x90	40	6100	4900	4200	3800	3500	7600	6500	5300	4500	4000
	90	4900	3900	3400	3000	2800	6500	5200	4300	3600	3200
280x90	40	6800	5700	4900	4400	4000	8500	7300	6100	5300	4700
	90	5700	4500	3900	3600	3300	7200	6100	4900	4200	3800
300x90	40	7100	6100	5300	4700	4300	8900	7600	6600	5700	5000
	90	6000	4900	4200	3800	3500	7600	6400	5300	4500	4000
320x90	40	7400	6300	5600	5000	4600	9300	8000	7000	6000	5300
	90	6300	5200	4500	4100	3700	7900	6800	5600	4800	4300
360x90	40	8000	6900	6200	5700	5200	10200	8700	7800	6800	6000
	90	6900	5800	5100	4600	4200	8600	7400	6300	5400	4800
400x90	40	8600	7400	6700	6200	5800	10900	9400	8400	7500	6700
	90	7400	6300	5600	5100	4700	9300	8000	7000	6000	5300 <sub>5</sub>
440x90	40	9200	7900	7200	6600	6200	11700	10000	9000	8200	7300
	90	8000	6800	6100	5600	5100	10000	8500	7700	6600	5900 <sub>15</sub>
240x120	40	6400	5300	4600	4200	3800	8100	6900	6100	5200	4600
	90	5300	4300	3700	3300	3100	6900	5800	4900	4200	3700
280x120	40	7100	6100	5400	4800	4400	9000	7700	6900	6100	5400
	90	6100	5000	4300	3900	3600	7700	6500	5700	4900	4300
300x120	40	7500	6400	5800	5200	4700	9400	8100	7300	6500	5800
	90	6400	5300	4600	4200	3900	8100	6900	6100	5200	4600
320x120	40	7800	6700	6100	5500	5100	9900	8500	7600	6900	6100
	90	6700	5700	4900	4500	4100	8400	7200	6500	5600	4900
360x120	40	8500	7300	6600	6100	5700	10600	9200	8300	7700	6900
	90	7300	6200	5500	5000	4600	9200	7900	7100	6200	5500
400x120	40	9100	7900	7100	6600	6200	11500	9900	9000	8300	7700
	90	7900	6800	6100	5600	5100	9900	8500	7700	6900	6100
440x120	40	9700	8400	7600	7100	6700	12000	10600	9600	8900	8400
	90	8500	7200	6500	6100	5600	10600	9100	8200	7600	6700
240x140	40	6600	5600	4900	4400	4000	8300	7200	6400	5600	5000
	90	5600	4500	3900	3500	3200	7100	6100	5300	4500	4000
280x140	40	7300	6300	5600	5100	4700	9200	7900	7200	6500	5800
	90	6300	5200	4500	4100	3800	7900	6800	6100	5300	4700
300x140	40	7700	6600	6000	5400	5000	9700	8300	7600	7000	6200
	90	6600	5600	4900	4400	4000	8300	7100	6400	5600	5000
320x140	40	8000	6900	6300	5800	5300	10200	8800	7900	7300	6600
	90	7000	5900	5200	4700	4300	8700	7500	6700	6000	5300
360x140	40	8700	7500	6800	6300	6000	10900	9500	8600	8000	7400
	90	7500	6500	5800	5300	4900	9500	8200	7300	6700	6000
400x140	40	9300	8100	7400	6800	6400	11800	10200	9300	8600	8100
	90	8200	7000	6300	5800	5400	10300	8800	7900	7400	6600
440x140	40	9900	8700	7900	7300	6900	12000	10900	9900	9200	8700
	90	8700	7500	6800	6300	5900	10900	9400	8500	7900	7200

### NOTES:

1. D = member depth, B = member breadth, NS = not suitable
2. End bearing lengths = 70 mm at end supports and 90 mm at internal supports for continuous members. Subscript values indicate the minimum additional bearing length where required to be greater than 70 mm at end supports and 90 mm at internal supports
3. Rafter spacing up to 1200 mm
4. Not all sizes of SmartLam GLT15S in this table are stocked in each state. Please check with your supplier before ordering
5. Table does not list all available SmartLam GLT15S sizes. See page 10 for full list of sizes

## Ridge/intermediate roof beam AS 4055 classification C1, C2 and C3

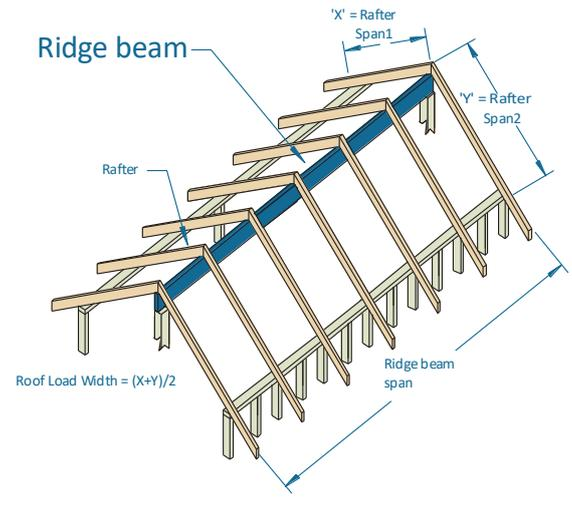
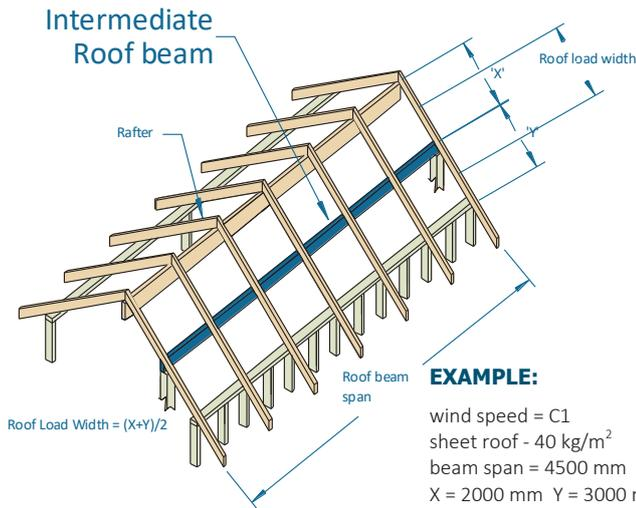

**EXAMPLE:**

wind speed = C1  
 sheet roof - 40 kg/m<sup>2</sup>  
 beam span = 4500 mm  
 X = 2000 mm Y = 3000 mm  
 roof load width =  $(X+Y)/2 = 2500$  mm  
 Enter single span table at 3000 roof load width with  
 column and read down to span equal to or greater  
 than 4500 mm in 40 kg/m<sup>2</sup> row

**ADOPT:** SmartLam GLT15S - 400x 45

Roof load width (mm)		1500	3000	4500	6000	7500	1500	3000	4500	6000	7500
Member size DxB (mm)	Roof mass (kg/m <sup>2</sup> )	Maximum recommended Ridge /Intermediate beam span (mm)									
		Single span					Continuous span				
120x45	40	2000	1400	1200	1000	NS	2000	1400	1200	1000	NS
	90	2000	1400	1200	1000	NS	2100	1400	1200	1000	NS
160x45	40	2700	1900	1600	1400	1200	2700	1900	1600	1400	1200
	90	2700	1900	1600	1300	1200	2800	1900	1600	1300	1200
200x45	40	3500	2400	2000	1700	1500	3500	2400	2000	1700	1500
	90	3400	2400	2000	1700	1500	3500	2400	2000	1700	1500
240x45	40	4300	2900	2400	2100	1800	4300	2900	2400	2100	1800 <sub>5</sub>
	90	4100	2900	2400	2000	1800	4300	2900	2400	2000 <sub>10</sub>	1800 <sub>20</sub>
280x45	40	5100	3400	2800	2400	2200	5100	3400	2800	2400 <sub>10</sub>	2100 <sub>25</sub>
	90	4800	3400	2800	2400	2100	5100	3400	2800 <sub>10</sub>	2400 <sub>30</sub>	2100 <sub>45</sub>
300x45	40	5500	3700	3000	2600	2300	5500	3700	3000 <sub>5</sub>	2600 <sub>20</sub>	2300 <sub>35</sub>
	90	5100	3700	3000	2600	2300	5500	3700	3000 <sub>20</sub>	2600 <sub>40</sub>	2200 <sub>65</sub>
320x45	40	5900	3900	3200	2800	2500	5900	3900	3200 <sub>10</sub>	2800 <sub>30</sub>	2400 <sub>40</sub>
	90	5400	3900	3200	2700	2400	5900	3900 <sub>5</sub>	3200 <sub>25</sub>	2700 <sub>55</sub>	2400 <sub>75</sub>
360x45	40	6700	4400	3600	3100	2800	6700	4400	3600 <sub>25</sub>	3100 <sub>50</sub>	2700 <sub>70</sub>
	90	6100	4400	3600	3100	2700 <sub>5</sub>	6600	4400 <sub>15</sub>	3600 <sub>50</sub>	3100 <sub>80</sub>	2600 <sub>95</sub>
400x45	40	7400	4900	4000	3500	3100 <sub>5</sub>	7400	4900 <sub>10</sub>	4000 <sub>40</sub>	3500 <sub>75</sub>	3000 <sub>90</sub>
	90	6600	4900	4000	3400 <sub>5</sub>	3000 <sub>15</sub>	7400	4900 <sub>30</sub>	4000 <sub>70</sub>	3400 <sub>95</sub>	2900 <sub>115</sub>
120x70	40	2400	1700	1400	1200	1100	2400	1700	1400	1200	1100
	90	2300	1700	1400	1200	1000	2400	1700	1400	1200	1000
160x70	40	3300	2300	1900	1600	1400	3300	2300	1900	1600	1400
	90	3000	2300	1800	1600	1400	3300	2300	1800	1600	1400
200x70	40	4200	2900	2300	2000	1800	4200	2900	2300	2000	1800
	90	3800	2900	2300	2000	1800	4200	2900	2300	2000	1800
240x70	40	5100	3500	2800	2400	2200	5100	3500	2800	2400	2200
	90	4500	3400	2800	2400	2100	5100	3400	2800	2400	2100
280x70	40	6100	4000	3300	2900	2600	6100	4000	3300	2900	2600
	90	5300	4000	3300	2800	2500	6000	4000	3300	2800	2500 <sub>10</sub>
300x70	40	6500	4300	3500	3100	2700	6500	4300	3500	3100	2700 <sub>5</sub>
	90	5600	4300	3500	3000	2700	6500	4300	3500	3000 <sub>5</sub>	2700 <sub>15</sub>
320x70	40	7000	4600	3800	3300	2900	7000	4600	3800	3300	2900 <sub>10</sub>
	90	6000	4600	3700	3200	2900	6900	4600	3700	3200 <sub>10</sub>	2900 <sub>25</sub>
360x70	40	7600	5200	4200	3700	3300	7900	5200	4200	3700 <sub>10</sub>	3300 <sub>25</sub>
	90	6500	5100	4200	3600	3200	7800	5100	4200 <sub>10</sub>	3600 <sub>25</sub>	3200 <sub>40</sub>
400x70	40	8300	5800	4700	4100	3700	8900	5800	4700 <sub>5</sub>	4100 <sub>20</sub>	3700 <sub>40</sub>
	90	7000	5700	4700	4000	3600	8700	5700	4700 <sub>20</sub>	4000 <sub>40</sub>	3600 <sub>70</sub>
440x70	40	8800	6400	5200	4500	4000	9800	6400	5200 <sub>15</sub>	4500 <sub>35</sub>	4000 <sub>65</sub>
	90	7500	6300	5100	4400	3900	9400	6300 <sub>10</sub>	5100 <sub>30</sub>	4400 <sub>65</sub>	3900 <sub>85</sub>

## Ridge/intermediate roof beam AS 4055 classification C1, C2 & C3 (Cont'd)

Roof load width (mm)		1500	3000	4500	6000	7500	1500	3000	4500	6000	7500
Member size DxB (mm)	Roof mass (kg/m <sup>2</sup> )	Maximum recommended Ridge /Intermediate beam span (mm)									
		Single span					Continuous span				
200x90	40	4800	3300	2700	2300	2100	4800	3300	2700	2300	2100
	90	4100	3200	2600	2300	2000	4800	3200	2600	2300	2000
240x90	40	5900	3900	3200	2800	2500	5900	3900	3200	2800	2500
	90	4900	3900	3200	2700	2400	5800	3900	3200	2700	2400
280x90	40	6700	4600	3700	3200	2900	7000	4600	3700	3200	2900
	90	5700	4500	3700	3200	2800	6800	4500	3700	3200	2800
300x90	40	7100	4900	4000	3500	3100	7500	4900	4000	3500	3100
	90	6000	4900	4000	3400	3000	7400	4900	4000	3400	3000 <sub>5</sub>
320x90	40	7400	5200	4300	3700	3300	8000	5200	4300	3700	3300
	90	6300	5200	4200	3600	3300	7900	5200	4200	3600	3300 <sub>10</sub>
360x90	40	8100	5900	4800	4200	3700	9100	5900	4800	4200	3700 <sub>10</sub>
	90	6900	5800	4700	4100	3700	8600	5800	4700	4100 <sub>10</sub>	3700 <sub>25</sub>
400x90	40	8600	6600	5400	4600	4200	10100	6600	5400	4600 <sub>10</sub>	4200 <sub>25</sub>
	90	7400	6300	5300	4600	4100	9300	6500	5300 <sub>5</sub>	4600 <sub>25</sub>	4100 <sub>40</sub>
440x90	40	9200	7400	5900	5100	4600	11200	7400	5900 <sub>5</sub>	5100 <sub>20</sub>	4600 <sub>35</sub>
	90	7900	6800	5800	5000	4500	10000	7300	5800 <sub>15</sub>	5000 <sub>35</sub>	4500 <sub>65</sub>
200x120	40	5600	3800	3100	2700	2400	5700	3800	3100	2700	2400
	90	4500	3600	3000	2600	2300	5600	3700	3000	2600	2300
240x120	40	6400	4500	3700	3200	2900	6900	4500	3700	3200	2900
	90	5300	4300	3700	3200	2800	6800	4500	3700	3200	2800
280x120	40	7100	5300	4300	3800	3400	8100	5300	4300	3800	3400
	90	6100	5000	4300	3700	3300	7700	5200	4300	3700	3300
300x120	40	7500	5700	4600	4000	3600	8700	5700	4600	4000	3600
	90	6400	5300	4600	3900	3500	8100	5600	4600	3900	3500
320x120	40	7800	6100	4900	4300	3800	9400	6100	4900	4300	3800
	90	6700	5700	4900	4200	3800	8400	6000	4900	4200	3800
360x120	40	8500	6900	5600	4800	4300	10600	6900	5600	4800	4300
	90	7300	6200	5500	4700	4200	9200	6800	5500	4700	4200 <sub>5</sub>
400x120	40	9100	7800	6200	5400	4800	11500	7800	6200	5400	4800 <sub>5</sub>
	90	7900	6800	6100	5200	4700	9900	7700	6100	5200 <sub>5</sub>	4700 <sub>20</sub>
440x120	40	9700	8400	6800	5900	5300	12000	8700	6800	5900 <sub>5</sub>	5300 <sub>15</sub>
	90	8400	7200	6500	5800	5100	10600	8500	6700	5800 <sub>20</sub>	5100 <sub>30</sub>
240x140	40	6600	4900	4000	3500	3100	7500	4900	4000	3500	3100
	90	5600	4500	3900	3400	3000	7100	4800	3900	3400	3000
280x140	40	7300	5700	4700	4100	3600	8800	5700	4700	4100	3600
	90	6300	5200	4500	4000	3500	7900	5600	4600	4000	3500
300x140	40	7700	6200	5000	4300	3900	9500	6200	5000	4300	3900
	90	6600	5600	4900	4300	3800	8400	6000	4900	4300	3800
320x140	40	8000	6600	5300	4600	4200	10100	6600	5300	4600	4200
	90	7000	5900	5200	4500	4000	8700	6500	5200	4500	4000
360x140	40	8700	7600	6000	5200	4700	10900	7600	6000	5200	4700
	90	7500	6500	5800	5100	4600	9500	7400	5900	5100	4600
400x140	40	9300	8100	6700	5800	5200	11800	8500	6700	5800	5200
	90	8100	7000	6300	5700	5100	10200	8300	6500	5700	5100 <sub>10</sub>
440x140	40	10000	8700	7400	6400	5700	12000	9500	7400	6400	5700 <sub>10</sub>
	90	8700	7500	6800	6200	5600	10900	9200	7200	6200 <sub>10</sub>	5600 <sub>20</sub>

### NOTES:

1. D = member depth, B = member breadth, NS = not suitable
2. End bearing lengths = 70 mm at end supports and 90 mm at internal supports for continuous members. Subscript values indicate the minimum additional bearing length where required to be greater than 70 mm at end supports and 90 mm at internal supports
3. Rafter spacing up to 1200 mm
4. Not all sizes of SmartLam GLT15S in this table are stocked in each state. Please check with your supplier before ordering
5. Table does not list all available SmartLam GLT15S sizes. See page 11 for full list of sizes

## Verandah beam (single span) AS 4055 classification N1, N2 and N3

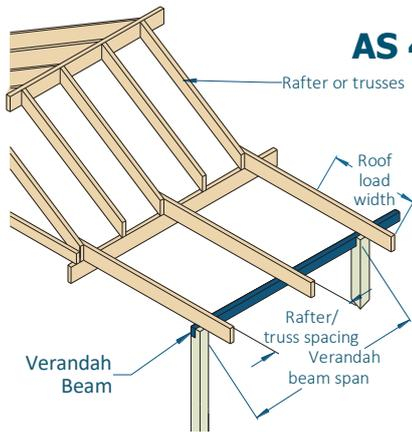

### EXAMPLE:

wind speed = N3  
 sheet roof - 40 kg/m<sup>2</sup>  
 rafter/truss spacing = 600 mm  
 verandah span = 3500 mm (single span)  
 roof load width = 3900 mm

Enter span table at 4500 roof load width column, rafter spacing of 600 mm, and read down to a span equal to or greater than 3500 mm in 40 kg/m<sup>2</sup> row

### ADOPT:

SmartLam GLT15S - 280 x 45

Roof load width (mm)		1500		3000		4500		6000		7500	
Rafter/truss spacing (mm)		600	1200	600	1200	600	1200	600	1200	600	1200
Member size DxB (mm)	Roof mass (kg/m <sup>2</sup> )	Maximum recommended Verandah beam span (mm)									
		Single span									
120x45	10	3000	2900	2100	1900	1600	1300	1400	1000	1300	NS
	20	2900	2900	2100	2000	1700	1300	1500	1000	1300	NS
	40	2400	2400	1800	1800	1600	1300	1400	NS	1200	NS
	60	2100	2100	1600	1500	1400	1100	1300	NS	1100	NS
	90	1800	1800	1400	1300	1200	1000	1100	NS	NS	NS
160x45	10	4000	3900	2800	2700	2300	2200	1900	1700	1700	1400
	20	3800	3800	2900	2800	2400	2200	2000	1800	1800	1500
	40	3200	3100	2500	2500	2100	2100	1900	1700	1600	1300
	60	2800	2800	2200	2200	1900	1900	1700	1500	1500	1000
	90	2500	2500	1900	1900	1600	1600	1500	1300	1400	NS
200x45	10	5000	5000	3600	3400	2900	2800	2500	2400	2300	2100
	20	4500	4500	3700	3500	2900	2800	2600	2500	2300	2200
	40	3900	3900	3100	3100	2700	2700	2400	2300	2100	2000
	60	3500	3500	2700	2800	2400	2400	2100	2100	1900	1700
	90	3100	3100	2400	2400	2100	2000	1900	1900	1700	1500
240x45	10	5800	5800	4300	4200	3500	3300	3000	2900	2700	2600
	20	5200	5200	4300	4300	3600	3400	3100	3000	2800	2700
	40	4500	4500	3700	3700	3200	3200	2800	2800	2600	2500
	60	4100	4100	3300	3300	2800	2900	2500	2600	2300	2300
	90	3700	3700	2900	2900	2500	2500	2300	2200	2100	1900
280x45	10	6400	6400	5000	5000	4100	4000	3600	3400	3200	3000
	20	5800	5800	4800	4800	4200	4100	3700	3500	3200	3100
	40	5100	5100	4200	4200	3700	3700	3300	3300	3000	2900
	60	4600	4600	3900	3800	3300	3300	3000	3000	2700	2800
	90	4200	4200	3400	3400	2900	2900	2700	2700	2400	2400
300x45	10	6700	6700	5300	5300	4400	4300	3800	3700	3400	3300
	20	6000	6000	5100	5100	4500	4400	3900	3800	3500	3300
	40	5300	5300	4500	4400	4000	4000	3600	3500	3300	3100
	60	4900	4900	4100	4100	3600	3500	3200	3200	2900	2900
	90	4400	4400	3700	3600	3200	3100	2800	2900	2600	2600
120x70	10	3300	3300	2500	2400	2000	1800	1700	1300	1500	1100
	20	3200	3100	2500	2500	2000	1900	1700	1400	1500	1100
	40	2600	2700	2100	2000	1700	1700	1500	1300	1400	1000
	60	2300	2400	1800	1800	1600	1400	1400	1100	1300	NS
	90	2000	2000	1600	1500	1400	1200	1200	1000	1100	NS
160x70	10	4500	4500	3300	3200	2700	2600	2400	2200	2100	2000
	20	4100	4100	3300	3200	2800	2700	2400	2300	2100	2000
	40	3500	3400	2700	2800	2300	2400	2100	2100	1900	1800
	60	3100	3100	2400	2500	2100	2100	1900	1900	1700	1600
	90	2700	2800	2100	2100	1800	1800	1700	1600	1500	1400
200x70	10	5400	5400	4200	4100	3400	3300	3000	2900	2700	2600
	20	4800	4800	4100	4000	3500	3300	3000	2900	2700	2600
	40	4200	4200	3400	3400	2900	2900	2600	2700	2400	2400
	60	3900	3800	3000	3000	2600	2700	2300	2300	2200	2100
	90	3400	3400	2700	2700	2300	2300	2100	2100	1900	1900
240x70	10	6100	6100	5000	5000	4100	4000	3600	3400	3200	3100
	20	5500	5500	4600	4600	4100	4100	3700	3500	3300	3100
	40	4800	4800	4100	4100	3500	3500	3200	3100	2900	2900
	60	4400	4400	3700	3600	3200	3100	2800	2800	2600	2600
	90	4100	4000	3300	3200	2800	2800	2500	2500	2300	2300
280x70	10	6700	6700	5700	5700	4800	4800	4200	4100	3800	3600
	20	6100	6100	5200	5200	4600	4600	4200	4200	3800	3700
	40	5400	5400	4600	4500	4100	4100	3700	3600	3400	3300
	60	5000	5000	4200	4200	3700	3700	3300	3300	3000	3000
	90	4600	4500	3800	3800	3300	3200	2900	2900	2700	2700

## Verandah beam (single span) AS 4055 classification N1, N2 and N3 (Cont'd)

Roof load width (mm)		1500		3000		4500		6000		7500	
Rafter/truss spacing (mm)		600	1200	600	1200	600	1200	600	1200	600	1200
Member size DxB (mm)	Roof mass (kg/m <sup>2</sup> )	Maximum recommended Verandah beam span (mm)									
		Single span									
300x70	10	7000	7000	6000	6000	5200	5100	4500	4500	4000	3900
	20	6400	6400	5400	5400	4900	4800	4400	4400	4100	4000
	40	5700	5700	4800	4800	4300	4300	4000	3900	3600	3600
	60	5200	5200	4400	4400	4000	3900	3600	3500	3300	3200
	90	4800	4800	4000	4000	3500	3500	3200	3100	2900	2900
200x90	10	5600	5600	4800	4700	3900	3700	3400	3200	3000	2900
	20	5100	5100	4300	4300	3800	3700	3300	3300	3000	3000
	40	4500	4500	3700	3700	3200	3200	2900	2900	2600	2700
	60	4100	4100	3300	3300	2900	2900	2600	2600	2300	2300
	90	3700	3700	2900	2900	2500	2600	2300	2300	2100	2100
240x90	10	6300	6300	5400	5400	4700	4700	4100	4000	3700	3500
	20	5700	5700	4900	4900	4400	4400	4000	4000	3600	3600
	40	5100	5100	4300	4300	3800	3800	3400	3400	3100	3100
	60	4700	4700	4000	3900	3400	3400	3100	3100	2800	2800
	90	4300	4300	3500	3500	3000	3000	2700	2800	2500	2500
280x90	10	7000	6900	6000	6000	5400	5400	4800	4700	4300	4200
	20	6400	6400	5500	5500	4900	4900	4500	4500	4200	4200
	40	5700	5700	4800	4800	4300	4300	4000	4000	3700	3600
	60	5200	5300	4400	4400	4000	4000	3600	3600	3300	3300
	90	4800	4800	4100	4100	3600	3500	3200	3200	2900	2900
300x90	10	7300	7300	6300	6300	5600	5600	5100	5100	4600	4600
	20	6700	6700	5700	5700	5100	5200	4700	4700	4400	4400
	40	6000	5900	5100	5100	4600	4500	4200	4200	3900	3900
	60	5500	5500	4700	4700	4200	4200	3900	3800	3500	3500
	90	5100	5100	4300	4300	3800	3800	3500	3400	3200	3100
200x120	10	5800	5800	5000	5100	4500	4500	3900	3800	3600	3400
	20	5300	5300	4600	4600	4100	4100	3700	3600	3300	3300
	40	4700	4700	4000	4000	3500	3500	3100	3100	2900	2900
	60	4400	4400	3600	3600	3100	3100	2800	2800	2600	2600
	90	4000	4000	3200	3200	2800	2800	2500	2600	2300	2300
240x120	10	6600	6600	5700	5700	5100	5100	4600	4600	4200	4200
	20	6000	6000	5200	5200	4700	4600	4300	4300	4000	4000
	40	5400	5400	4600	4600	4100	4100	3800	3700	3400	3400
	60	5000	5000	4200	4200	3800	3700	3400	3300	3100	3100
	90	4600	4600	3900	3800	3400	3300	3000	3000	2800	2800
280x120	10	7200	7200	6300	6300	5700	5700	5200	5200	4800	4800
	20	6700	6700	5800	5800	5200	5200	4800	4800	4500	4400
	40	6000	6000	5100	5200	4600	4600	4300	4300	4000	4000
	60	5600	5600	4800	4700	4300	4300	4000	3900	3600	3600
	90	5100	5100	4400	4300	3900	3900	3500	3500	3300	3200
300x120	10	7500	7500	6600	6600	6000	6000	5500	5500	5100	5100
	20	7000	7000	6100	6100	5500	5500	5000	5000	4700	4700
	40	6300	6300	5400	5400	4900	4900	4500	4500	4200	4200
	60	5900	5800	5000	5000	4500	4500	4200	4200	3900	3900
	90	5400	5400	4600	4600	4100	4100	3800	3700	3500	3400
240x140	10	6700	6700	5800	5900	5300	5300	4800	4800	4500	4400
	20	6200	6200	5400	5400	4800	4800	4400	4400	4100	4100
	40	5600	5500	4800	4800	4300	4300	4000	3900	3600	3600
	60	5200	5200	4400	4400	4000	3900	3600	3500	3300	3200
	90	4800	4700	4000	4000	3500	3500	3200	3100	2900	2900
280x140	10	7400	7300	6500	6500	5900	5800	5400	5400	5000	5000
	20	6800	6800	6000	6000	5400	5400	5000	5000	4600	4600
	40	6200	6200	5300	5300	4800	4800	4400	4400	4100	4100
	60	5800	5700	4900	4900	4400	4400	4100	4100	3800	3800
	90	5300	5300	4500	4500	4100	4100	3700	3700	3400	3400
300x140	10	7700	7700	6800	6800	6100	6100	5600	5600	5200	5200
	20	7100	7200	6200	6300	5700	5600	5200	5200	4900	4800
	40	6500	6500	5600	5600	5000	5100	4700	4600	4400	4400
	60	6000	6000	5200	5200	4700	4600	4300	4300	4100	4000
	90	5600	5600	4800	4700	4300	4300	4000	4000	3700	3600

## Verandah beam (Continuous span) AS 4055 classification N1, N2 and N3

Roof load width (mm)		1500		3000		4500		6000		7500	
Rafter/truss spacing (mm)		600	1200	600	1200	600	1200	600	1200	600	1200
Member size DxB (mm)	Roof mass (kg/m <sup>2</sup> )	Maximum recommended Verandah beam span (mm)									
		Continuous span									
120x45	10	3000	3000	2100	2000	1700	1700	1500	1300	1400	NS
	20	3100	3100	2200	2100	1700	1700	1500	1400	1400	NS
	40	3000	3000	2100	2000	1700	1500	1500	1200	1300	NS
	60	2800	2800	2000	1900	1600	1500	1400	NS	NS	NS
	90	2500	2500	1800	1800	1500	1300	1300	NS	NS	NS
160x45	10	4000	4000	2800	2800	2300	2300	2000	1900	1600	1500
	20	4100	4100	2900	2900	2400	2400	2100	2000	1800	1600
	40	4100	4000	2800	2800	2300	2200	2000	1600	1700	1400
	60	3800	3700	2700	2700	2200	2100	1800	1600	1600	1200
	90	3300	3300	2500	2600	2000	1900	1600	1400	1500	NS
200x45	10	5000	5100	3600	3500	2900	2900	2600	2600	2300	1700
	20	5200	5200	3600	3600	3000	3000	2600	2700	2300	2100
	40	4900	5000	3600	3500	2900	2900	2500	2500	2200	1700
	60	4500	4500	3400	3300	2700	2700	2300	2100	1800	1600
	90	4100	4100	3100	3100	2500	2600	2200	1700	1600	1300
240x45	10	6100	6000	4300	4300	3500	3400	3000	3000	2800	2800
	20	6200	6200	4400	4400	3600	3500	3100	3100	2800	2800
	40	5600	5600	4300	4300	3500	3400	3000	3000	2600 <sub>5</sub>	2700 <sub>10</sub>
	60	5200	5200	4000	4000	3300	3200	2800	2800	2500 <sub>10</sub>	2500 <sub>10</sub>
	90	4700	4700	3800	3700	3000	3000	2600 <sub>5</sub>	2700 <sub>10</sub>	2100 <sub>10</sub>	1900
280x45	10	7100	7000	5000	5000	4100	4100	3600	3500	3200 <sub>10</sub>	3200 <sub>5</sub>
	20	7100	7200	5100	5200	4200	4200	3700 <sub>5</sub>	3600 <sub>5</sub>	3300 <sub>15</sub>	3200 <sub>10</sub>
	40	6300	6300	5000	5000	4000	4000	3500 <sub>10</sub>	3400 <sub>10</sub>	3100 <sub>20</sub>	3100 <sub>20</sub>
	60	5800	5800	4700	4700	3800	3800	3300 <sub>15</sub>	3200 <sub>15</sub>	2900 <sub>25</sub>	2900 <sub>25</sub>
	90	5300	5300	4400	4400	3600 <sub>10</sub>	3500 <sub>5</sub>	3000 <sub>20</sub>	3000 <sub>20</sub>	2500 <sub>25</sub>	2700 <sub>35</sub>
300x45	10	7600	7600	5400	5400	4400	4400	3800	3800	3500 <sub>15</sub>	3200 <sub>10</sub>
	20	7300	7500	5500	5500	4500	4500	3900 <sub>10</sub>	3900 <sub>10</sub>	3500 <sub>20</sub>	3200 <sub>15</sub>
	40	6500	6600	5300	5300	4300	4300	3700 <sub>15</sub>	3600 <sub>15</sub>	3300 <sub>25</sub>	3200 <sub>25</sub>
	60	6100	6100	5100	5100	4100 <sub>5</sub>	4100 <sub>10</sub>	3500 <sub>20</sub>	3200 <sub>15</sub>	3100 <sub>30</sub>	3100 <sub>30</sub>
	90	5500	5600	4700	4600	3800 <sub>15</sub>	3700 <sub>15</sub>	3200 <sub>30</sub>	3200 <sub>30</sub>	2600 <sub>30</sub>	2900 <sub>40</sub>
120x70	10	3500	3500	2500	2600	2000	2000	1700	1700	1600	1500
	20	3600	3500	2600	2600	2100	2000	1800	1800	1600	1500
	40	3500	3500	2500	2600	2000	1900	1700	1700	1500	1300
	60	3100	3100	2400	2500	1900	1900	1600	1600	1400	1200
	90	2800	2700	2200	2100	1700	1700	1500	1300	1400	1000
160x70	10	4700	4700	3400	3300	2800	2800	2400	2400	2100	2000
	20	4900	4900	3400	3400	2800	2800	2500	2600	2200	2100
	40	4500	4500	3400	3300	2700	2700	2300	2300	2100	2000
	60	4100	4100	3200	3100	2600	2600	2200	2100	1900	1900
	90	3700	3700	2900	2900	2300	2300	2000	2000	1800	1600
200x70	10	6000	5900	4200	4200	3500	3400	3000	3000	2700	2700
	20	6000	6000	4300	4300	3500	3400	3100	3000	2700	2800
	40	5300	5300	4200	4200	3400	3300	2900	2900	2600	2600
	60	4800	4900	4000	3900	3200	3200	2800	2800	2400	2400
	90	4400	4400	3600	3600	3000	3000	2600	2600	2300	2100
240x70	10	7200	7200	5100	5100	4100	4100	3600	3500	3300	3200
	20	6700	6800	5200	5200	4200	4200	3700	3600	3300	3200
	40	6000	6000	5000	5100	4100	4100	3500	3400	3100	3100
	60	5500	5600	4700	4700	3900	3800	3300	3200	2900	2900
	90	5100	5100	4300	4200	3600	3500	3100	3100	2700	2800
280x70	10	8000	8400	5900	5900	4800	4800	4200	4200	3800	3700
	20	7400	7600	6100	6000	5000	5000	4300	4300	3900	3800
	40	6700	6700	5700	5700	4800	4700	4100	4100	3600	3500
	60	6200	6200	5200	5200	4500	4500	3900	3800	3400	3400
	90	5700	5700	4800	4800	4200	4200	3600	3500	3200 <sub>5</sub>	3200 <sub>5</sub>
300x70	10	8300	8800	6400	6300	5200	5200	4500	4500	4100	4100
	20	7700	8000	6500	6500	5300	5300	4600	4600	4100	4100
	40	6900	7000	6000	6000	5100	5100	4400	4400	3900	3800
	60	6500	6500	5500	5500	4800	4800	4100	4100	3700 <sub>5</sub>	3600 <sub>5</sub>
	90	6000	6000	5000	5100	4500	4400	3900 <sub>5</sub>	3800	3400 <sub>10</sub>	3300 <sub>10</sub>
200x90	10	6800	6800	4800	4800	3900	3900	3400	3300	3100	3000
	20	6300	6300	4900	4900	4000	4000	3500	3400	3100	3100
	40	5600	5600	4700	4700	3900	3800	3300	3200	2900	2900
	60	5100	5100	4300	4300	3600	3600	3100	3100	2800	2800
	90	4700	4700	4000	3900	3400	3300	2900	2900	2600	2600

## Verandah beam (Continuous span) AS 4055 classification N1, N2 and N3 (Cont'd)

Roof load width (mm)		1500		3000		4500		6000		7500	
Rafter/truss spacing (mm)		600	1200	600	1200	600	1200	600	1200	600	1200
Member size DxB (mm)	Roof mass (kg/m <sup>2</sup> )	Maximum recommended Verandah beam span (mm)									
		Continuous span									
240x90	10	7600	7900	5800	5700	4700	4700	4100	4100	3700	3600
	20	7000	7200	5900	5800	4800	4800	4200	4200	3700	3700
	40	6300	6300	5400	5400	4600	4600	4000	4000	3500	3400
	60	5900	5900	4900	5000	4400	4300	3800	3700	3300	3300
	90	5400	5400	4500	4500	4000	4000	3500	3400	3100	3100
280x90	10	8300	8700	6700	6700	5500	5500	4800	4700	4300	4300
	20	7600	8000	6700	6800	5600	5600	4900	4900	4400	4400
	40	6900	7100	6000	6000	5400	5400	4600	4600	4100	4100
	60	6500	6500	5600	5600	5000	5000	4400	4400	3900	3800
300x90	90	6000	6000	5100	5100	4600	4600	4100	4100	3600	3500
	10	8600	9100	7200	7200	5900	5900	5100	5200	4600	4600
	20	7900	8400	7000	7100	6000	6000	5300	5300	4700	4600
	40	7200	7400	6300	6300	5700	5700	4900	4900	4400	4400
	60	6800	6900	5800	5900	5200	5300	4700	4600	4200	4200
90	6300	6300	5300	5300	4800	4800	4400	4400	3900	3800	
200x120	10	7100	7300	5500	5500	4500	4500	4000	3900	3500	3500
	20	6600	6700	5700	5600	4700	4600	4000	4000	3600	3500
	40	5900	5900	5000	5100	4400	4400	3800	3700	3400	3300
	60	5500	5500	4600	4600	4200	4200	3600	3500	3200	3200
	90	5000	5100	4200	4200	3800	3700	3400	3300	3000	3000
240x120	10	7900	8200	6700	6700	5500	5400	4700	4700	4300	4300
	20	7300	7500	6400	6500	5600	5600	4800	4800	4300	4300
	40	6700	6700	5800	5800	5200	5200	4600	4500	4100	4000
	60	6200	6200	5300	5300	4800	4800	4300	4300	3900	3800
280x120	90	5700	5700	4900	4900	4400	4300	4000	4000	3600	3500
	10	8600	9000	7600	7800	6400	6400	5500	5500	5000	5000
	20	8000	8400	7100	7200	6500	6500	5700	5600	5000	5100
	40	7300	7500	6400	6400	5800	5800	5300	5300	4700	4700
300x120	60	6900	7000	5900	5900	5300	5300	4900	5000	4500	4400
	90	6400	6400	5400	5500	4900	4900	4500	4500	4200	4200
	10	8900	9400	8000	8300	6800	6800	6000	5900	5300	5300
	20	8300	8700	7300	7500	6700	6800	6100	6000	5400	5400
	40	7600	7800	6700	6700	6100	6100	5600	5600	5100	5100
60	7100	7300	6200	6200	5600	5700	5200	5200	4800	4800	
90	6700	6700	5700	5700	5200	5200	4800	4800	4500	4400	
240x140	10	8100	8300	7100	7200	5900	5900	5100	5200	4600	4600
	20	7500	7700	6600	6700	6000	6000	5200	5300	4700	4600
	40	6800	6900	5900	5900	5400	5400	4900	4900	4400	4400
	60	6400	6400	5500	5500	4900	5000	4600	4600	4100	4100
	90	5900	5900	5000	5100	4500	4500	4200	4200	3900	3800
280x140	10	8700	9200	7800	8100	6900	6900	6000	6000	5400	5400
	20	8200	8500	7200	7400	6600	6700	6100	6100	5400	5400
	40	7400	7700	6600	6600	6000	6000	5500	5600	5100	5100
	60	7000	7200	6100	6100	5500	5600	5100	5100	4800	4800
300x140	90	6500	6600	5600	5700	5100	5100	4700	4700	4400	4400
	10	9100	9600	8100	8500	7400	7400	6400	6400	5800	5700
	20	8500	8900	7500	7800	6900	7000	6400	6500	5800	5800
	40	7700	8100	6900	7000	6300	6300	5800	5800	5500	5500
	60	7300	7500	6400	6400	5800	5900	5400	5400	5100	5100
90	6900	7000	5900	5900	5400	5400	5000	5000	4700	4700	

### NOTES:

- D = member depth, B = member breadth, NS = not suitable.
- End bearing lengths = 70 mm at end supports and 70 mm at internal supports for continuous members. Subscript values indicate the minimum additional bearing length where required to be greater than 70 mm at end supports and 70 mm at internal supports.
- Restraint value for slenderness calculations is 1200 mm
- Not all sizes of SmartLam GLT15S in this table are stocked in each state. Please check with your supplier before ordering
- Table does not list all available SmartLam GLT15S sizes. See page 11 for full list of sizes

## Verandah beam (single span) AS 4055 classification C1, C2 and C3

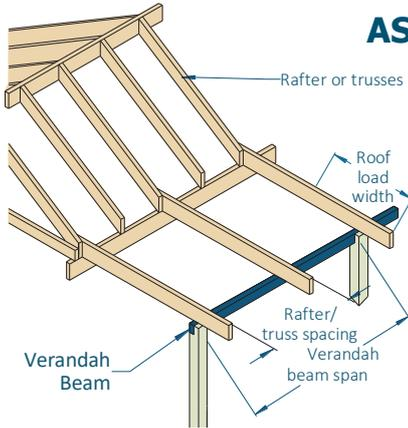

### EXAMPLE:

wind speed = C3  
 sheet roof - 40 kg/m<sup>2</sup>  
 rafter/truss spacing = 600 mm  
 verandah span = 3500 mm (single span)  
 roof load width = 3900 mm

Enter span table at 4500 roof load width column, rafter spacing of 600 mm, and read down to a span equal to or greater than 3500 mm at 40 kg/m<sup>2</sup> row

### ADOPT:

**SmartLam GLT15S - 300 x 70**

Roof load width (mm)		1500		3000		4500		6000		7500	
Rafter/truss spacing (mm)		600	1200	600	1200	600	1200	600	1200	600	1200
Member size DxB (mm)	Roof mass (kg/m <sup>2</sup> )	Maximum recommended Verandah span (mm)									
		Single span									
120x45	10	1900	1700	1300	NS	NS	NS	NS	NS	NS	NS
	20	1900	1700	1300	NS	NS	NS	NS	NS	NS	NS
	40	2000	1800	1400	NS	1000	NS	NS	NS	NS	NS
	60	2000	1900	1400	NS	1100	NS	NS	NS	NS	NS
	90	1800	1800	1400	NS	1000	NS	NS	NS	NS	NS
160x45	10	2600	2600	1800	1500	1400	NS	1000	NS	NS	NS
	20	2600	2600	1800	1500	1500	NS	1000	NS	NS	NS
	40	2700	2600	1800	1600	1500	NS	1300	NS	NS	NS
	60	2700	2700	1900	1700	1500	NS	1300	NS	NS	NS
	90	2500	2500	1800	1600	1500	NS	1100	NS	NS	NS
200x45	10	3300	3100	2300	2200	1800	1400	1600	NS	1100	NS
	20	3300	3200	2400	2200	1800	1500	1600	NS	1200	NS
	40	3400	3200	2400	2300	1900	1600	1600	NS	1400	NS
	60	3500	3300	2500	2300	1900	1600	1600	NS	1500	NS
	90	3100	3100	2400	2300	1900	1500	1600	NS	1200	NS
240x45	10	4000	3800	2800	2700	2300	1800	1900	1300	1700	NS
	20	4000	3900	2800	2700	2300	1900	1900	1400	1700	NS
	40	4100	4000	2900	2800	2400	2200	2000	1500	1700	NS
	60	4100	4100	2900	2800	2400	2300	2000	1600	1800	1000
	90	3700	3700	2900	2800	2300	2200	2000	1500	1700	NS
280x45	10	4700	4600	3300	3100	2700	2600	2300	1700	2000	1300
	20	4700	4700	3300	3200	2700	2600	2300	1800	2000	1400
	40	4800	4800	3400	3200	2700	2700	2400	1800	2000	1500
	60	4600	4600	3500	3300	2800	2700	2400	1900	2100	1600 <sub>5</sub>
	90	4200	4200	3400	3200	2700	2700	2300	1800	2000	1400
300x45	10	5000	5000	3500	3400	2800	2800	2500	1900	2100	1600
	20	5100	5000	3600	3400	2900	2800	2500	1900	2200	1700
	40	5200	5100	3600	3500	2900	2800	2600	2000	2300	1700
	60	4900	4900	3700	3500	3000	2900	2600	2500 <sub>5</sub>	2300	1700
	90	4400	4400	3600	3500	2900	2800	2500	2000	2200	1600 <sub>15</sub>
120x70	10	2300	2200	1500	1100	1300	NS	1100	NS	NS	NS
	20	2300	2200	1600	1200	1300	NS	1100	NS	NS	NS
	40	2400	2300	1600	1200	1300	NS	1100	NS	NS	NS
	60	2300	2300	1600	1300	1300	NS	1100	NS	1000	NS
	90	2000	2000	1600	1200	1300	NS	1100	NS	NS	NS
160x70	10	3100	3000	2200	2100	1700	1400	1500	1000	1300	NS
	20	3100	3000	2200	2100	1700	1400	1500	1000	1300	NS
	40	3200	3100	2300	2100	1800	1500	1500	1100	1400	NS
	60	3100	3100	2300	2200	1800	1500	1500	1100	1400	NS
	90	2700	2800	2100	2100	1700	1500	1500	1100	1300	NS
200x70	10	3900	3800	2700	2700	2200	2100	1900	1600	1700	1200
	20	3900	3800	2800	2700	2300	2100	1900	1700	1700	1300
	40	4000	3900	2800	2700	2300	2200	1900	1700	1700	1400
	60	3900	3800	2900	2800	2400	2200	2000	1800	1800	1500
	90	3400	3400	2700	2700	2300	2200	1900	1700	1700	1300
240x70	10	4700	4700	3300	3200	2700	2600	2300	2200	2000	1700
	20	4800	4700	3300	3200	2700	2600	2400	2300	2100	1800
	40	4800	4800	3400	3300	2800	2700	2400	2300	2100	1800
	60	4400	4400	3500	3300	2800	2700	2500	2400	2200	2100
	90	4100	4000	3300	3200	2700	2700	2400	2300	2100	1800
280x70	10	5500	5400	3900	3700	3100	3000	2700	2700	2500	2400
	20	5600	5500	3900	3800	3200	3000	2700	2700	2500	2400
	40	5400	5400	4000	3900	3300	3100	2800	2700	2500	2400
	60	5000	5000	4100	4000	3300	3200	2900	2800	2600	2500
	90	4600	4500	3800	3800	3200	3100	2800	2700	2500	2400

## Verandah beam (Single span) AS 4055 classification C1, C2 and C3 (Cont'd)

Roof load width (mm)		1500		3000		4500		6000		7500	
Rafter/truss spacing (mm)		600	1200	600	1200	600	1200	600	1200	600	1200
Member size DxB (mm)	Roof mass (kg/m <sup>2</sup> )	Maximum recommended Verandah beam span (mm)									
		Single span									
300x70	10	5900	5800	4100	4000	3400	3200	2900	2800	2600	2500
	20	6000	5900	4200	4100	3400	3300	2900	2800	2600	2600
	40	5700	5700	4300	4200	3500	3300	3000	2900	2700	2600
	60	5200	5200	4400	4300	3600	3400	3100	3000	2700	2700
	90	4800	4800	4000	4000	3500	3300	3000	2900	2600	2600
240x90	10	5400	5300	3800	3600	3000	2900	2600	2600	2400	2300
	20	5400	5300	3800	3600	3100	3000	2700	2600	2400	2300
	40	5100	5100	3900	3700	3200	3000	2700	2700	2500	2300
	60	4700	4700	4000	3800	3200	3100	2800	2700	2500	2400
	90	4300	4300	3500	3500	3000	3000	2700	2600	2400	2300
280x90	10	6300	6200	4400	4300	3600	3400	3100	3000	2800	2700
	20	6300	6200	4400	4400	3600	3500	3100	3000	2800	2700
	40	5700	5700	4500	4500	3700	3500	3200	3100	2800	2800
	60	5200	5300	4400	4400	3800	3600	3300	3100	2900	2800
	90	4800	4800	4100	4100	3600	3500	3100	3000	2800	2700
300x90	10	6700	6700	4700	4700	3900	3700	3300	3200	3000	2900
	20	6700	6700	4800	4700	3900	3700	3400	3200	3000	2900
	40	6000	5900	4900	4800	4000	3800	3500	3300	3100	2900
	60	5500	5500	4700	4700	4100	3900	3500	3400	3100	3000
	90	5100	5100	4300	4300	3800	3800	3400	3200	3000	2900
200x120	10	5200	5100	3600	3500	2900	2800	2500	2500	2300	2200
	20	5200	5200	3700	3500	3000	2900	2600	2500	2300	2200
	40	4700	4700	3800	3600	3000	2900	2600	2600	2400	2200
	60	4400	4400	3600	3600	3100	3000	2700	2600	2400	2300
	90	4000	4000	3200	3200	2800	2800	2500	2500	2300	2200
240x120	10	6100	6100	4400	4300	3600	3400	3100	2900	2700	2700
	20	6000	6000	4400	4300	3600	3400	3100	3000	2800	2700
	40	5400	5400	4500	4500	3700	3500	3200	3000	2800	2700
	60	5000	5000	4200	4200	3800	3600	3200	3100	2900	2800
	90	4600	4600	3900	3800	3400	3300	3000	3000	2800	2700
280x120	10	6900	6900	5100	5100	4200	4000	3600	3400	3200	3100
	20	6700	6700	5200	5100	4200	4100	3700	3500	3300	3100
	40	6000	6000	5100	5200	4300	4200	3700	3600	3300	3200
	60	5600	5600	4800	4700	4300	4300	3800	3600	3400	3200
	90	5100	5100	4400	4300	3900	3900	3500	3500	3200	3100
300x120	10	7300	7300	5500	5400	4500	4400	3900	3700	3500	3300
	20	7000	7000	5500	5400	4500	4500	3900	3800	3500	3300
	40	6300	6300	5400	5400	4600	4600	4000	3800	3600	3400
	60	5800	5800	5000	5000	4500	4500	4100	3900	3600	3500
	90	5400	5400	4600	4600	4100	4100	3800	3700	3500	3300
240x140	10	6400	6400	4700	4700	3800	3700	3300	3200	3000	2900
	20	6200	6200	4800	4700	3900	3700	3400	3200	3000	2900
	40	5600	5500	4800	4800	4000	3800	3400	3300	3100	2900
	60	5200	5200	4400	4400	4000	3900	3500	3300	3100	3000
	90	4800	4700	4000	4000	3500	3500	3200	3100	2900	2900
280x140	10	7200	7200	5500	5400	4500	4500	3900	3700	3500	3300
	20	6800	6800	5600	5500	4600	4500	3900	3800	3500	3400
	40	6200	6200	5300	5300	4700	4600	4000	3900	3600	3400
	60	5700	5700	4900	4900	4400	4400	4100	4000	3700	3500
	90	5300	5300	4500	4500	4100	4100	3700	3700	3400	3300
300x140	10	7500	7600	5900	5800	4800	4800	4200	4100	3800	3600
	20	7100	7200	6000	5900	4900	4800	4200	4100	3800	3600
	40	6500	6500	5600	5600	5000	4900	4300	4200	3900	3700
	60	6000	6000	5200	5200	4700	4600	4300	4300	3900	3800
	90	5600	5600	4800	4700	4300	4300	4000	4000	3700	3600

## Verandah beam (Continuous span) AS 4055 classification C1, C2 and C3

Roof load width (mm)		1500		3000		4500		6000		7500	
Rafter/truss spacing (mm)		600	1200	600	1200	600	1200	600	1200	600	1200
Member size DxB (mm)	Roof mass (kg/m <sup>2</sup> )	Maximum recommended Verandah beam span (mm)									
		Continuous span									
120x45	10	2000	1900	1400	NS	NS	NS	NS	NS	NS	NS
	20	2000	1900	1400	NS	NS	NS	NS	NS	NS	NS
	40	2000	2000	1400	1200	NS	NS	NS	NS	NS	NS
	60	2100	2000	1500	1200	1200	NS	NS	NS	NS	NS
	90	2000	2000	1400	1200	NS	NS	NS	NS	NS	NS
160x45	10	2700	2700	1800	1600	1500	NS	1000	NS	1000	NS
	20	2700	2700	1900	1600	1500	NS	1000	NS	1000	NS
	40	2700	2800	1900	1600	1500	NS	1000	NS	1000	NS
	60	2800	2800	2000	1600	1600	1200	1000	NS	1000	NS
	90	2800	2800	1900	1600	1500	NS	1000	NS	1000	NS
200x45	10	3300	3300	2300	2100	1600	1300	1300	NS	1100	NS
	20	3400	3300	2300	2100	1600	1400	1400	NS	1100	NS
	40	3400	3400	2400	2400	1700	1400	1400	NS	1100	NS
	60	3500	3400	2500	2500	1700	1500	1500	1000	1100	NS
	90	3400	3400	2400	2400	1700	1400	1400 <sub>5</sub>	NS	1100	NS
240x45	10	4000	4000	2800	2800	2000	1600	1600	1200	1300	NS
	20	4000	4000	2800	2800	2000	1600	1600	1200	1300	NS
	40	4100	4100	2900	2900	2200	1900	1900 <sub>10</sub>	1900 <sub>10</sub>	1800 <sub>30</sub>	NS
	60	4200	4200	3000	3000	2400 <sub>10</sub>	2400 <sub>10</sub>	1900 <sub>15</sub>	1900 <sub>15</sub>	1800 <sub>40</sub>	NS
	90	4100	4100	2900	2900	2200 <sub>10</sub>	1900	1900 <sub>25</sub>	1800 <sub>20</sub>	1800 <sub>40</sub>	NS
280x45	10	4700	4600	3300	3200	2500	2700 <sub>10</sub>	2000 <sub>5</sub>	2000 <sub>5</sub>	2000 <sub>25</sub>	1700 <sub>15</sub>
	20	4700	4700	3300	3200	2500 <sub>5</sub>	2700 <sub>10</sub>	2000 <sub>10</sub>	2000 <sub>10</sub>	2000 <sub>30</sub>	1700 <sub>20</sub>
	40	4800	4800	3400	3200	2600 <sub>10</sub>	2800 <sub>20</sub>	2000 <sub>15</sub>	2000 <sub>15</sub>	2000 <sub>40</sub>	1900 <sub>30</sub>
	60	4900	4900	3500 <sub>5</sub>	3400 <sub>5</sub>	2600 <sub>15</sub>	2800 <sub>30</sub>	2000 <sub>20</sub>	2000 <sub>20</sub>	2000 <sub>45</sub>	1900 <sub>45</sub>
	90	4800	4800	3400 <sub>10</sub>	3200 <sub>5</sub>	2600 <sub>25</sub>	2800 <sub>35</sub>	2000 <sub>30</sub>	2000 <sub>30</sub>	2000 <sub>55</sub>	1700 <sub>40</sub>
300x45	10	5000	5000	3600	3200	2600 <sub>5</sub>	2900 <sub>10</sub>	2500 <sub>5</sub>	2000 <sub>10</sub>	2100 <sub>30</sub>	1200
	20	5100	5100	3600	3300	2600 <sub>10</sub>	2900 <sub>15</sub>	2000 <sub>10</sub>	2000 <sub>10</sub>	2000 <sub>35</sub>	1900 <sub>25</sub>
	40	5200	5200	3600 <sub>5</sub>	3600 <sub>5</sub>	2900 <sub>20</sub>	2900 <sub>25</sub>	2100 <sub>20</sub>	2000 <sub>20</sub>	2000 <sub>40</sub>	2000 <sub>40</sub>
	60	5300	5300	3700 <sub>10</sub>	3700 <sub>10</sub>	3000 <sub>30</sub>	3000 <sub>30</sub>	2300 <sub>35</sub>	2000 <sub>25</sub>	2000 <sub>50</sub>	2000 <sub>45</sub>
	90	5200	5200	3600 <sub>15</sub>	3600 <sub>15</sub>	2800 <sub>30</sub>	2900 <sub>40</sub>	2000 <sub>35</sub>	2000 <sub>35</sub>	2000 <sub>65</sub>	1900 <sub>55</sub>
120x70	10	2300	2300	1600	1500	1300	1000	NS	NS	NS	NS
	20	2300	2500	1600	1600	1400	1000	NS	NS	NS	NS
	40	2400	2500	1700	1600	1400	1000	1000	NS	NS	NS
	60	2500	2600	1700	1700	1400	1000	1100	NS	NS	NS
	90	2400	2600	1700	1600	1400	1000	NS	NS	NS	NS
160x70	10	3100	3100	2200	2100	1800	1600	1500	1300	1400	NS
	20	3200	3100	2200	2100	1800	1600	1600	1300	1400	NS
	40	3200	3200	2200	2200	1800	1600	1600	1300	1400	NS
	60	3300	3200	2300	2300	1900	1900	1600	1400	1500	NS
	90	3200	3200	2200	2200	1800	1600	1600	1300	1400	NS
200x70	10	3900	3900	2800	2800	2200	2100	1900	1600	1600	1300
	20	4000	4000	2800	2800	2300	2200	2000	1600	1600	1300
	40	4000	4000	2800	2900	2300	2200	2000	1700	1600	1300
	60	4100	4100	2900	2900	2400	2400	2100	1700	1700	1400
	90	4000	4000	2800	2800	2300	2200	2000	1600	1600	1300
240x70	10	4700	4700	3300	3300	2700	2700	2300	1900	1900	1900
	20	4800	4700	3400	3300	2700	2800	2400	1900	1900	1900
	40	4900	4900	3500	3400	2800	2800	2400	2400	2100 <sub>5</sub>	1900
	60	5000	5000	3500	3400	2900	2900	2500	2500	2200 <sub>10</sub>	2100 <sub>10</sub>
	90	4800	4800	3400	3300	2800	2800	2400 <sub>5</sub>	1900	1900 <sub>5</sub>	1900 <sub>5</sub>
280x70	10	5500	5500	3900	3900	3200	3200	2800	2800	2400 <sub>5</sub>	2000
	20	5600	5600	3900	3900	3200	3200	2800	2800	2500 <sub>10</sub>	2500 <sub>10</sub>
	40	5700	5700	4000	4000	3300	3200	2800 <sub>5</sub>	2800 <sub>10</sub>	2500 <sub>15</sub>	2500 <sub>15</sub>
	60	5800	5800	4100	4100	3400	3300	2900 <sub>15</sub>	2900 <sub>15</sub>	2600 <sub>25</sub>	2700 <sub>30</sub>
	90	5700	5600	4000	4000	3300 <sub>5</sub>	3200 <sub>5</sub>	2800 <sub>20</sub>	2800 <sub>20</sub>	2500 <sub>30</sub>	2500 <sub>30</sub>
300x70	10	5900	5900	4200	4200	3400	3300	2900	2900 <sub>5</sub>	2500 <sub>10</sub>	2500 <sub>5</sub>
	20	6000	5900	4200	4200	3500	3400	3000 <sub>5</sub>	3000 <sub>5</sub>	2600 <sub>15</sub>	2700 <sub>15</sub>
	40	6100	6100	4300	4300	3500	3400	3000 <sub>10</sub>	3000 <sub>10</sub>	2700 <sub>20</sub>	2800 <sub>25</sub>
	60	6200	6200	4400	4400	3600 <sub>5</sub>	3500 <sub>5</sub>	3100 <sub>20</sub>	3100 <sub>20</sub>	2800 <sub>30</sub>	2800 <sub>35</sub>
	90	6000	6000	4300	4300	3500 <sub>10</sub>	3400 <sub>10</sub>	3000 <sub>25</sub>	3000 <sub>25</sub>	2600 <sub>35</sub>	2700 <sub>40</sub>
200x90	10	4500	4400	3200	3100	2600	2600	2200	2100	2000	1600
	20	4500	4500	3200	3100	2600	2700	2200	2100	2000	1700
	40	4600	4600	3300	3200	2600	2700	2300	2200	2000	1700
	60	4700	4700	3300	3300	2700	2700	2300	2200	2100	1700
	90	4600	4500	3200	3200	2600	2700	2200	2100	2000	1700

## Verandah beam (continuous span) AS 4055 classification C1, C2 and C3 (Cont'd)

Roof load width (mm)		1500		3000		4500		6000		7500	
Rafter/truss spacing (mm)		600	1200	600	1200	600	1200	600	1200	600	1200
Member size DxB (mm)	Roof mass (kg/m <sup>2</sup> )	Maximum recommended Verandah beam span (mm)									
		Continuous span									
300x70	10	5900	5900	4200	4200	3400	3300	2900	2900 <sub>5</sub>	2500 <sub>10</sub>	2500 <sub>5</sub>
	20	6000	5900	4200	4200	3500	3400	3000 <sub>5</sub>	3000 <sub>5</sub>	2600 <sub>15</sub>	2700 <sub>15</sub>
	40	6100	6100	4300	4300	3500	3400	3000 <sub>10</sub>	3000 <sub>10</sub>	2700 <sub>20</sub>	2800 <sub>25</sub>
	60	6200	6200	4400	4400	3600 <sub>5</sub>	3500 <sub>5</sub>	3100 <sub>20</sub>	3100 <sub>20</sub>	2800 <sub>30</sub>	2800 <sub>35</sub>
	90	6000	6000	4300	4300	3500 <sub>10</sub>	3400 <sub>10</sub>	3000 <sub>25</sub>	3000 <sub>25</sub>	2600 <sub>35</sub>	2700 <sub>40</sub>
200x90	10	4500	4400	3200	3100	2600	2600	2200	2100	2000	1600
	20	4500	4500	3200	3100	2600	2700	2200	2100	2000	1700
	40	4600	4600	3300	3200	2600	2700	2300	2200	2000	1700
	60	4700	4700	3300	3300	2700	2700	2300	2200	2100	1700
	90	4600	4500	3200	3200	2600	2700	2200	2100	2000	1700
240x90	10	5400	5400	3800	3700	3100	3100	2700	2700	2400	1900
	20	5400	5400	3800	3800	3100	3100	2700	2700	2400	2400
	40	5500	5500	3900	3900	3200	3200	2800	2800	2500	2500
	60	5700	5600	4000	4000	3300	3200	2800	2800	2500	2500
	90	5400	5400	3900	3800	3200	3100	2700	2700	2400 <sub>5</sub>	2400 <sub>5</sub>
280x90	10	6300	6300	4400	4400	3600	3500	3100	3100	2800	2800
	20	6400	6300	4500	4400	3600	3600	3200	3200	2800	2800
	40	6500	6500	4600	4500	3700	3600	3200	3200	2900 <sub>5</sub>	2900 <sub>5</sub>
	60	6500	6500	4700	4600	3800	3700	3300 <sub>5</sub>	3200 <sub>5</sub>	2900 <sub>15</sub>	2900 <sub>15</sub>
	90	6000	6000	4500	4500	3700	3600	3200 <sub>5</sub>	3200 <sub>5</sub>	2800 <sub>15</sub>	2800 <sub>20</sub>
300x90	10	6700	6700	4800	4700	3900	3800	3400	3300	3000	3000
	20	6800	6800	4800	4700	3900	3900	3400	3300	3000 <sub>5</sub>	3000 <sub>5</sub>
	40	7000	6900	4900	4900	4000	4000	3500	3400	3100 <sub>10</sub>	3100 <sub>10</sub>
	60	6800	6900	5000	5000	4100	4100	3600 <sub>10</sub>	3500 <sub>10</sub>	3200 <sub>20</sub>	3200 <sub>20</sub>
	90	6300	6300	4800	4800	4000	3900	3400 <sub>15</sub>	3300 <sub>10</sub>	3000 <sub>25</sub>	3000 <sub>25</sub>
240x120	10	6200	6200	4400	4400	3600	3500	3100	3100	2800	2800
	20	6300	6300	4400	4400	3600	3500	3100	3100	2800	2800
	40	6400	6400	4500	4500	3700	3600	3200	3200	2800	2900
	60	6200	6200	4600	4600	3800	3700	3300	3200	2900	2900
	90	5700	5700	4500	4400	3600	3600	3100	3100	2800	2800
280x120	10	7300	7300	5100	5200	4200	4200	3600	3500	3300	3200
	20	7400	7400	5200	5200	4200	4200	3700	3600	3300	3200
	40	7300	7500	5300	5300	4300	4300	3700	3700	3400	3300
	60	6800	6900	5400	5400	4400	4400	3800	3800	3400	3300
	90	6400	6400	5200	5200	4200	4200	3700	3600	3300 <sub>5</sub>	3200 <sub>5</sub>
300x120	10	7800	7800	5500	5500	4500	4400	3900	3800	3500	3400
	20	7900	7900	5500	5500	4500	4500	3900	3900	3500	3400
	40	7600	7800	5700	5600	4600	4600	4000	4000	3600	3500
	60	7100	7300	5800	5700	4700	4700	4100	4100	3700 <sub>10</sub>	3600 <sub>5</sub>
	90	6700	6700	5600	5600	4600	4500	3900	3900	3500 <sub>10</sub>	3400 <sub>10</sub>
240x140	10	6700	6700	4700	4700	3900	3800	3400	3300	3000	3000
	20	6800	6800	4800	4800	3900	3900	3400	3300	3000	3000
	40	6800	6900	4900	4900	4000	4000	3500	3400	3100	3100
	60	6400	6400	5000	5100	4100	4100	3500	3500	3200	3100
	90	5900	5900	4800	4800	3900	3900	3400	3300	3000	3000
280x140	10	7900	7900	5500	5500	4500	4500	3900	3900	3500	3400
	20	8000	8000	5600	5600	4600	4500	4000	4000	3500	3500
	40	7500	7700	5700	5700	4700	4600	4000	4000	3600	3500
	60	7000	7200	5900	5800	4800	4700	4100	4100	3700	3600
	90	6500	6600	5600	5600	4600	4500	4000	4000	3500	3400
300x140	10	8500	8400	6000	5900	4800	4800	4200	4200	3800	3700
	20	8500	8500	6000	6000	4900	4900	4200	4200	3800	3700
	40	7800	8100	6100	6100	5000	5000	4300	4300	3900	3800
	60	7300	7500	6300	6200	5100	5200	4400	4400	4000	3900
	90	6900	7000	5900	5900	4900	4900	4200	4200	3800 <sub>5</sub>	3700 <sub>5</sub>

### NOTES:

- D = member depth, B = member breadth, NS = not suitable.
- End bearing lengths = 70mm at end supports and 70 mm at internal supports for continuous members. Subscript values indicate the minimum additional bearing length where required to be greater than 70 mm at end supports and 70 mm at internal supports.
- Restraint value for slenderness calculations is 1200 mm
- Not all sizes of SmartLam GLT15S in this table are stocked in each state. Please check with your supplier before ordering
- Table does not list all available SmartLam GLT15S sizes. See page 11 for full list of sizes

## Hip rafter - sheet and tile roof AS 4055 wind classification N1, N2, N3, C1, C2 & C3

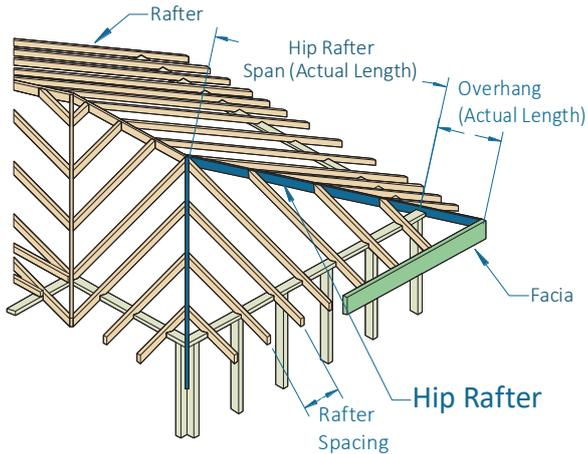

### EXAMPLE:

wind speed = N3  
 roof load = 40 kg/m<sup>2</sup> (sheet roof)  
 hip rafter span = 4500 mm (single span)  
 rafter spacing = 600 mm

Enter column at (N1,N2 & N3) wind speed, 600 mm rafter spacing and read down to span equal to or greater than 4500 mm for a 40 kg/m<sup>2</sup> roof load

### ADOPT:

SmartLam GLT15S — 240 x 45

Wind Speed		N1, N2 & N3				C1, C2 & C3			
Rafter spacing (mm)		600		1200		600		1200	
		Maximum Rafter span + overhang span (mm)				Maximum Rafter span + overhang span (mm)			
Member size DxB (mm)	Roof & ceiling mass (kg/m <sup>2</sup> )	Span	Overhang	Span	Overhang	Span	Overhang	Span	Overhang
		Single span				Single span			
120x45	40	2900	250	2900	250	2600	250	2600	250
	90	2400	250	2400	250	2400	250	2400	250
160x45	40	3600	300	3600	300	3200	300	3200	300
	90	3000	300	3000	300	3000	300	3000	300
200x45	40	4200	450	4200	450	3700	450	3700	450
	90	3600	450	3600	450	3600	450	3600	450
240x45	40	4800	650	4800	650	4200	650	4200	650
	90	4100	650	4100	600	4100	650	4100	600
280x45	40	5400	850	5400	850	4600	850	4600	850
	90	4600	800	4600	800	4600	800	4600	800
300x45	40	5700	950	5700	950	4800	950	4900	950
	90	4800	900	4800	900	4800 <sub>5</sub>	900	4800 <sub>5</sub>	900
320x45	40	6000	1000	6000	1000	5000	1000	5100 <sub>5</sub>	1000
	90	5100	1000	5100	950	5000 <sub>10</sub>	1000	5000 <sub>10</sub>	950
360x45	40	6400	1150	6400	1150	5500 <sub>10</sub>	1150	5500 <sub>10</sub>	1150
	90	5500	1050	5500	1050	5400 <sub>15</sub>	1050	5400 <sub>15</sub>	1050
120x70	40	3100	350	3100	350	2900	350	2900	350
	90	2600	350	2600	300	2600	350	2600	300
160x70	40	3900	600	3900	550	3500	600	3500	550
	90	3300	550	3300	550	3300	550	3300	550
200x70	40	4600	850	4600	800	4100	850	4100	800
	90	3800	800	3800	750	3800	800	3800	750
240x70	40	5200	1000	5200	1000	4700	1000	4700	1000
	90	4400	1000	4400	1000	4400	1000	4400	1000
280x70	40	5800	1250	5800	1250	5200	1250	5200	1250
	90	4900	1150	4900	1150	4900	1150	4900	1150
300x70	40	6100	1400	6100	1350	5400	1400	5400	1350
	90	5200	1250	5200	1250	5200	1250	5200	1250
320x70	40	6300	1500	6300	1500	5700	1500	5600	1500
	90	5400	1350	5400	1350	5400	1350	5400	1350
360x70	40	6700	1750	6800	1700	6100	1700	6100	1700
	90	5900	1550	5900	1550	5900 <sub>5</sub>	1550	5900 <sub>5</sub>	1550
200x90	40	4800	1000	4800	1000	4500	1000	4500	1000
	90	4100	1000	4100	1000	4100	1000	4100	1000
240x90	40	5500	1300	5500	1300	5100	1300	5100	1300
	90	4700	1200	4700	1200	4700	1200	4700	1200
280x90	40	6100	1550	6100	1550	5600	1550	5600	1550
	90	5200	1400	5200	1400	5200	1400	5200	1400
300x90	40	6400	1700	6300	1700	5900	1700	5900	1700
	90	5500	1550	5500	1500	5500	1550	5500	1500
320x90	40	6600	1850	6600	1800	6200	1750	6200	1750
	90	5800	1650	5800	1600	5800	1650	5800	1600

Wind Speed		N1, N2 & N3				C1, C2 & C3			
Rafter spacing (mm)		600		1200		600		1200	
		Maximum Rafter span + overhang span (mm)							
Member size DxB (mm)	Roof & ceiling mass (kg/m <sup>2</sup> )	Span	Overhang	Span	Overhang	Span	Overhang	Span	Overhang
		Single span				Single span			
360x90	40	7000	2050	7100	2050	6700	1850	6700	1850
	90	6200	1800	6200	1800	6200	1800	6200	1750
240x120	40	5800	1650	5900	1600	5600	1650	5600	1600
	90	5000	1500	5000	1500	5000	1500	5000	1500
280x120	40	6400	1950	6400	1950	6200	1800	6200	1800
	90	5600	1750	5600	1700	5600	1750	5600	1700
300x120	40	6700	2100	6700	2050	6500	1900	6500	1900
	90	5900	1850	5900	1850	5900	1800	5900	1800
320x120	40	6900	2200	6900	2200	6800	1950	6800	1950
	90	6100	1950	6100	1950	6100	1850	6100	1850
360x120	40	7400	2450	7400	2450	7400	2050	7300	2050
	90	6500	2150	6600	2150	6600	1950	6600	1950

**NOTES:**

1. D = member depth, B = member breadth, NS = not suitable.
2. The above table was based on a batten spacing of 900 mm
3. Minimum backspan = 200% of overhang
4. Maximum birds mouth depth = 30% of depth
5. End bearing length = 35 at end supports and 35 mm. Subscript values indicate the minimum additional bearing length where required to be greater than 35 mm at end support
6. Construction loads shall not be applied to overhangs until a 190 x 19 mm (min) timber fascia or other fascia of equivalent stiffness is rigidly and permanently attached to the end of rafter overhangs
7. Not all sizes of SmartLam GLT15S in this table are stocked in each state. Please check with your supplier before ordering
8. Table does not list all available SmartLam GLT15S sizes. See page 11 for full list of sizes

**SMARTFRAME**<sup>®</sup>  
POWERED BY INNOVATION



Sales 1800 33 77 03  
Technical support 1300 666 690



tilling.com.au