

SmartJoist® Design Guide



Table of Contents

Scope of this publication and engineering Certification	1
General Information—About floor performance	3
Recommended maximum spans	
- Table 1	4
- Table 2	4
- Table 3	5
- Table 4	5
SmartJoist design/effective span	6
Safety and SmartJoists installation	7
Handling and storage	7
Durability and exposure to moisture	8
SmartJoist—General Information	End nailing, rimboard and sheet nailing
SmartJoist floor construction details	8
	1. Forces at SmartJoist supports
	9
	2. End support blocking
	1. Simplified solution
	10
	2. Engineering Solution
	11
SmartJoist/SmartRim blocking capacities	13
Penetrations within SmartJoist/SmartRim blocking	13
Joist hangers	14
General connector installation details	17
Field repair to damaged SmartJoists	18
Typical SmartJoist floor framing	19
Typical SmartJoist floor construction details	
	- End blocking
	19
	- Interior loadbearing and bracing walls
	19
	- Non loadbearing cantilevers
	20
	- Backer and filler blocks
	21
	- Concentrated loads on SmartJoists
	23
	- Multiple SmartJoist members
	23
	- SmartJoist multi-joist clips
	23
	- Limited end notching at supports
	24
	- Example fixing to steel beams
	25
	- Example fixing to masonry walls
	26
Joist/beam connections supporting concentrated loads	26
Multiple member beams supporting SmartJoists	27
Rafter cut for SmartJoist floor joists	30
Design for Fire	30
SmartJoist floor setdowns	31
Building envelope water tightness	31
Brick ledge cantilever construction details	32
SmartJoist hole and duct charts	35
Openings within SmartJoist floors	36
SmartJoist cantilevers supporting loadbearing walls	37
SmartJoists under parallel load bearing walls	39
Tie down and bracing wall details	41
Cyclone rod tie down for cantilevered floors joists	44
SmartJoists as rafters	45
SmartJoist box gutter details	46

Table of Contents (cont'd)

SmartFrame bevelled bearing plates	47
Strong-Drive® SDWC Truss screws	47
Typical SmartJoist roof details	48
SmartJoist roof cassettes	51
Safe loading of materials on SmartJoist working platforms	52
Fire safety and acoustics Class 2 and class 3 buildings	53
Preservation treatments	54
Adhesive and formaldehyde fact sheets	55

Scope of this publication

This Design Guide and Load Tables assists in the selection of SmartJoists for most of the common structural arrangements met in domestic construction. The Tilling Timber website (www.tilling.com.au) and SmartFrame software, in conjunction with this manual, provides an unparalleled level of design capacity for SmartFrame engineered timber products.

While specific details are given on suitable methods of developing lateral restraint, the methods of providing adequate support, adequate anchorage against wind uplift and overall structural stability are outside the scope of this publication.

Information on the above matters can be obtained from AS 1684 Residential timber-framed construction code or from a structural engineer experienced in timber construction.

Tilling Timber Pty Ltd has structural engineers on staff who can be contacted for advice on matters concerning the use of its engineered timber products in timber construction on the tech support helpline on 1300 668 690 or at techsupport@tilling.com.au.

Substitution of other products

All load tables in this document are designed using in-grade tested properties for I-Joists distributed as SmartJoists. Other manufacturers I-Joists may have different properties and, therefore, cannot be designed using these span tables.

Copyright

Copyright of this publication remains the property of Tilling Timber Pty Ltd, and reproduction of the whole or part of this publication without written permission from Tilling Timber Pty Ltd is prohibited.

NCC Evidence of suitability

Part A5.2 of the NCC documents the six (6) methods a manufacturer may use to support that the use of a material, product, form of construction or design meets a *Performance Requirement* or a *Deemed-to-Satisfy Provision*.

Two (2) of the six methods are adopted below to provide *Evidence of suitability* that SmartJoists meet the Performance Requirements.

A5.2(1)(e) A certificate or report from a *professional engineer* or other *appropriately qualified person*.

As a professional engineer, qualified and experienced in timber engineering, I certify that the use of the SmartJoist members as shown in these tables, and installed in accordance with the provisions of this Design Guide, will comply with the requirements of the Building Code of Australia. These span tables have been prepared in accordance with standard engineering principles, the relevant test reports and Australian standards:

- AS 1720.3 Timber structures Part 3: Design criteria for timber-framed residential buildings
- AS 1720.1 Timber Structures - Design Methods
- AS 4055 Wind loads for Houses
- ASTM D 5055 Standard specification for establishing and monitoring structural capacities of prefabricated wood I-Joists
- ISO 22389 -1 Timber Structures - Bending strength of I-beams. Part 1: Testing, evaluation and characterization

Craig Kay RPEng, BDC0730, PE0001869, RPEQ5100, CC5635C, NER
National Product Engineer

A5.2(1)(f) Another form of documentary evidence, such as but not limited to a *Product Technical Statement*.

A SmartJoist *Product Technical statement* is available on request from the techsupport helpline on 1300 668 690 or at techsupport@tilling.com.au.

This Product Technical Statement —

- (i) demonstrates that the SmartJoist fulfils the performance requirements of the NCC; and
- (ii) sets out the basis on which it is given and the extent to which relevant standards, specifications, rules, codes of practice or other publications have been relied upon to demonstrate it fulfils specific performance requirements of the NCC.



The information contained in this product brochure is current as Aug 2021 and is based on data available to Tilling Timber Pty Ltd at the time of going to print. Tilling Timber Pty Ltd has used its reasonable endeavours to ensure the accuracy and reliability of the information contained in this document and, to the extent permitted by law, will not be liable for any inaccuracies, omissions or errors in this information nor for any actions taken in reliance on this information. Tilling Timber Pty Ltd reserves the right to change the information contained in this document without prior notice. It is important that you call the tech support helpline on 1300 668 690 to confirm that you have the most up to date information available.

The SmartFrame Engineered Wood System is made up of:

- World class engineered timber products:
 1. SmartJoist
 2. SmartLVL
 3. SmartLam GLT
 4. Tecbeam
- Unique SmartFrame Structural Design, Detailing and Estimating Software
- Full engineering support and technical advice from experienced engineers and field staff free of charge on our unique tech support helpline 1300 668 690.

SmartJoists

The strength is in the engineering: Strong. Stiff. Reliable. SmartJoists are engineered for heavy performance. We start with ultrasonically graded LVL, bonded with exterior adhesive for more load carrying capacity.

The webs are made from stable, strong Oriented Strand Board (OSB) for superior strength and consistent performance. SmartJoists are more uniform than solid sawn joists. They stay straighter and are manufactured with no camber, so there is no chance of crown down or upside down installation. They resist shrinking, twisting, warping and splitting for squeak resistant floors and quality roofs and ceilings.

Holes may be easily cut in the web according to the tables on page 30, allowing ducts and utilities to be run through the joists. Pre-punched 40 mm knockout holes are provided in the web for small diameter services or wiring.

Save Time and Money: Because they weigh less than solid sawn joists, SmartJoists are easier to install, saving construction time and cost. Their greater load carrying capacity allows you to space them further apart, so it takes fewer to build the average floor or roof.

“The strength is in the engineering”

And with five (5) depths from 200 to 400 mm, you will never have to compromise your design. So whether your plans call for cantilever beams in balconies, cathedral roofs or high pitched roof slopes, SmartJoists are the perfect choice.

An Environmentally Sound Choice: In addition to being cost effective, SmartJoists are also an environmentally sound choice because they are made of a renewable resource – wood. So they are a better choice for building.

SmartJoists have a certified Chain of Custody system to PEFC.

SmartFrame Software: Our unique SmartFrame design, detailing and estimating software offers you unparalleled design and estimating capabilities with engineered timber. You will get accurate designs for a wide variety of applications, printouts and joist layouts.

Limitations of use - SmartJoists: SmartJoists are to be used in dry interior environments only, fully enclosed from exposure to exterior moisture. SmartJoists are suitable for subfloor applications provided that the subfloor space is ventilated as per the NCC requirements. This means that SmartJoists must not be exposed to environments where the equilibrium moisture content of the joist will exceed 18%. Tilling Timber will not guarantee SmartJoists that have been left exposed to the weather either prior to or during construction for more than 90 days.

Detailing such as cladding or lining must be used in moisture laden environments (commercial kitchens, bathrooms, wet industrial areas, saunas, swimming pool and spa rooms etc.) and constructed in such a way as to prevent exposure of the SmartJoist to moisture.

SmartJoists may be used in applications which are often exposed externally (gable ends, eaves, floor joists applications in elevated houses, cantilevered joists etc.) but must be sufficiently enclosed with a suitable cladding, lining etc. to completely prevent the exposure of the SmartJoist to moisture.

SmartFrame Consumer Product Warranty

Tilling Timber guarantees that SmartFrame Engineered Timber products have been manufactured to exacting standards and are free from defects in workmanship and materials.

At Tilling Timber, we take great pride in SmartFrame products, so if you bring to our attention problems such as squeaks that you believe are caused by our products, we guarantee that a technical representative will contact you promptly to evaluate the issues and provide advice to help solve the problem.

Providing that any SmartFrame product is correctly designed, handled and installed, any problem caused by an unlikely defect will promptly be remedied at no cost to you.

This guarantee remains valid for the expected life of your home.

Tilling Timber Pty Ltd
31-45 Orchard Street
Kilsyth Vic 3137

Priority call: 1300 668 690 e-mail: techsupport@tilling.com.au

General information - about floor performance

The “feeling” that is identified when a person walks on a floor is very subjective. Some people want to feel a very stiff floor and others want some “give” so that it softens the footing. When people say the floor “bounces”, it may be vibrating. This sensation is often caused by lack of dead load such as furniture, direct applied ceilings or other materials to absorb or dampen the vibration.

AS 1720.3 standard includes as an upper limit, a 1.0 kN static load applied at mid-span as a serviceability equation to simulate the foot force effect on the design of floor joists. The differential deflection caused by this 1 kN load is limited to 2 mm.

This criteria was developed for solid section floor joists up to 6 m spans, and in some cases, experience is now showing that at the 2 mm limit, the floor performance of lightweight I-Joist floors (especially without ceilings below e.g. subfloors) may be considered unfit for purpose by some people.

The two (2) alternative SmartJoist Span Table shown in this manual have been designed to meet the strength and serviceability criteria of:

- **Table 1 - AS 1720.3—2016** In this table the strength and serviceability limits of AS 1720.3—2016 have been used along with the recommended dynamic requirements.
- **Table 2 - SmartJoist Preferred Dynamics.** In this table the strength and serviceability limits of AS 1720.3—2016 have been supplemented with a EN 1995-1-1-2004 serviceability equation to better model foot force effects on I-Joist floors. This approach has been demonstrated to produce stiffer floors for those wanting a firmer feel in their timber floor.

Both tables list MAXIMUM recommended joist spans, and therefore shorter spans in most cases should produce stiffer floors.

Factors that can affect floor dynamic performance

- The choice of flooring system
- The depth, stiffness and mass of the joists
- Spacing of joists
- Fixing of sheathing to joists
- Stiffness and mass of floor sheathing
- Mass and stiffness of ceiling materials
- Method of installation
- Location and type of internal partitions and furniture

Factors that can improve floor dynamic performance

- Glue/nailed and glue/screw floors will perform better than floors secured by nails alone.
- Deflection of the sheathing material between joists can be reduced by decreasing the joist spacing or using a thicker and/or stiffer sheathing.
- Proper installation is essential for dependable performance. Adequate and level support for the joists is necessary, as is correct fastening of the joists and sheathing.
- The installation of a ceiling to the bottom flange of the joists or a similar mass/loading sharing system.

While between joist blocking has been traditionally used to provide some improvement to floor dynamic performance of solid timber joists, both testing and long experience show limited if any improvement to the dynamic performance by midspan blocking of I-Joist floor systems with simple blocking.

If floor dynamic performance is a concern to either the client, designer or contractor, then the above variables can be altered, or additional methods be incorporated to improve dynamic performance.

Further information on the dynamic performance of lightweight timber floors can be obtained by calling the tech support helpline on 1300 668 or at techsupport@tilling.com.au.



Large area ceramic tiled floors

The modern trend to large size ceramic tiles has introduced a new design challenge for all floor substrates. Smaller numbers of grouted joints between larger tiles means that any deflection of the floor has to be larger per grouted joint, thus increasing the probability of cracking.

AS 3958.1—2007 (includes amendment 1-2010) Ceramic tiles Part 1: Guide to the installation of ceramic tiles limits the total deflection of the floor (Dead Load + Live Load) to L/360. This supplementary deflection limit is not one that is normally considered in the design of timber floors.

The spans listed within **Tables 2-4** meets the additional AS 3958.1—2007 Ceramic tiles Part 1: Guide to the installation of ceramic tiles deflection limits.

Recommended maximum spans for lightweight residential floors

General domestic - 1.5 kPa

Loadings: Permanent Loading G: self weight + 40 kg/m² + 0.5 kPa of live load permanently applied, live load Q: 1.5 kPa or 1.8 kN point live load

In compiling the span tables in this manual, the requirements of the relevant Australian standards and codes along with established Industry standard design guidelines for Residential Construction have been followed. In particular, the following codes and references have been used:

- AS 1720.3 Timber structures. Part 3: Design criteria for timber-framed residential buildings
- AS 1720.1 Timber Structures - design methods
- AS 4055 Wind loads for houses
- AS/NZS 4063 Characterisation of structural timber
- ASTM D 5055 Standard specification for establishing and monitoring structural capacities of prefabricated wood I-Joists

Serviceability criteria:

Max permanent load deflection - lesser of span / 300 or 15 mm ($j_2 = 2$)
 Max live load deflection - lesser of span / 360 or 9 mm

Table 1 - AS 1720.3—2016 Floor dynamics criteria

1. Minimum floor Natural Frequency - 8 Hertz
2. Maximum differential deflection between joists of 2 mm under a concentrated load of 1.0 kN mid-span to simulate the foot force effect on the design of floor joists.

Joist spacing (mm)		300	400	450	600	300	400	450	600
SmartJoist code	Self weight (kg/m)	Maximum recommended floor joist span (mm)							
		Single span				Continuous span			
SJ20044	2.7	4750	4400	4200	3750	5400	5000	4800	4300
SJ24040	2.8	5200	4800	4650	4250	5900	5550	5300	4900
SJ24051	3.2	5500	5050	4950	4550	6200	5700	5600	5100
SJ24070	4.0	5900	5450	5300	4900	6600	6150	6000	5500
SJ24090	5.1	6250	5800	5600	5200	7000	6500	6350	5850
SJ25570	4.4	6100	5650	5500	5100	6900	6400	6200	5750
SJ30040	3.1	5900	5450	5300	4900	6650	6100	5900	5650
SJ30051	3.6	6250	5800	5600	5200	7000	6500	6250	5900
SJ30070	4.4	6700	6200	6050	5600	7500	6900	6700	6300
SJ30090	5.6	7150	6600	6400	5900	7950	7350	7100	6700
SJ36058	4.5	7200	6700	6500	6000	8150	7500	7250	6900
SJ36090	6.0	7900	7300	7100	6550	8850	8150	7900	7500
SJ40058	4.5	7550	7000	6800	6300	8750	8150	7900	7300
SJ40090	6.3	8400	7750	7550	6950	9400	8650	8400	7800

Table 2 - SmartJoist Preferred floor dynamics criteria

1. Minimum floor Natural Frequency - 8 Hertz
2. Maximum differential deflection between joists of:
 - 1.8 mm for spans ≤ 4200 mm
 - $17,500/L^{1.1}$ for span ≥ 4200 mm (for L in mm)
 under a concentrated load of 1.0 kN mid-span to simulate the foot force effect on the design of floor joists.

Joist spacing (mm)		300	400	450	600	300	400	450	600
SmartJoist code	Self weight (kg/m)	Maximum recommended floor joist span (mm)							
		Single span				Continuous span			
SJ20044	2.7	4650	4200	3900	3600	5400	4750	4500	4150
SJ24040	2.8	5100	4500	4350	4050	5900	5200	4900	4500
SJ24051	3.2	5400	4800	4650	4350	6200	5500	5200	4800
SJ24070	4.0	5850	5250	4950	4650	6700	5900	5600	5100
SJ24090	5.1	6150	5550	5250	4950	7150	6200	5950	5450
SJ25570	4.4	6150	5400	5100	4800	6900	6100	2800	5300
SJ30040	3.1	5850	5100	4950	4650	6700	5900	5600	5150
SJ30051	3.6	6150	5400	5250	4950	7100	6200	5900	5450
SJ30070	4.4	6750	5850	5700	5250	7650	6700	6350	5850
SJ30090	5.6	7050	6300	6000	5550	8100	7100	6750	6200
SJ36058	4.5	7200	6300	6150	5700	8250	7200	6850	6300
SJ36090	6.0	7950	6900	6600	6150	9000	7850	7450	6850
SJ40058	4.5	7500	6600	6300	6000	8700	8100	7800	7350
SJ40090	6.3	8400	7350	7050	6600	9500	8300	7900	7250

Recommended maximum spans for residential floors with ceramic tiles

General domestic - 1.5 kPa

Table 3 - SmartJoist –65 kg/m² - grout and tiled floor

1. Minimum floor Natural Frequency - 8 Hertz
2. Maximum differential deflection between joists of:
 - 1.8 mm for spans ≤ 4200 mm
 - 17,500/L^{1.1} for span ≥ 4200 mm
 under a concentrated load of 1.0 kN mid-span to simulate the foot force effect on the design of floor joists.
3. Total deflection of the floor (Dead Load + Live Load) to L/360 as per AS 3958.1—2007 (includes amendment 1-2010) Ceramic tiles Part 1: Guide to the installation of ceramic tiles

Loadings: Permanent Loading G: self weight + 65kg/m² + 0.5 kPa of live load permanently applied, live load Q: 1.5 kPa or 1.8 kN point live load

Joist spacing (mm)		300	400	450	600	300	400	450	600
SmartJoist code	Self weight (kg/m)	Maximum recommended floor joist span (mm)							
		Single span				Continuous span			
SJ20044	2.7	4500	4050	3900	3450	5400	4650	4500	4050
SJ24040	2.8	5100	4500	4350	3900	5850	5100	4800	4500
SJ24051	3.2	5400	4800	4650	4200	6150	5400	5100	4800
SJ24070	4.0	5850	5250	4950	4650	6750	5850	5500	5100
SJ24090	5.1	6150	5550	5250	4950	7200	6300	5850	5400
SJ25570	4.4	6000	5400	5100	4800	6900	6100	5700	5250
SJ30040	3.1	5850	5100	4950	4650	6700	5850	5550	5100
SJ30051	3.6	6150	5400	5250	4950	7050	6150	5850	5400
SJ30070	4.4	6600	5850	5700	5250	7600	6600	6300	5850
SJ30090	5.6	6900	6300	6000	5550	8100	7050	6750	6150
SJ36058	4.5	7200	6300	6150	5700	8200	7200	6750	6300
SJ36090	6.0	7650	6900	6600	6150	9000	7800	7500	6900
SJ40058	4.5	7500	6600	6300	6000	8500	7500	7050	6600
SJ40090	6.3	8250	7350	7050	6600	9600	8250	7800	7200

Table 4 - SmartJoist –135 kg/m² - 40 mm grout and tiled floor

1. Minimum floor Natural Frequency - 8 Hertz
2. Maximum differential deflection between joists of:
 - 1.8 mm for spans ≤ 4200 mm
 - 17,500/L^{1.1} for span ≥ 4200 mm
 under a concentrated load of 1.0 kN mid-span to simulate the foot force effect on the design of floor joists.
3. Total deflection of the floor (Dead Load + Live Load) to L/360 as per AS 3958.1—2007 (includes amendment 1-2010) Ceramic tiles Part 1: Guide to the installation of ceramic tiles

Loadings: Permanent Loading G: self weight + 135 kg/m² + 0.5 kPa of live load permanently applied, live load Q: 1.5 kPa or 1.8 kN point live load

Joist spacing (mm)		300	400	450	600	300	400	450	600
SmartJoist code	Self weight (kg/m)	Maximum recommended floor joist span (mm)							
		Single span				Continuous span			
SJ20044	2.7	3750	3300	3150	2850	4700	4400	4300	3900
SJ24040	2.8	4200	3750	3600	3300	5200	4850	4700	4350
SJ24051	3.2	4500	4050	3900	3450	5500	5100	4950	4600
SJ24070	4.0	5100	4500	4350	3900	5850	5450	5250	4900
SJ24090	5.1	5400	4950	4650	4200	6100	5700	5550	5150
SJ25570	4.4	5250	4800	4500	4050	6100	5650	5500	5100
SJ30040	3.1	5100	4500	4350	3900	5900	5500	5350	4950
SJ30051	3.6	5400	4950	4650	4200	6200	5800	5600	5250
SJ30070	4.4	5850	5400	5250	4650	6600	6200	6050	5600
SJ30090	5.6	6150	5850	5550	5100	6950	6500	6300	5900
SJ36058	4.5	6300	5850	5700	5250	7150	6700	6450	6000
SJ36090	6.0	6900	6450	6300	5850	7700	7200	6950	6450
SJ40058	4.5	6600	6150	6000	5550	7500	7050	6850	6350
SJ40090	6.3	7350	6750	6600	6150	8150	7600	7400	6900

Recommended maximum spans for residential floors (cont'd)

Flooring

Spans are suitable for solid timber, particle board and ply flooring. Floor sheathing glued and nailed to the joists will improve floor rigidity. Where a heavy overlay material is to be applied, such as thick mortar bed tiled or slate floors, the permanent load allowance should be increased to 1.2 kPa. A reduction of joist spacing can be used to accommodate this extra permanent load. A satisfactory result can be achieved by adopting the maximum spans for 600 mm and 450 mm spacing but installing the joists at 450 mm and 300 mm spacing respectively.

Continuous spans

For beams which are continuous over two unequal spans, the design span and the "resultant span description" depend on the percentage difference between the two spans as shown below:

Span difference	Effective span	Resultant span description
10% max	main span	continuous
10 - 30%	1.1 x main span	continuous
above 30% diff	main span	single

$$\text{span difference} = \frac{(\text{main span} - \text{second span})}{(\text{main span} + \text{second span})} \times 100$$



SmartJoist Design / Effective span

Normal structural analysis uses the centreline representation of the member. The term "span" can be defined in a number of ways and these are defined as follows:

Clear Span. This is the distance between the faces of any support. It is generally the one easiest to measure and read from the drawings.

Nominal span/centre-line span. This is the distance between the centre of the supports. This span is used to determine bending moments and deflections for continuous spanning members.

Design span/Effective span. This is the span used for single span members to determine the bending moment, the slenderness of bending members and the deflections. In NZS 3603 this is the dimension referred to as "L", and is defined below:

Design span/Effective span is the distance between -

- The centre of the bearing at each end of a beam where the bearing lengths have NOT been conservatively sized
- The centre of notional bearing that have been sized appropriately, where the size of the bearing IS conservative.

Diagram (a) shows beam where bearings have been designed appropriately. The effective span is taken as the distance between the centre of each bearing area

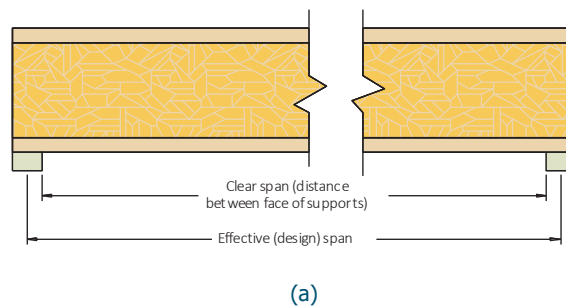
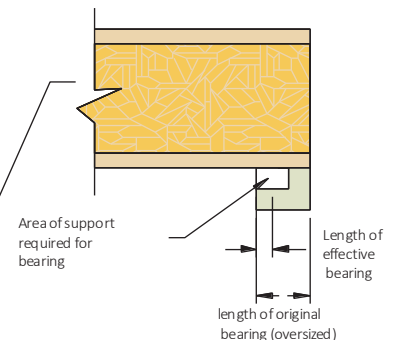
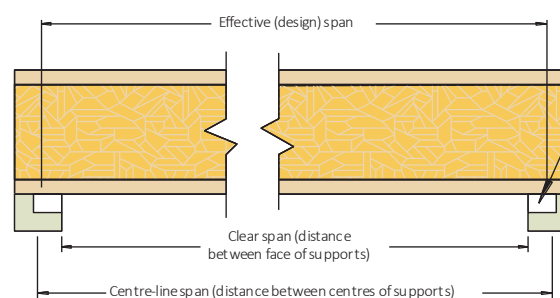

Diagram (b) shows beam where bearings at each end have been oversized. (This is frequently the case for beams that bear onto brickwork or concrete walls where the thickness of the wall is in excess of the area required to give the beam bearing capacity). To find the correct effective span:

1. Calculate the minimum bearing required to carry the loads satisfactorily
2. Add minimum bearing length to "clear span" distance



(b)

Safety Warning

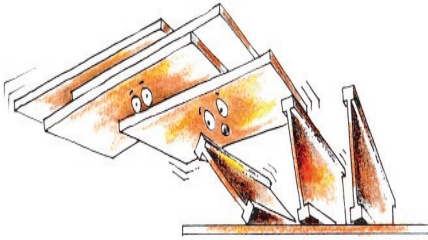

Do not allow workers or loads on SmartJoists until all blocking, hangers, rim joists, nailing and temporary bracing are installed as specified below. Serious accidents or injury can result from failure to follow these guidelines.



Accidents can be avoided under normal conditions by following these guidelines:

1. Brace each joist as it is erected. Joists must be nailed to supports and all hangers, blocking, rim joists. X - bridging at supports must be completely installed and properly nailed. (see general notes and details)
2. Brace the ends of cantilevers (overhangs) with closure panels, rim joist or x - bridging (see general notes and details)
3. Lateral brace the top flange of each joist, to prevent sideways buckling or rollover which may occur under light construction loads, such as a worker and/or a layer of un-nailed sheathing. Fully installed permanent sheathing or temporary struts to the top flange of each joist (see 'Typical SmartJoist floor framing') can accomplish lateral bracing. Temporary struts must be nailed to a lateral restraint at the end of bay such as a braced wall or temporary (or permanent) sheathing nailed to the first 1200 mm of the joist at the end of the bay (see 'Typical floor or roof framing')
4. Permanent sheathing must be completely installed and properly nailed before additional loads can be placed on the system
5. The integrity and safe use of these products can be seriously impaired if they are damaged. Do not install any damaged products. Contact your SmartFrame representative or the tech support helpline on 1300 668 690 if any product damage is noted.

Handling and storage of SmartJoists

- Store SmartJoists flat on a hard, dry surface
- If surface isn't paved, the ground should be covered with a polythene film
- Keep covered with waterproof material that allows bundles to "breathe"
- Use bearers (bolsters) between the ground and the first bundle (4 metre max spacing)
- Use 100 x 50 timber flat between bundles at same spacing as bolsters
- Take great care to rewrap remaining material after opening bundles
- Wood "grows" in thickness and depth when allowed to get wet....KEEP DRY!
- Wood with high MC has short term reduction in Characteristic Strengths KEEP DRY!
- Under NO circumstances are stored SmartJoists to be in contact with the ground.

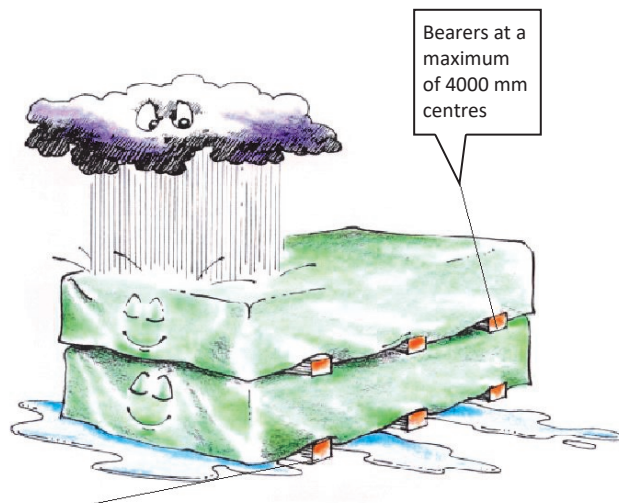

Use bearers to keep stacked material away from damp surfaces. Align bearer vertically

SmartJoists should be stacked in the upright position to avoid any damage during handling or storage.

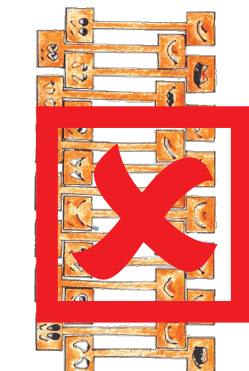
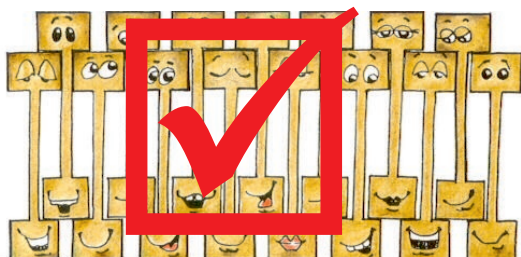

Durability and exposure to moisture

SmartJoists are manufactured with Douglas Fir (Oregon) flanges with OSB webs, both having a durability rating of class 4, the equivalent rating as some Ash type Eucalypts. Untreated SmartJoists should therefore not be used where the equilibrium moisture content is likely to remain above 18 % for an extended period.

Untreated SmartJoists are suitable in the **internal, fully protected, ventilated** and the **external above ground, protected** zones of the structure as shown in appendix B of AS 1684. Untreated SmartJoist is not suitable for **external above ground, exposed** or humid indoor conditions, such as swimming pool enclosures.

Moisture effects on SmartJoists

SmartJoist is supplied WITHOUT any short term construction sealer, but once framed into a structure may be exposed to the weather for a limited time (not greater than 3 months) without negative affect, BUT, it may exhibit some effects of this exposure.

The wood fibre in SmartJoists, like all wood products, is hygroscopic, which means it has an affinity for water. The wood fibre in SmartJoist will readily take up and release moisture in response to changes in the local environment. Moisture exposure will lead to dimensional change. While the products will withstand normal exposure, excessive exposure during distribution, storage or construction may lead to dimensional changes that affect serviceability. These changes include twisting, bowing or expansion to dimensions to beyond the specified tolerance of the product in the “as-manufactured” condition.

As an organic material, mould and mildew may grow on untreated wood products if moisture is present. Prolonged periods of high moisture may also support the growth of wood decay fungi, which is another reason to follow proper methods of storage and handling of SmartJoists.

The table below shows the moisture content of SmartJoists as a function of humidity.

Moisture content of wood products % ⁽¹⁾		
Relative Humidity %	LVL Flange MC	OSB web
10	1.2	0.8
20	2.8	1.0
30	4.6	2.0
40	5.8	3.6
50	7.0	5.2
60	8.4	6.3
70	11.1	8.9
80	15.3	13.1
90	19.4	17.2

(1). Approximate moisture content at 21°C

Wetting during construction may lead to temporary elevated moisture content and dimensional changes. Once covered, the SmartJoists will ultimately dry and re-equilibrate to the ambient humidity conditions, but some expansion or swelling may remain after drying.

SmartJoists - General information

- Joists should be accurately placed at not more than the nominated maximum centre to centre spacing so as to provide the support required for flooring and load bearing walls or concentrated loads
- Supports shall be level, dry and have at least the rigidity implied by good framing practice and/or the design criteria specified for supporting components in AS 1684. (A moisture barrier is recommended where support is directly to masonry or brickwork.)
- Except where otherwise noted, 30 mm minimum bearing is required at joist ends and 42 mm minimum bearing is required at intermediate supports.
- Nail joists at each bearing with 2 of 3.15 Φ x 65 nails, using one each side placed 30 mm from the end to avoid splitting as per detail below.

- 3.15 Φ x 65 nail, use 1 off 3.75 Φ x 75 nail top and bottom with joists with 58, 70 or 90 mm wide flanges.
- SmartRim - toe nail to bearing plate with 3.15 Φ x 65 nails at 150 centres or 4.5 Φ x 75 nails at 300 centres. Nail rim to the end of the top and bottom flanges of each SmartJoist with 1 3.15 Φ x 65 nails.
- Sheathing nailing to top flange (Joists must be fully braced before sheathing is nailed or screwed) is detailed below:

Do NOT start toe nail into the corner of the flange or the top of the flange.

MAXIMUM Nail diameter 3.15 mm

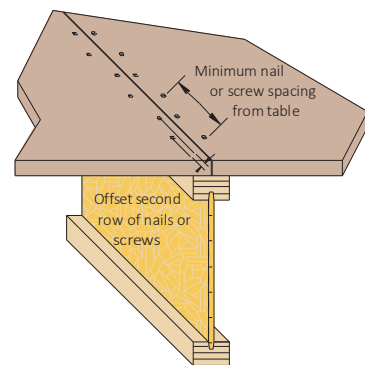
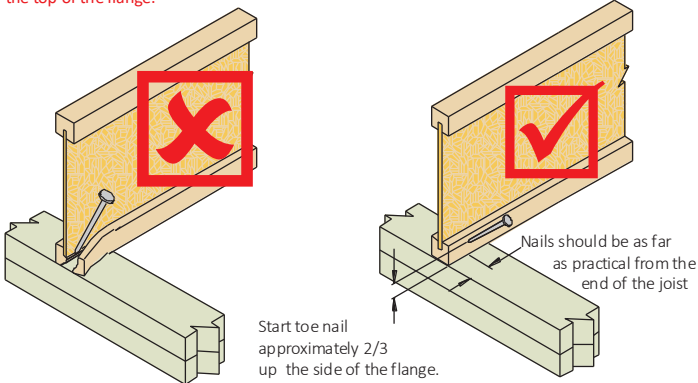

- SmartJoist blocking or SmartRim - face nail to bearing plate with 3.15 Φ x 65 nails at 150 mm centres. Nail rim joist to the end of the top and bottom flange of each SmartJoist with 1 off

Minimum single row fastener spacing into SmartJoist flanges					
Fastener type and size	SmartJoist flange width				
	40 mm flange	44 mm flange	51 mm flange	58-70 mm flange	90 mm flange
Nails					
2.8 x 60	75	75	50	50	50
3.15 x 60	100	90	75	75	75
Screws					
9g x 45	150	150	75	75	75
10g x 50	150	150	100	75	75

SmartJoists - General notes (Cont'd)

- Do not use nails or screws larger than those shown above when attaching sheathing to flanges of SmartJoists
 - Minimum nail spacing is shown above, maximum nail spacing is set by the flooring manufacturer, in absence of manufacturers data, 300 mm centres
 - Tighter effective nail spacing may be obtained by offsetting nail rows a minimum of 12 mm and maintaining a 10 mm minimum edge distance.
8. The top flanges must be kept straight within 10 mm of the true alignment
 9. All roof details are valid to a maximum angle of 35° (as per AS 1684)
 10. All nails are steel nails complying with AS 2334 - 1980 Steel nails - Metric series. Nail gun nails of similar length and diameter may be substituted for the above provided that they are manufactured with properties equivalent to the nails in the above code.
 11. Install all hangers to the manufacturers installation instructions, taking particular attention to the use of the correct nails. **Never use clouts or brads.**

SmartJoist floor construction details

Forces at SmartJoist supports

Within a structure, deep floor joists not only support gravity loads, but also racking and shear loads due to wind and possible seismic loadings.

Due to the larger depth to width ratio, and its small slender web cross section, any I-Joist needs to have its end bearing capacity and lateral stability considered as part of any design process.

Consideration of gravity loads alone, without due care, may lead to a building unable to resist the horizontal forces it will experience due to wind or seismic events.

Blocking of I-Joists at their support is a simple and effective way to provide joist stability, maintain verticality, and to provide horizontal racking resistance as well as vertical load transfer.

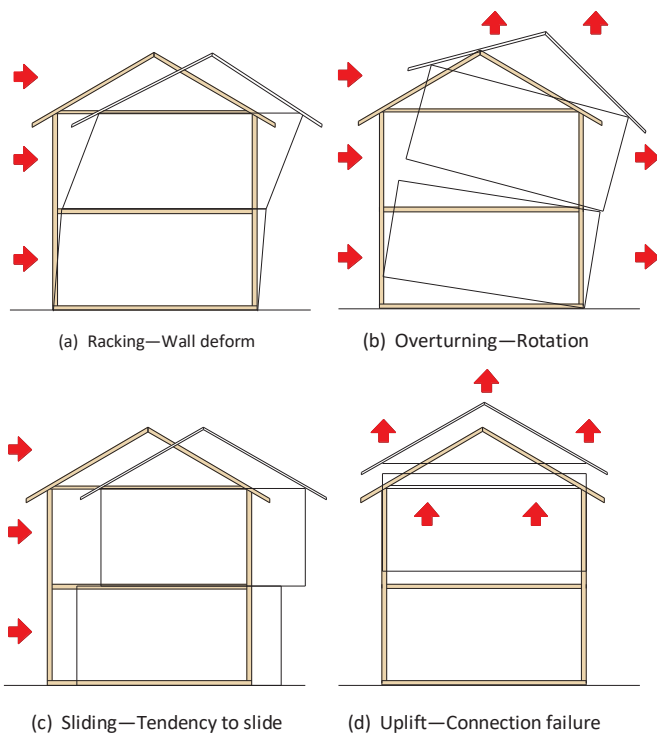

Note: Only Racking, Sliding and Gravity loads are considered in this Design Guide.

1. End support Blocking—General

Blocking within a structure, both at the end support of joists and at internal supports of joists, falls within two (2) quite distinct stages.

(a) Temporary or 'during construction' blocking: prevents roll over of joists during installation, provides a template to ensure joist verticality and thus a safe working platform. This is summarised as:

1. Temporary struts, fastened to top of SmartJoist, connected back to braced supports.
2. Temporary floor sheeting nailed to the first 1200 mm of joists at the end of the bay, in combination with struts, if no connection to a braced wall can be made.

Temporary or during construction blocking of the ends of joists over external wall must comply with the requirements as shown in the "SAFETY WARNING" on page 6 and as shown in the "TYPICAL SmartJoist FLOOR FRAMING" diagram on page 14.

(b) Permanent blocking: provides: adds to the benefits of temporary blocking to add resistance to racking loads through the floor diaphragm, transfer of vertical wall loads and torsional resistance to the end of the joist.

This permanent blocking/bracing provides:

1. A satisfactory mechanism to transfer racking loads through the floor diaphragm.
2. Vertical load transfer independent of the floor joist.
3. Support to the end of the floor sheeting (Platform floors only). Heavily loaded furniture legs have been known to cause large deflections and even failures at the edges of sheet flooring.
4. Torsional restraint to the end of floor joists, improving the joists structural performance.

2. Blocking requirement calculation methods

Two (2) methods are included in this Design Guide for the user to calculate the required amount end blocking to transmit the forces, both vertical and horizontal, through the floor space.

1. **Simplified Solution (Deemed to satisfy)**
2. **Engineered Solution (more complex)**

SmartJoist blocking options

1. Simplified solution

The simplified solution for the end blocking of SmartJoists is to use SmartJoist blocking or SmartRim rimboard at the end of **ALL** joists that bear onto external loadbearing walls as per details F1-F3 and nailed as per "General Details" on page 7 of this Design Guide.

This method provides:

1. Transfer of vertical gravity loads through the floor plane (Except under heavily loaded columns and jamb studs see detail F30 A-C)

2. Provides adequate resistance to racking loads from wind
3. Prevents unsightly deflections of the edge of floor sheeting at the wall interface

Experience shows that a floor plane properly engineered to provide sufficient racking resistance and support for gravity loads, whether concentrated or uniformly distributed, requires a significant amount of blocking/rimboard, so to simply block the ends of all joists on exterior loadbearing walls is the simplest solution.

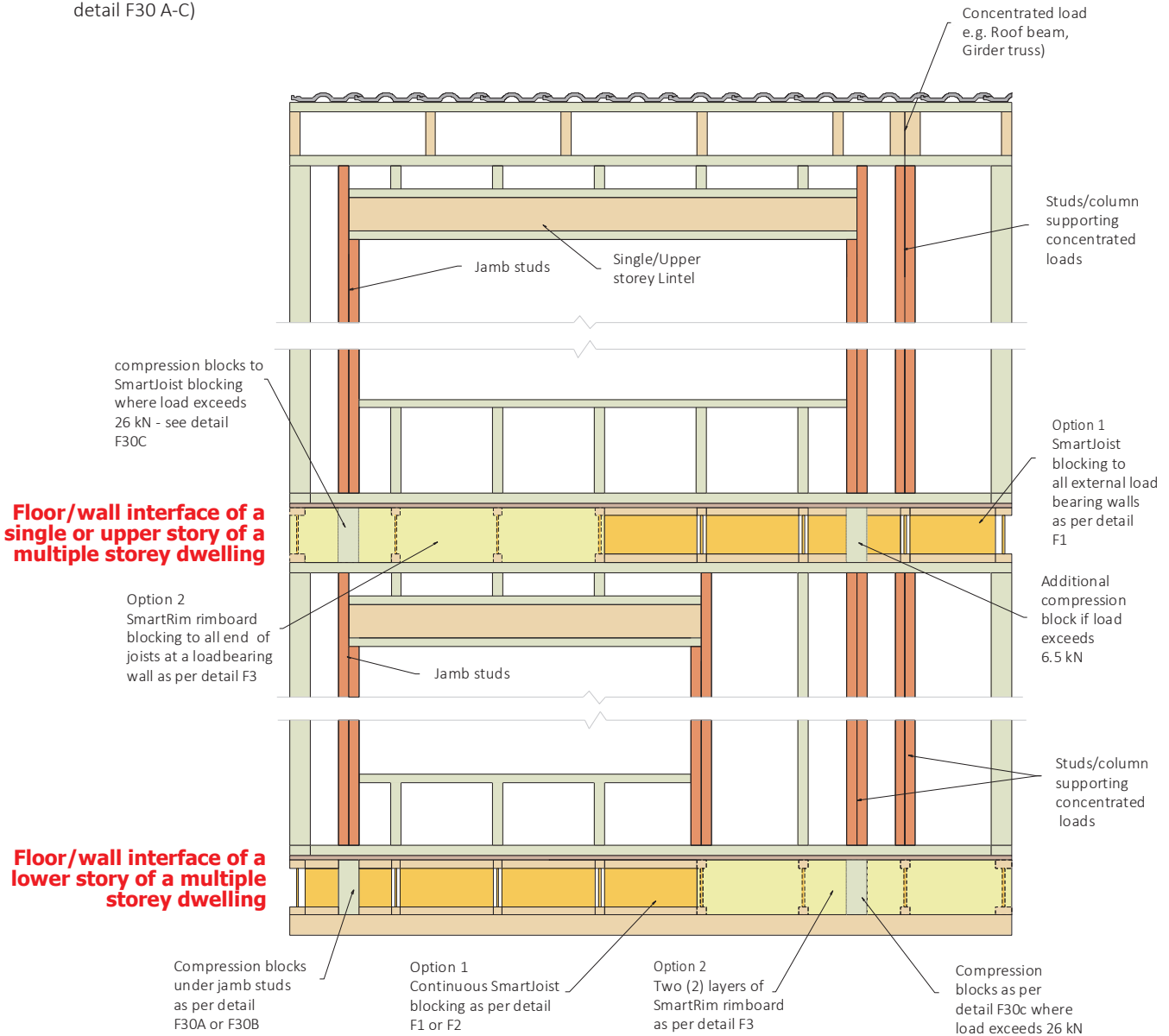

Fully blocked exterior walls

Wall plates in the frame are required to transfer vertical loads into the support structure below. These wall plates may be supported at 450 or 600 mm ctrs, thus acting as a beam between supports, bending about its weaker axis. When concentrated loads act at the centre of this wall plate, the bending and deflection effects can be quite significant.

The full blocking of external and load bearing walls, as shown in details F1-F4, can act as a beam transferring these loads to the support structure below, thus reducing the beam effect of the wall plates.

Unless there is a requirement for double wall plates for a reason OTHER than the beam effect between supports, walls blocked as per detail F1-F4 and general notes #2, #3, and #4 provide sufficient beam action to allow single wall plates

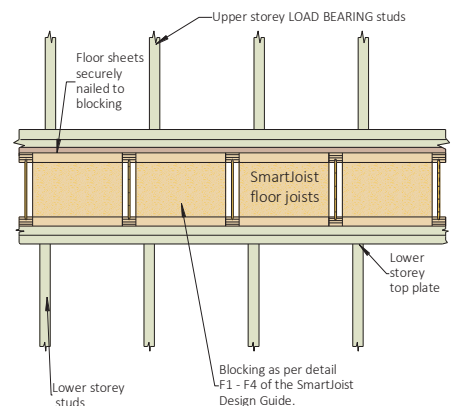

SmartJoist blocking options

2. Engineered Solution

A fully **Engineered Solution** MAY reduce the amount of end blocking of joists at an exterior wall, but requires engineering calculations and judgement to determine the correct number and type of blocking pieces to achieve the required resistance.

To use this method, designers will need to meet the following criteria via the use of Table 1 on the next page, **AND** carry out racking/sliding resistance calculations as well.

This method does NOT necessarily provide a solution to:

1. The link between fully blocked walls and the use of single wall plates. Unless fully blocked, the designer will need to consider the location of upper studs/in relation to lower studs/columns when considering to use one or multiple wall plates
2. The long term deflection of floor sheeting at walls (gap under the skirting board) when heavy furniture is placed against the wall.

The **Engineered Solution** involves a detailed analysis of the following:

1. The compression loads at both the ends of a SmartJoist at its support location, and in the case of a continuous span, the compression loads at the internal support
2. These loads vary considerably depending upon whether it involves:
 - a. Floor loads only
 - b. Floor loads plus compression loads from load bearing walls
 - c. Floor loads, compression loads from load bearing walls and/or concentrated compression loads from jamb studs/posts
3. Use of the table on the next page to calculate:
 - a. Minimum end and interior bearing lengths for the SmartJoists
 - b. Associated SmartJoist blocking requirements to meet the design loads
 - c. Requirement, where necessary, to add compression blocks.

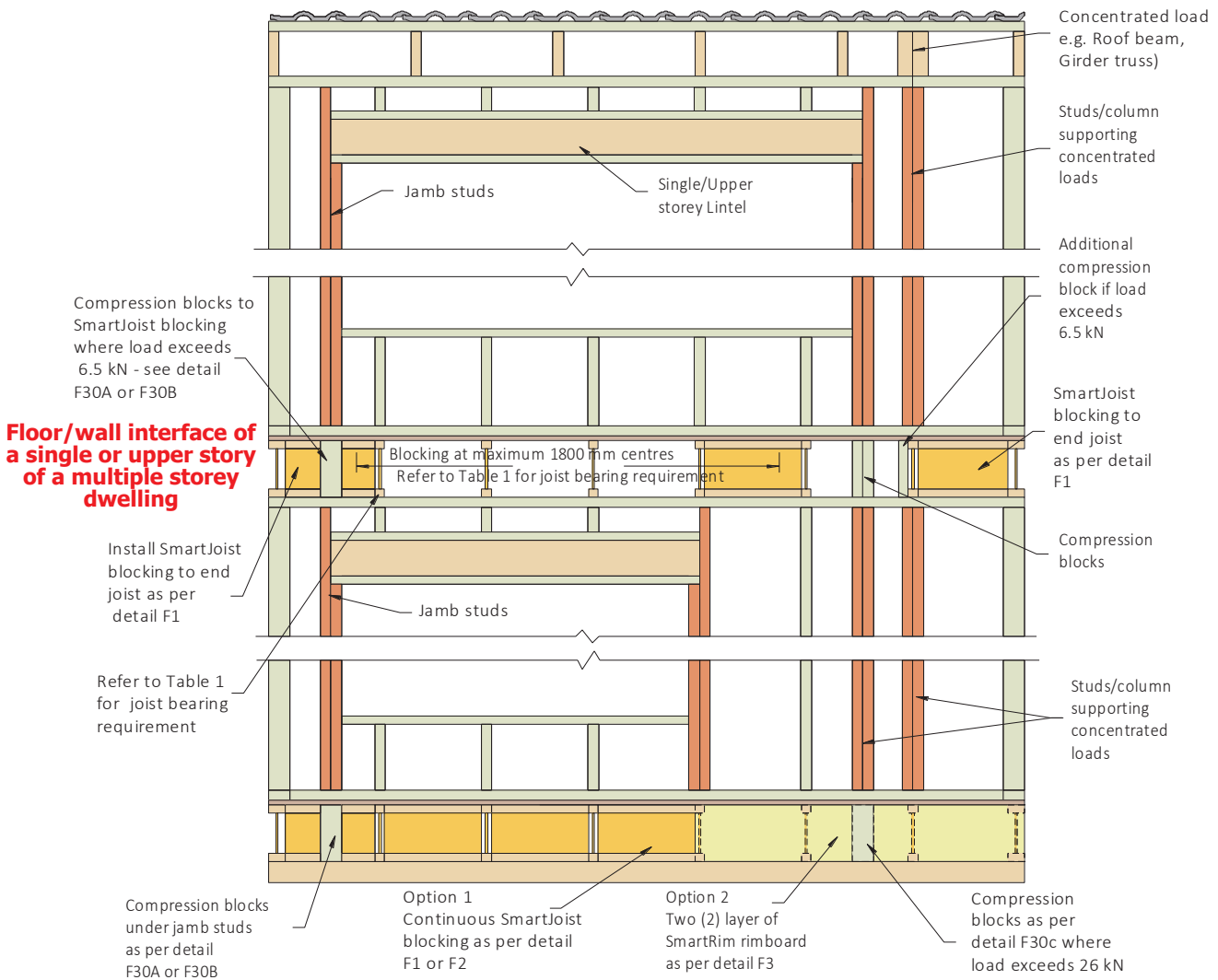

SmartJoist blocking options

TABLE 1 – Minimum bearing and blocking at supports for Gravity Loads ONLY

Loads at supports	End supports		Intermediate supports	
	Joist spacing (mm)		Joist spacing (mm)	
	≤ 450 mm	600 mm	≥ 450 mm	600 mm
1. Floor loads ONLY	Minimum bearing length (mm)			
	≥ 30 mm	≥ 45 mm	≥ 45 mm	≥ 65 mm
	Install intermittent blocking or equivalent			
2. Floor loads plus compression load from a single storey load bearing wall supporting roof only	Minimum bearing length (mm)			
	Sheet Roof (up to 40 kg/m ²)		≥ 45 mm	≥ 65 mm
	≥ 45 mm*	≥ 65 mm*		
	Tile roof (up to 90 kg/m ²)		≥ 45 mm	≥ 65 mm
	≥ 65 mm*	≥ 90 mm*		
*Install intermittent blocking or equivalent		Install continuous SmartJoist blocking		
3. Floor loads plus compression load from a two storey load bearing wall supporting roof and upper floor	Minimum bearing length (mm)			
	≥ 65 mm	≥ 65 mm	≥ 65 mm	≥ 65 mm
	Install continuous SmartJoist blocking or two (2) layers of Rimboard		Install continuous SmartJoist blocking	
4. Concentrated loads from jamb studs or posts	In addition to the above, install compression blocks as per Detail F8			

* Or provide bearing as for joists supporting floor loads only, and install continuous SmartJoist blocking, Rimboard or Boundary joist to support roof and wall loads

NOTE:

The Engineered Solution described in this table above considers vertical gravity loads only, and does **NOT** involve a calculation to determine whether the number and type of blocking selected to satisfy the vertical gravity load resistance will necessarily provide sufficient resistance to the lateral loads described as acting on the joists as shown opposite.

Section 8 of AS 1684.2—2010 (a simplified version in AS 1684.4—2010) is used to calculate the lateral wind forces to be transmitted through the floor.

Suitable details must be prepared by a engineer experienced in timber design and detailing that will effectively transfer the lateral loads through the floor system to the nominated ground floor bracing walls.

Full blocking using SmartJoist or SmartRim with the required fixing is a practical and easily installed option.

Mid span blocking

SmartJoists designed and constructed as per this Design Guide and installed with a direct fix ceiling do not require mid-span blocking.

Experience has shown that in rare cases there are some scenarios where properly installed joist bridging elements may be beneficial:

1. Subfloors where there is no lining to the underside of the joists

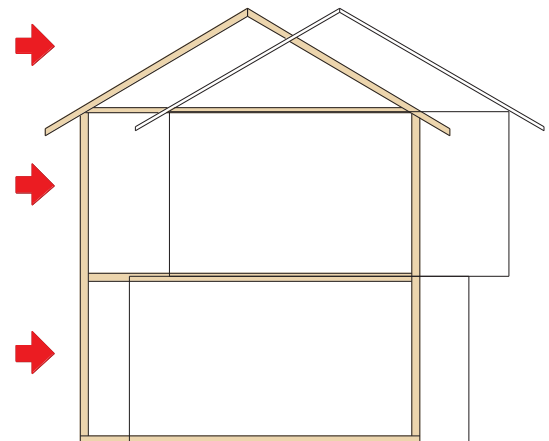

2. Suspended ceiling plaster systems that provide limited lateral support to the lower flange of the SmartJoists
3. Floor systems involving metal fixed plaster systems where normal live load deflections may cause metal to metal noise

For further information on this topic or details of recommended SmartJoist bridging elements, contact the tech support helpline on 1300 668 690

SmartJoist/SmartRim[®] Characteristic blocking capacities

SmartRim[®]

SmartRim rimboard is an alternative solution to blocking with SmartJoists (either long length of cut to length) to support vertical and lateral wall loads as part of a floor or roof framing system.

SmartRim is a 19 or 21 mm LVL (2 veneers are cross laminated for stability) and is sold in 3.6 m lengths, precision ripped to match the height of the SmartJoist range up to and including 360 mm. (400 mm SmartRim in QLD only). Fixing of rimboard is described in detail in SmartJoists - GENERAL INFORMATION item 3 on page 9 of this Design Guide.

SmartRim has a joint strength group of JD4 on the wide face for nails, screws and bolts.

SmartJoist/SmartRim Characteristic capacity (see notes below)		
Vertical load capacity (kN/m) ^{(1) (2)}		Horizontal load transfer capacity (kN/m) ^{(3) (4)}
SmartJoist	SmartRim	
29	21	6.9

- Vertical load capacity above is for instantaneous load conditions and must be multiplied by the appropriate k_1 factor for load condition under consideration
- Vertical load capacity above already includes the k_{12} factor for up to 400 mm depth as per clause I2.3 of AS 1720.1
- Horizontal load capacity above is an instantaneous load condition, with the k_1 for lateral bracing loads usually 1.0
- The above horizontal load capacity is limited by the fixing of the SmartJoist / SmartRim to the frame and can ONLY be achieved if the fixing detail on page 9 of this SmartJoist Design Guide is strictly adhered to.

Penetrations within SmartJoist and SmartRim blocking

The maximum allowable hole size for a SmartJoist/SmartRim shall be $\frac{1}{3}$ of the rim board depth as shown below.

The length of the SmartJoist/SmartRim segment containing a hole shall be at least 8 times the hole size.

SmartJoist hole sizes and corresponding minimum length		
SmartJoist/SmartRim Depth (mm)	Maximum allowable hole size ^{(a) (b)} (mm)	Minimum length of SmartJoist/SmartRim board segment ^(c) for the maximum allowable hole size (mm)
200	130	1050
240	160	1280
300	200	1600
360	235	1900
400	265	2100

- These hole provisions do not apply to SmartJoist/SmartRim installed over openings such as doors or windows
- The diameter of the round hole or the longer dimension of the rectangular hole
- The lengths of the SmartJoist/SmartRim segment per wall line. For multiple holes, the minimum length of SmartJoist/SmartRim segment shall be 8 times the sum of all hole sizes

Application Notes

1. Do not cut holes in SmartRim installed over openings, such as doors or windows, where the SmartRim is not fully supported, except that holes of 40 mm or less in size are permitted provided they are positioned at the middle depth and in the middle $\frac{1}{3}$ of the span (see note 5 for minimum hole spacing).

2. Field-cut holes should be vertically centred in SmartRim and at least one hole diameter or 150 mm whichever is less, clear distance away from the end of the wall line. Holes should never be placed such that they interfere with the attachment of the rim board to the ends of the floor joist, or any other code-required nailing.

3. While round holes are preferred, rectangular holes may be used providing the corners are not over-cut. Slightly rounding corners or pre-drilled corners with a 25 mm diameter bit is recommended.

SmartRim over an opening

Do not cut holes in SmartRim over an opening except for holes of 40 mm or less in size (see note 1).

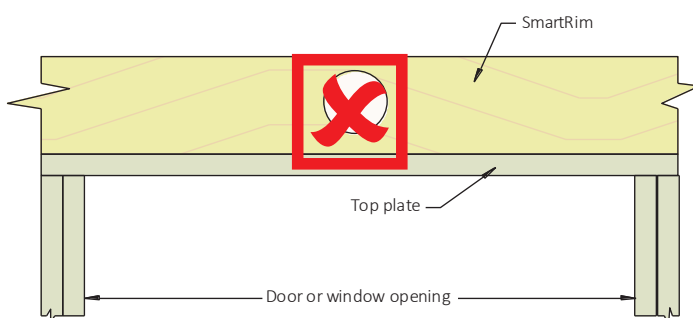

SmartJoist/SmartRim near concentrated vertical load

4. When concentrated loads are present on the SmartJoist/SmartRim (loads not supported by any other vertical-load-carrying members such as squash blocks), holes should not be placed in the SmartJoist/SmartRim within a distance equal to the depth of the SmartJoist/SmartRim from the area of loading.

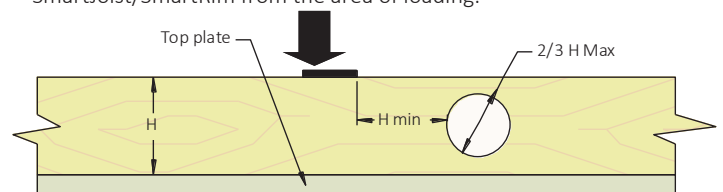

5. For multiple holes, the clear spacing between holes shall be at least two times the diameter of the larger hole, or twice the length of the longest rectangular hole. This minimum hole spacing does not apply to holes of 40 mm or less in diameter, which can be placed anywhere in the rim board (see note 1 for holes over opening) except that the clear distance to the adjacent hole shall be 75 mm minimum.

Multiple holes for SmartJoist/SmartRim

6. All holes shall be cut in a workman-like manner in accordance with the limitations listed above.

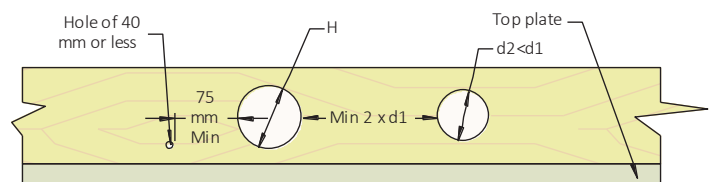

SmartJoist hangers

Joist hanger selection

The joist hangers below have been developed specifically for the flange widths for SmartJoists are manufactured using Z275 light-gauge steel, having zinc coating of 275 gsm (total weight). AS1684.2-2010 and AS1684.3-2010-Australian Standards for Residential Timber Frame Construction stipulates a minimum Z275 steel for all sheet metal products used in an internal environment.

Other joist hangers may be used with SmartJoists but it is the responsibility of the specifier of these alternative joists hangers to ensure that:

- they suit the SmartJoist flange widths and do not require any cutting or packing of the flanges
- they are manufacturer from Z275 light-gauge steel
- they have the adequate capacity for the anticipated end reaction

Fixing of joist hangers

- Hand driven nails** - The joist hangers in the table below are supplied by Tilling Timber as part of a SmartFrame order with the manufacturer recommended nails. All holes are to be filled with the specified nails in order to achieve the stated hanger capacity
- Gun nails** - While the use of gun nails may be common, unless the gun nails are of a minimum 40 x 3.33 diameter, the hanger capacities listed

cannot be assumed

- Screws**—The equivalent number of 35 x 6 gauge bugle-head or wafer-head wood screws may be used in lieu of the supplied nails. Increased capacities can be achieved by using screws. Advice on the capacities of the joist hangers listed below with screws replacing the nails can be obtained by contacting the tech support helpline on 1300 668 690.

Corrosion protection

The standard range of joist hangers made from Z275 light-gauge steel, having zinc coating of 275 gsm is adequate only for INTERNAL applications in most corrosion environments, except areas that are classified as heavy industrial or those subject to high humidity (e.g. enclosed swimming pools) etc. Under these circumstances, seek advice from experts as special protection will be required.

Note: INTERNAL areas are those within the building envelope that are kept permanently dry. In areas outside the building envelope that are exposed to repeated wetting (EXTERNAL areas), stainless steel products or equivalent should be considered. Some alternatives include hot dip galvanised or powder coated steel, which are not Tilling Timber stock items.

For more detailed information contact the tech support helpline on 1300 668 690 or at techsupport@tilling.com.au.

SmartJoist code	Face mount code	Down hanger capacity Φ kN *	No of face nails	Nail size (mm)	Top mount code	Down hanger capacity Φ kN *	No of face nails to support	No of top nails	No of nails to joist	Nail size (mm)
Single joist face mounts					Single joist top mount					
SJ20044	20044F	6.2	8	3.75 x 40	20044T	5.7	2	6	2	3.75 x 40
SJ24040	24040F	7.8	10	3.75 x 40	24040T	5.7	2	6	2	3.75 x 40
SJ24051	24051F	7.8	10	3.75 x 40	24051T	5.7	2	6	2	3.75 x 40
SJ24070	24070F	7.8	10	3.75 x 40	24070T	5.7	2	6	2	3.75 x 40
SJ24090	24090F	7.8	10	3.75 x 40	24090T	5.7	2	6	2	3.75 x 40
SJ25570	25570F	7.8	10	3.75 X 40	N/A					
SJ30040	30040F	9.3	12	3.75 x 40	30040T	5.7	2	6	2	3.75 x 40
SJ30051	30051F	9.3	12	3.75 x 40	30051T	5.7	2	6	2	3.75 x 40
SJ30070	30070F	9.3	12	3.75 x 40	30070T	5.7	2	6	2	3.75 x 40
SJ30090	30090F	9.3	12	3.75 x 40	30090T	5.7	2	6	2	3.75 x 40
SJ36058	36058F	10.9	14	3.75 x 40	36058T	5.7	2	6	2	3.75 x 40
SJ36090	36090F	10.9	14	3.75 x 40	36090T	5.7	2	6	2	3.75 x 40
SJ40058	36058F*	10.9	14	3.75 x 40	40058T	5.7	2	6	2	3.75 x 40
SJ40090	40090F	10.9	14	3.75 x 40	40090T	5.7	2	6	2	3.75 x 40
Double joist face mounts					Double joist top mounts					
2/SJ20044	20044DF	6.2	8	3.75 x 40	N/A					
2/SJ24040	N/A				24040DT					
2/SJ24051	24051DF	7.8	10	3.75 x 40	24051DT	5.7	2	6	2	3.75 x 40
2/SJ24070	24070DF	7.8	10	3.75 x 40	24070DT	5.7	2	6	2	3.75 x 40
2/SJ24090	24090DF	7.8	10	3.75x40	N/A					
2/SJ25570	N/A				N/A					
2/SJ30040	N/A				N/A					
2/SJ30051	30051DF	6.2	8	3.75 x 40	30051DT	5.7	2	6	2	3.75 x 40
2/SJ30070	30070DF	9.3	12	3.75 x 40	30070DT	5.7	2	6	2	3.75 x 40
2/SJ30090	30090DF	7.8	10	3.75 x 40	N/A					
2/SJ36058	36058DF	7.8	10	3.75 X 40	36058DT	5.7	2	6	2	3.75 x 40
2/SJ36090	36090DF	7.8	10	3.75 X 40	N/A	5.7	2	6	2	3.75 x 40
2/SJ40058	36058DF*	7.8	10	3.75 X 40	N/A					
2/SJ40090	40090DF*	7.8	10	3.75 X 40	N/A					

* Requires web stiffeners as per Table on Page 22

SmartJoist hangers

Specialised joist hangers

A range of more specialised joist hangers are available from Tilling Timber, some will be stock items and others will require a lead time before they could be supplied.

Specifiers of these more specialised brackets should contact Tilling Timber during the design phase of the project to ascertain:

1. What brackets are available that would best suit the proposed application
2. The lead time before selected joist hangers could be supplied
3. Whether SmartFrame engineers are required to design individual member connections.

Example specialised brackets/connectors

Internal Flange Hangers - A range of internal flange hanger is available to suit 'L' shape connections and the edge joist in SmartJoist cassette floors

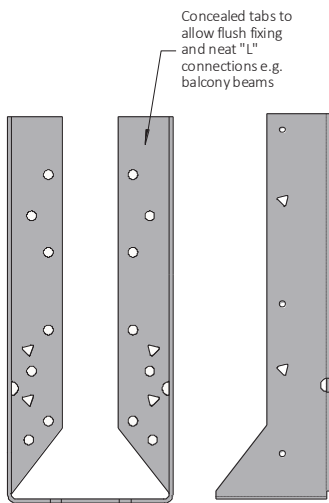

SmartJoist rafter brackets - Access is available to a range of rafter brackets especially designed to make use of the exceptional strength to weight ratio of SmartJoists and apply it to roof member applications. Rafter brackets available include:

1. Variable slope rafter connectors
2. Variable slope and skew rafter connectors
3. Variable ridge connectors

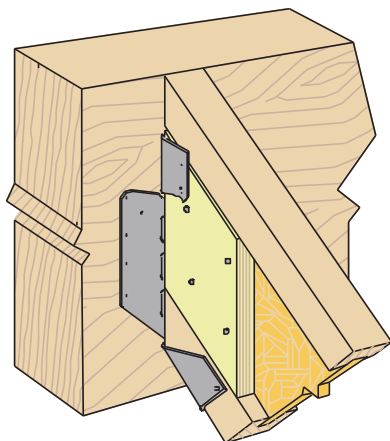

Heavy duty roof beam supports - Tilling Timber has access to a range of heavy duty support brackets for all applications including brackets especially designed to cater for supported beam at a wide range of angles.

An example is the Pryda® BBT125240 shown below

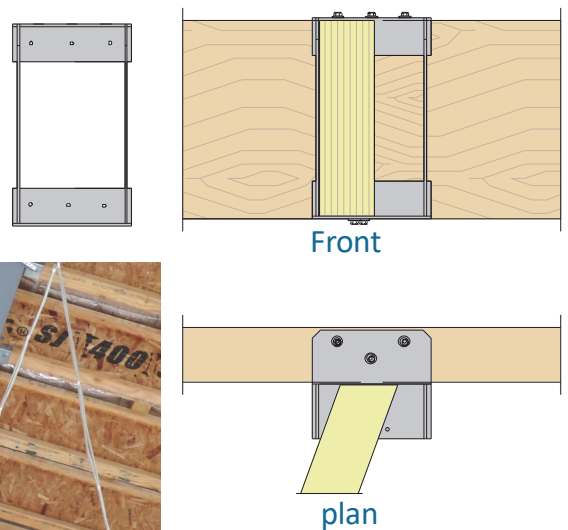

Individual designs - There are occasions where a generic off the shelf bracket is available for a particular application.

In certain circumstances, Smart-Frame engineers may be available to provide individual designs on a fee for service basis for users of SmartFrame product. (conditions apply)

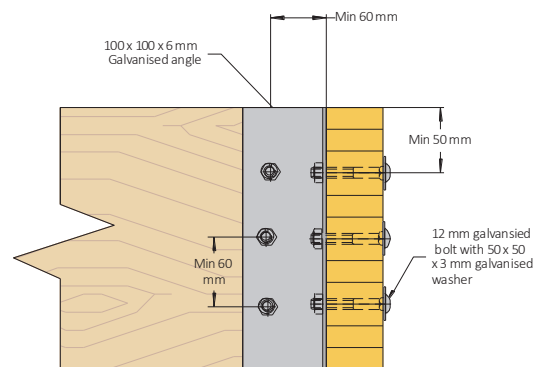

For more detailed information contact the tech support helpline on 1300 668 690 or at techsupport@tilling.com.au.

Oblique connection options

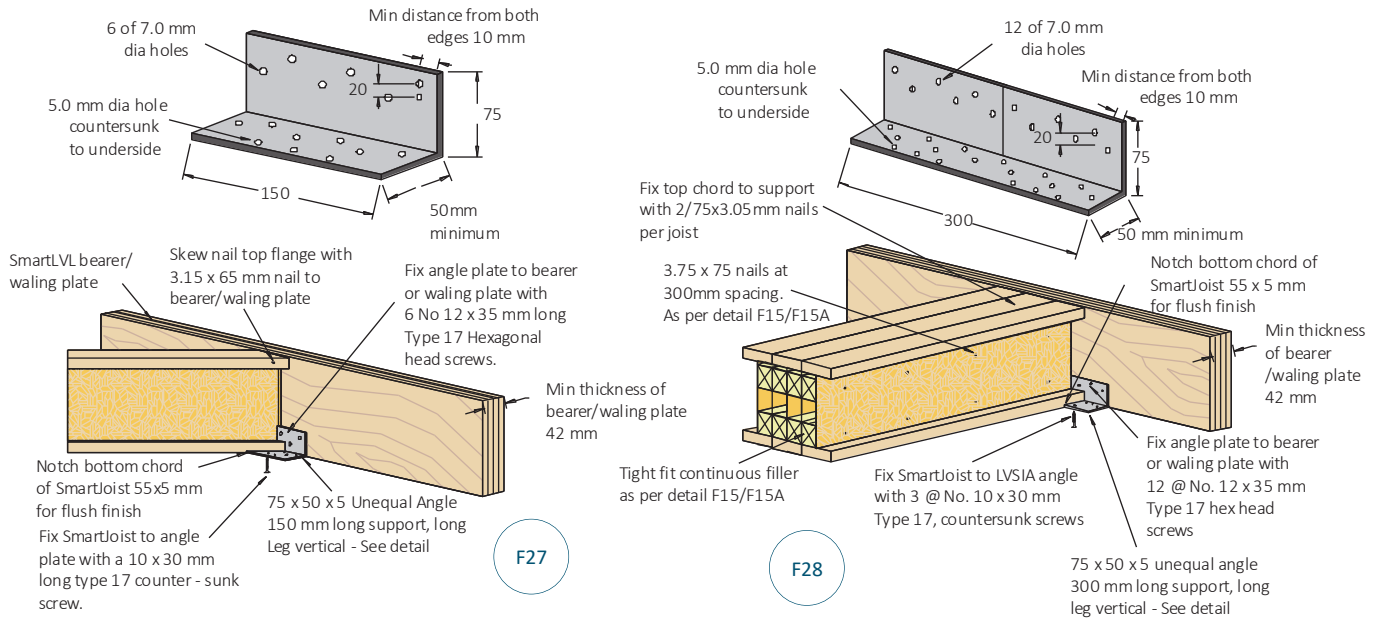

Combination of hangers to add resistance to uplift

Web-Stiffener (grain vertical) on both sides as per detail F13

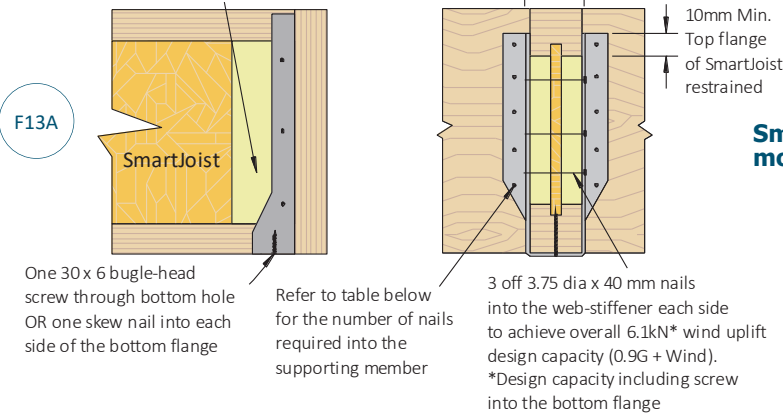

SmartJoist to solid timber/SmartLVL/GLT using face mount hanger combined with web stiffener

Face mount hanger code	No of nails or (screws) into the supporting member
200F	8/3.75 \varnothing x 35 nails (6/12g x 35 screws)
240F	10/3.75 \varnothing x 35 nails (6/12g x 35 screws)
300F	12/3.75 \varnothing x 35 nails (8/12g x 35 screws)
360F	14/3.75 \varnothing x 35 nails (8/12g x 35 screws)
400F	16/3.75 \varnothing x 35 nails (10/12g x 35 screws)

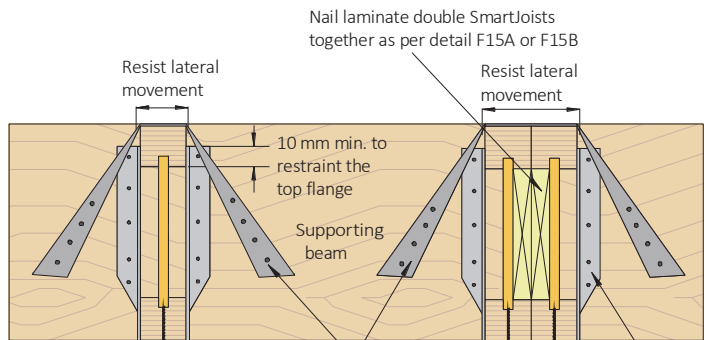

One 30 x 6 gauge bugle-head screw through bottom hole OR one skew nail into each side of the bottom flange

30 x 0.8 mm strap with 4 off 3.15 \varnothing x 35 mm nails each end to increase the wind uplift capacity to 7 kN

Refer to table below for the number of nails required into the supporting member

Face mount hanger code	No of nails or (screws) into the supporting member
200F	8/3.75 \varnothing x 35 nails (6/12g x 35 screws)
240F	10/3.75 \varnothing x 35 nails (6/12g x 35 screws)
300F	12/3.75 \varnothing x 35 nails (8/12g x 35 screws)
360F	14/3.75 \varnothing x 35 nails (8/12g x 35 screws)
400F	16/3.75 \varnothing x 35 nails (10/12g x 35 screws)

SmartJoist to solid timber, SmartLVL/GLT using face mount hanger combined with G.I. straps

General connector installation details

Positive angle nailing



Top mount hangers

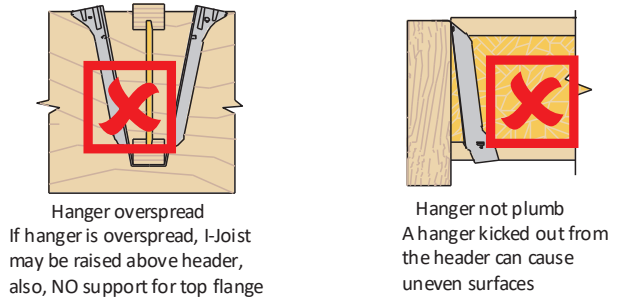

Prevent rotation

Hangers provide some joist rotation resistance; however, additional lateral restraint may be required for deep joists.

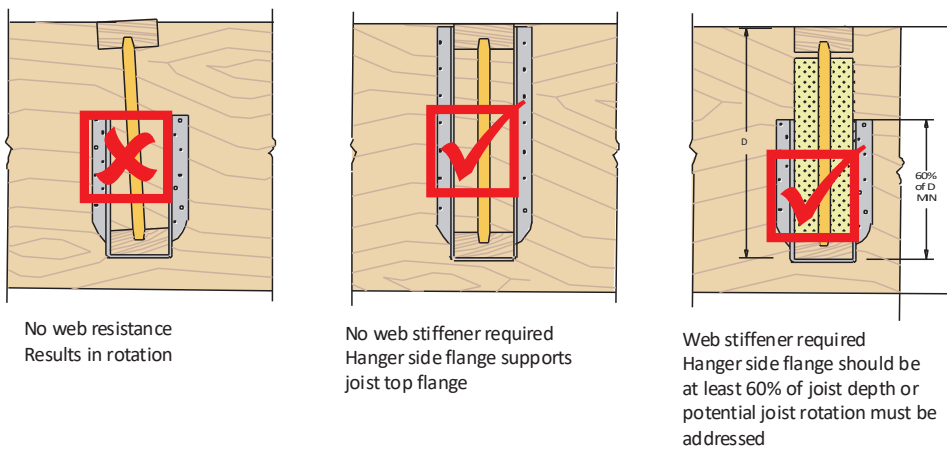

Correct fasteners



Bracket capacities are based upon using the correct bracket nail as per the table on page 11. Bracket nails have special heads to provide strength. Clouts, brads etc. are NOT suitable as bracket nails

SmartJoist headers

Backer blocking each side, hanger nails must extend past the supporting joist's web member into the backer blocking.

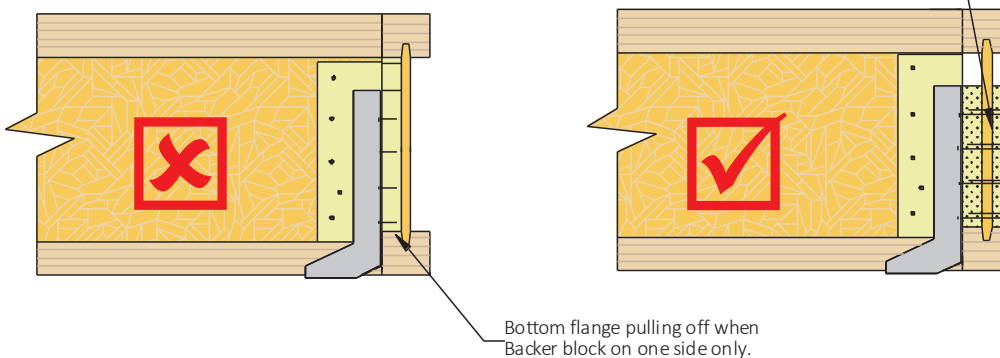

The top flange of the supporting joist must be supported by backer blocks to prevent cross grain bending and rotation.

Top mount connection

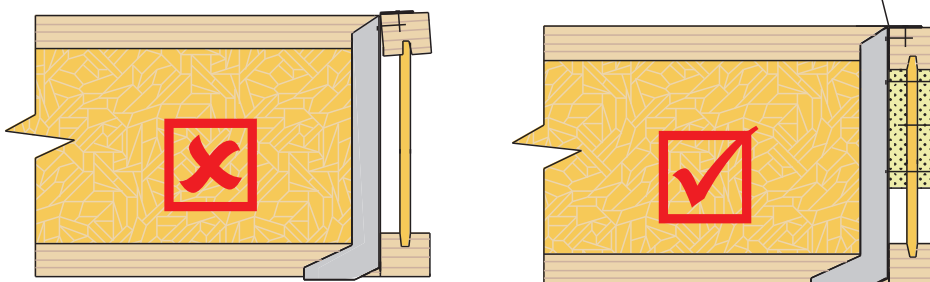

Field repair to damaged SmartJoists

Don't make holes with a hammer other than tapping out pre-punched knockouts

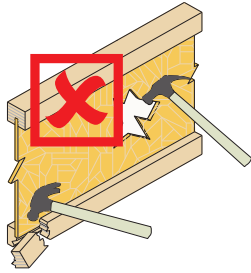

Don't hammer on flanges and damage joist

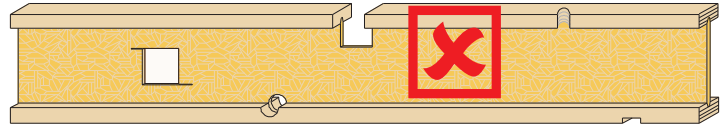

Do not cut or notch flanges
Do not overcut holes in web

SmartJoists are sophisticated Engineered Timber products, and must be treated accordingly. Damage to key components, while affecting only a small percentage of the cross section may be sufficient to render the SmartJoist unsuitable for the purpose.

It is therefore recommended that damage to joists and the possibility of repair be referred to the tech support helpline on 1300 668 690 or at techsupport@tilling.com.au for advice.

Flange damage

- Flange damage becomes more critical the nearer it is to mid-span or an interior support. Flange damage is less critical in close proximity to an end support.
- How much flange damage is acceptable? A rule of thumb is "if you have to ask, it's too much". A saw kerf that knicks the corner of a flange on one lightly-loaded joist could well be acceptable.
- A joist with unacceptable flange damage cannot be repaired, rather a new joist must be added to take its place. The damaged joist does not have to be removed. Consult SmartJoist and SmartLVL tables to find an acceptable new joist that is shallower than the damaged joist so installation is easier. Consider double and triple joists. If the damaged joist is multi-span, the new joist only needs to go across the span(s) where the damage occurs.
- A single damaged joist can sometimes be trimmed off of adjacent undamaged joists (run a calculation within the SmartFrame software).

Web damage

- Web damage becomes more critical the nearer a support. Web damage is less critical near mid-span.
- Web holes can be too big to repair. A flange-to-flange rectangular hole longer than 450 mm located at mid-span probably warrants a new joist. A 150 mm round hole located right by a support probably warrants a new joist. Consult SmartJoist and SmartLVL tables to find an acceptable new joist that is shallower than the

damaged joist so installation is easier. Consider double and triple joists. If the damaged joist is multi-span, the new joist only needs to go across the span(s) where the damage occurs.

- A single damaged joist can sometimes be trimmed off of adjacent undamaged joists (run a calculation within the SmartFrame software)
- Damage that could be confidently repaired in a single, isolated joist, might be judged too severe to repair if several, adjacent joists are involved
- If several small holes violate the 2x diameter proximity rule, but would fit inside a single acceptable hole, then the group of small holes is OK
- Hole repairs generally require a reinforcement that covers the full depth of the web and extends at least 300 mm past each side of the hole.

Damage report information required

1. In order to design a repair, the SmartFrame engineer will have to know all of the design information that is required to run SmartFrame software.
2. Provide a sketch of the damage showing its size, shape and location on the joist.
3. Indicate whether a pipe, duct, conduit, etc. must remain and be accommodated.
4. Indicate how many adjacent joists are affected in each case.

Field repairs to damaged SmartJoist webs

The SmartFrame system now includes the WebFix® (web reinforcement) developed to be a rapid "repair" to webs where penetrations have been placed at inappropriate locations, penetrations too large or other web damage which diminishes the strength of the member. This repair system is unique to SmartJoist applications.

Tilling Timber is the SOLE Australian distributor of this PATENTED system, which in most cases can be fixed around services that have been installed through the web penetrations.

The WebFix® does need to be designed into each situation by SmartFrame engineers and can ONLY be purchased from Tilling offices after the structural design is completed.

SmartFrame Engineered Solutions WebFix®

The innovative combination of time-saving technologies provides SmartFrame engineers the opportunity to design an in-situ repair of a SmartFrame joist web in most circumstances. This reinforcement is designed on a case-by-case basis to be suitable for the particular web, hole, and if applicable, a detailed repair method is provided, along with an engineering calculation. This service is provided subject to the SmartFrame license conditions, terms and conditions, and may attract a fee for service.

Never attempt to install WebFix® without first consulting the Tilling Design Centre. WebFix® is a patented registered and granted invention and requires consultation and use of a qualified Engineer from Tilling Timber Pty Ltd.

Top loaded SmartJoist - penetration located ≥ 20% joist depth in from support

Top loaded SmartJoist - penetration located closer than 20% joist depth in from support

Terminology

When ordering from SmartFrame, use (1) WebFix bracket as defined below.

Toll Free Call 1300 668 690 www.tilling.com.au

Typical SmartJoist floor framing

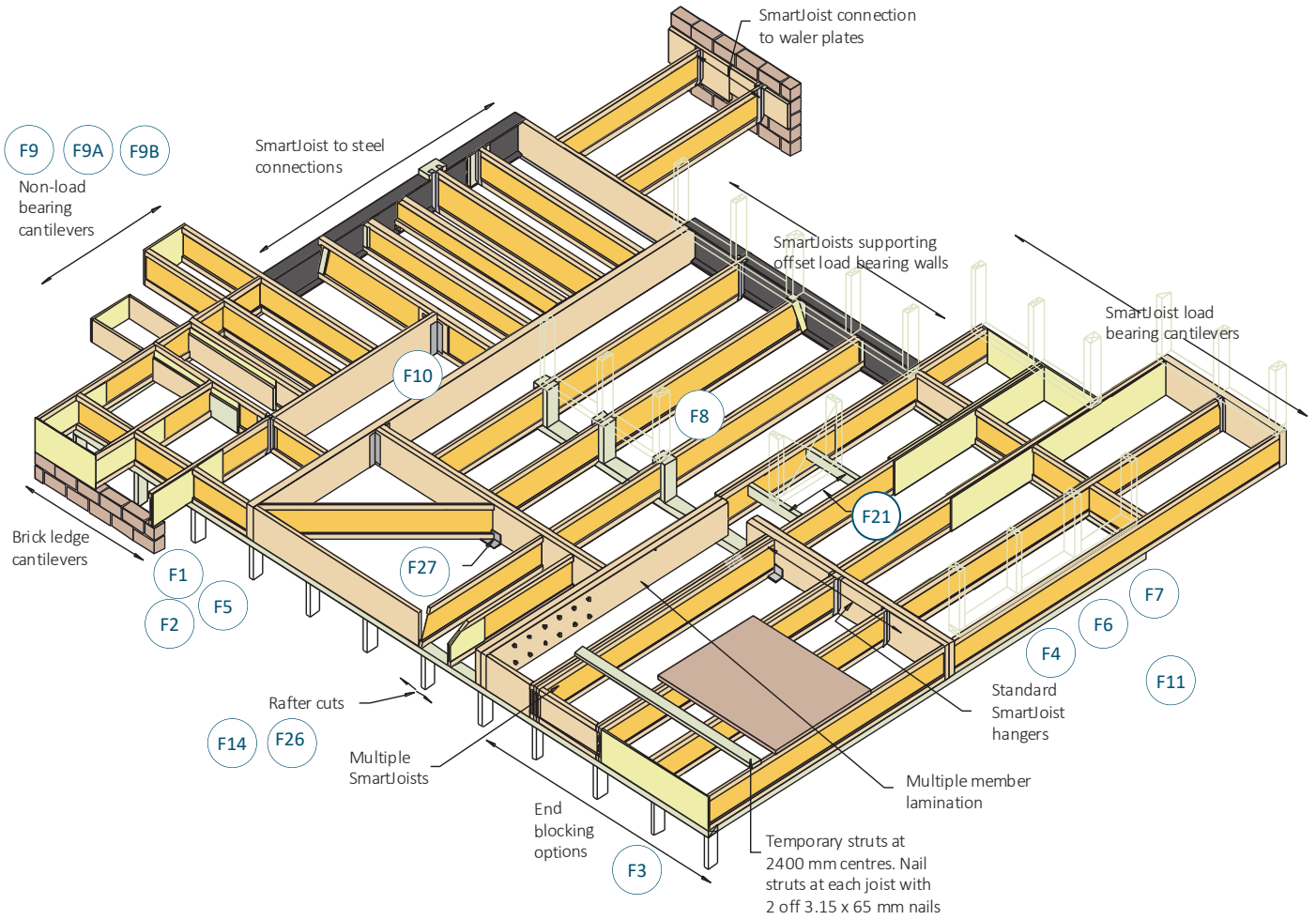

Typical SmartJoist floor construction details

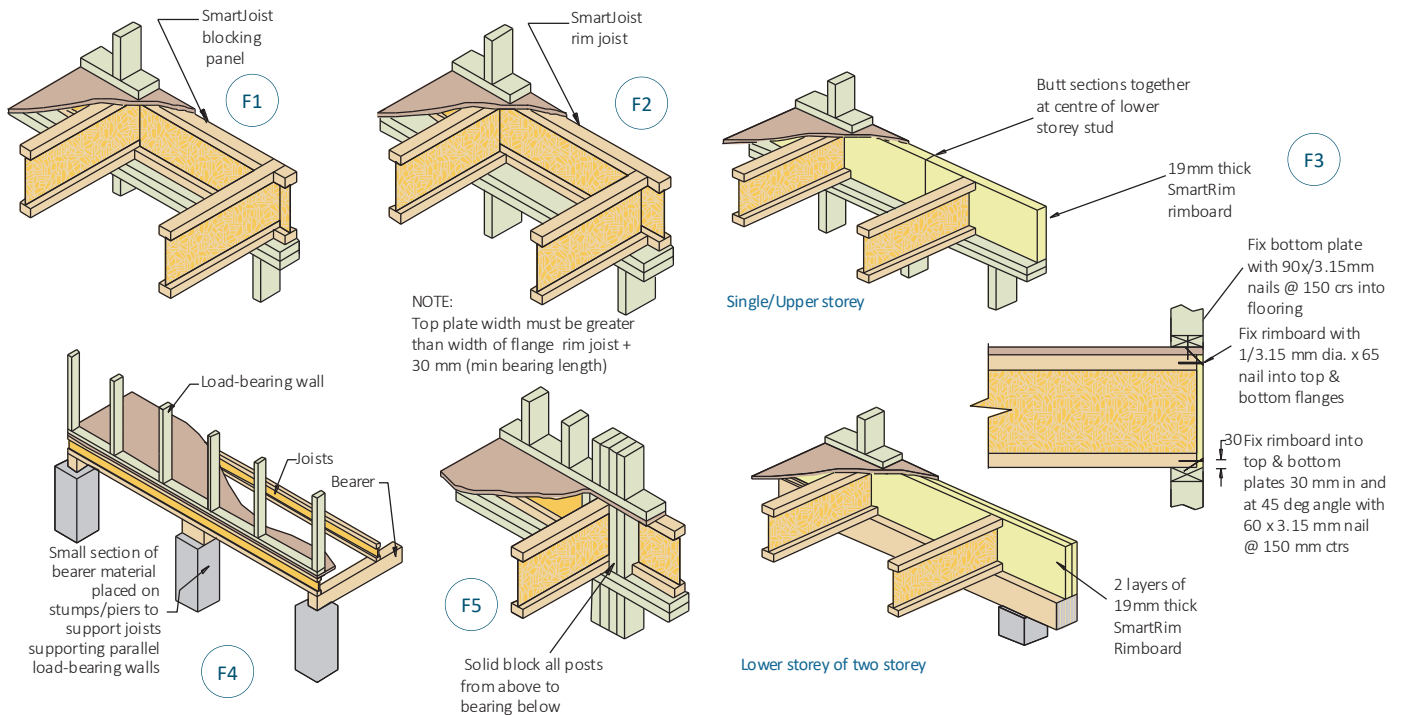

Note:
To achieve the necessary racking resistance through the floor diaphragm, it is important that the nailing provisions of the floor sheeting to the joists as described in AS 1684 (AS 1869 for particle board) be adopted to nail the floor sheeting to the Rim Joist or SmartRim in details F1-F3

Typical SmartJoist floor construction details (cont'd)

F6

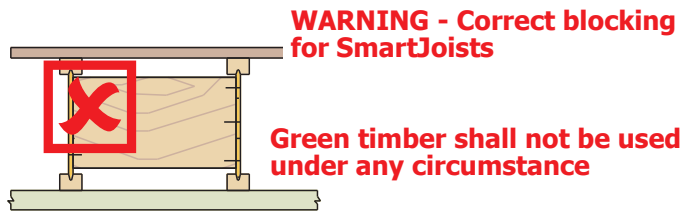
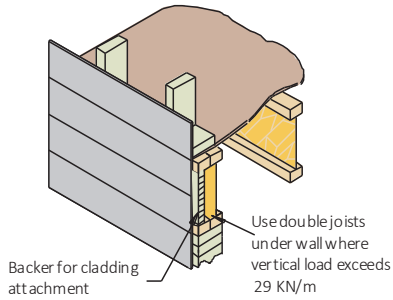

All blocking shall be carried out as per details F1-F3, with blocking to extend to both flanges and skew nailed with 3.15 ϕ x 65 nails, one each side of top and bottom flange.

Interior loading bearing and bracing walls

F7

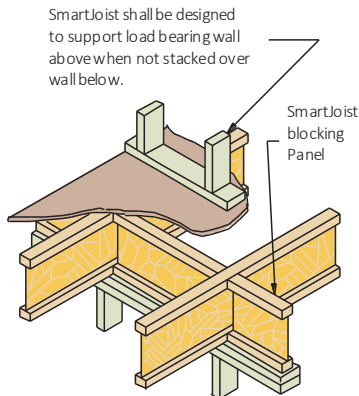

F8

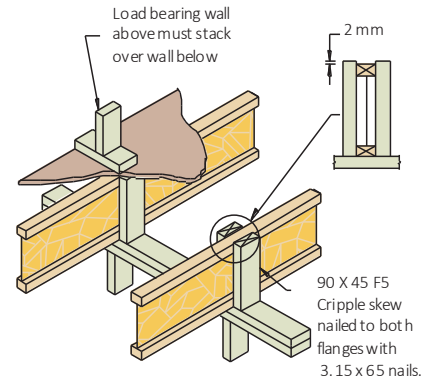

NOTE: Detail F7 with blocking panels is required for bracing walls.

Non load bearing cantilevers (balconies)

Example cantilever spans and minimum back spans for this detail are shown in the table on the next page

1. Adjacent cantilevers joists

F9

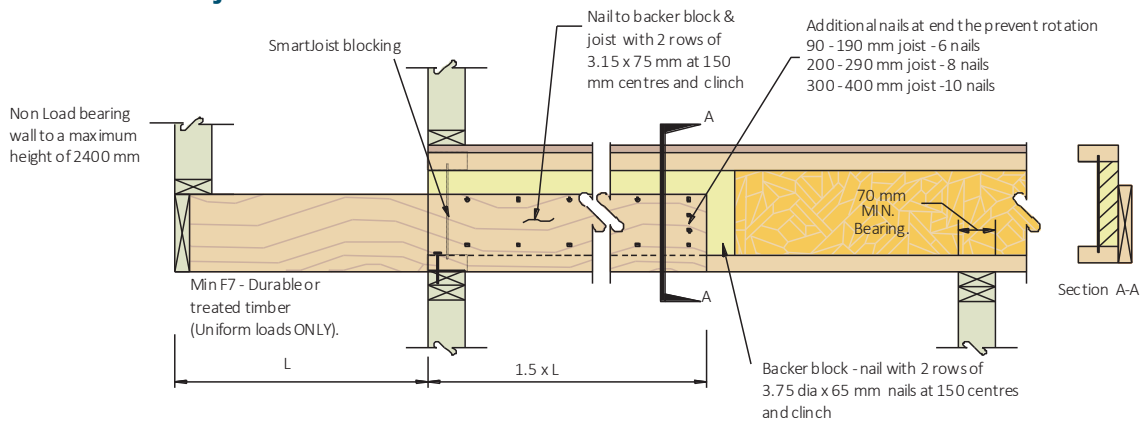

F9a

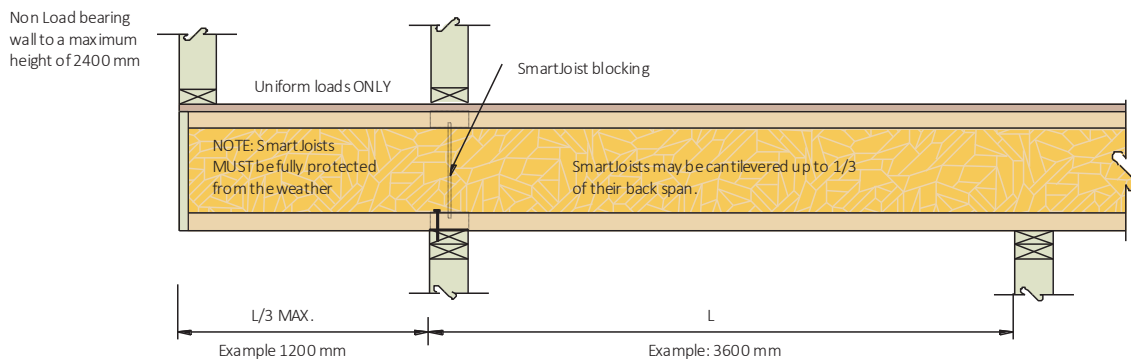

For cantilevered joists supporting load bearing walls see details C1-C4

Cantilevered balconies

2. Nested cantilevers joists

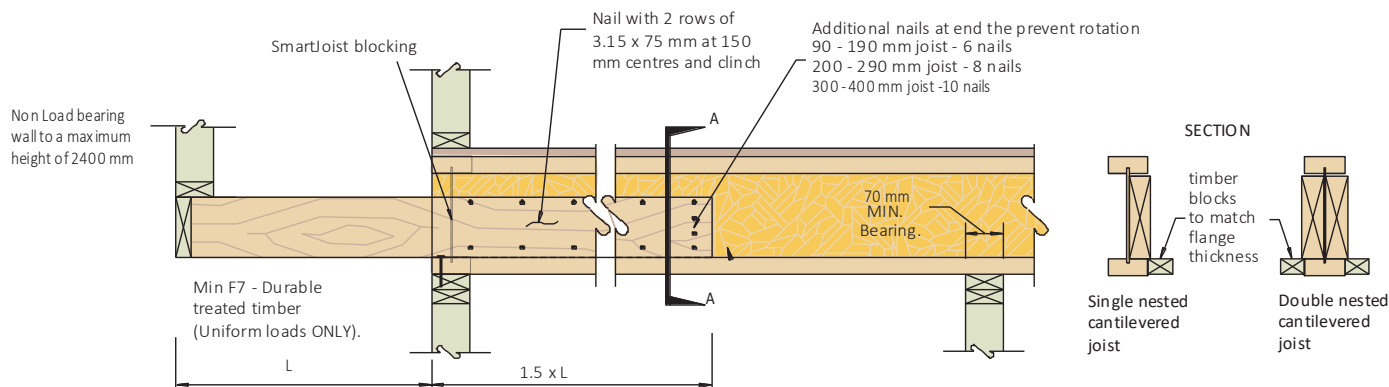

Loadings: Permanent Loading G: self weight + 40 kg/m² + 0.6 kPa of live load permanently applied, live load Q: 2.0 kPa or 1.8 kN point live load, 1.5 kN/m acting at end of cantilever

Cantilever material	Joist spacing (mm)	300		400		450		600	
		Cantilever	Back span	Cantilever	Back span	Cantilever	Back span	Cantilever	Back span
H3 SmartLVL 15	120 x 42	1000	1500	900	1400	900	1400	800	1200
	150 x 42	1300	2000	1200	1800	1100	1700	1000	1500
	170 x 42	1400	2100	1300	2000	1300	2000	1100	1700
	200 x 42	1600	2400	1500	2300	1500	2300	1300	2000
	240 x 42	1900	2900	1800	2700	1700	2600	1600	2400
	300 x 42	2200	3300	2100	3200	2000	3000	1900	2900
	2/120 x 42	1300	2000	1200	1800	1100	1700	1000	1500
	2/150 x 42	1600	2400	1500	2300	1400	2100	1300	2000
	2/170 x 42	1700	2600	1600	2400	1600	2400	1400	2100
	2/200 x 42	2000	3000	1800	2700	1800	2700	1600	2400
	2/240 x 42	2300	3500	2100	3200	2000	3000	1900	2900
2/300 x 42	2700	4100	2500	3800	2400	3600	2200	3300	
H3 MGP 10	120 x 42	900	1400	800	1200	800	1200	700	1100
	140 x 45	1100	1700	1000	1500	900	1400	800	1200
	190 x 45	1400	2100	1300	2000	1300	2000	1100	1700
	240 x 45	1700	2600	1600	2400	1600	2400	1400	2100
	2/120 x 42	1100	1700	1000	1500	1000	1500	900	1400
	2/140 x 45	1300	2000	1200	1800	1200	1800	1100	1700
	2/190 x 45	1700	2600	1600	2400	1600	2400	1400	2100
2/240 x 45	2100	3200	1900	2900	1900	2900	1700	2600	

Backer and filler blocks

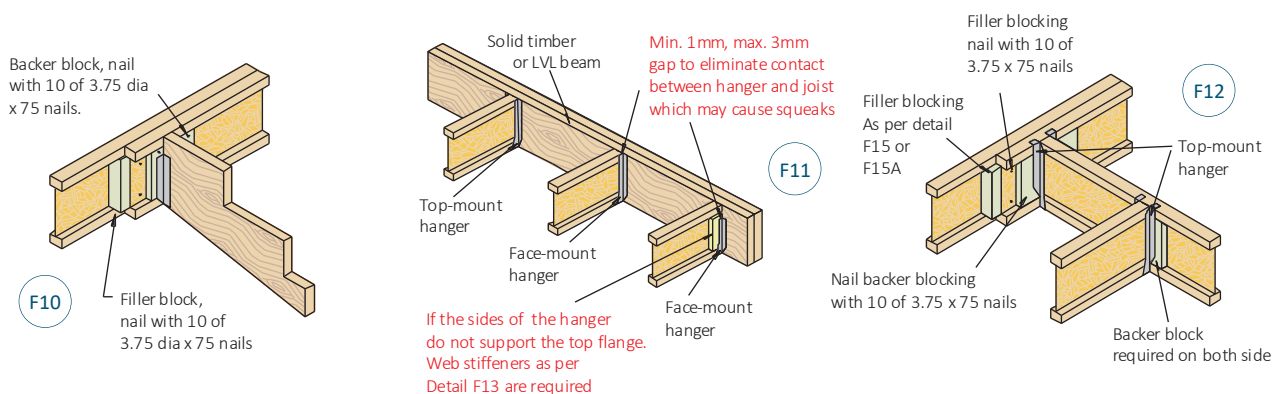

Backer and filler blocks (cont'd)

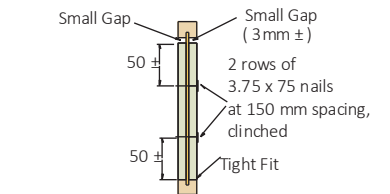
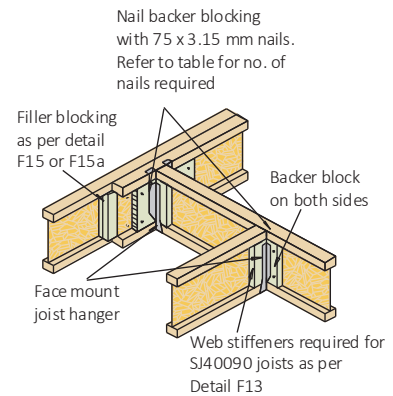
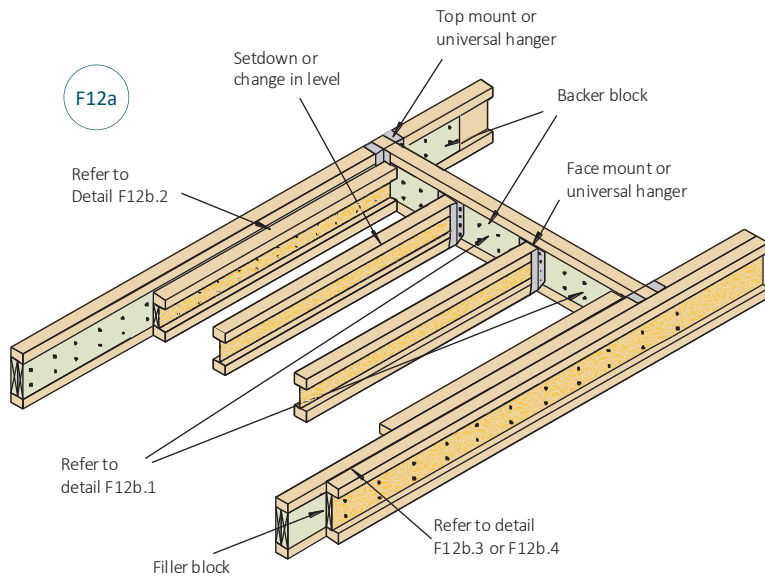

F12b.1

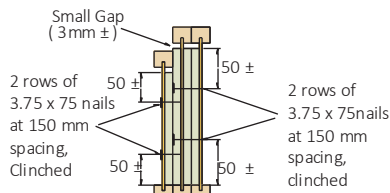

F12b.3

For 2/51mm 2/70mm 2/90mm & 3/SJs with 1/setdown joist attached

F12b

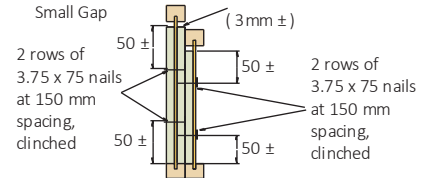

F12b.2

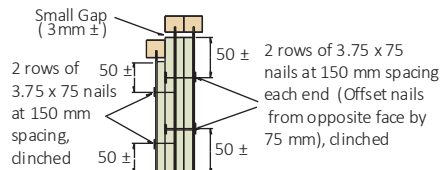

F12b.4

For 2/40mm & 2/44mm SJs with 1/setdown joist attached

Recommended filler blocks and web stiffeners

SmartJoist code	Recommended filler block	Web stiffener material	
		stiffener	nails
SJ20044	120 x 35	15 x 60 mm ply	4-3.15 x 65
SJ24040	140 x 35	15 x 60 mm ply	4-3.15 x 65
SJ24051	140 x 45	19 x 60 mm ply	4-3.15 x 65
SJ24070	150 x 58 LVL	2/15 x 60 mm ply	4-3.15 x 65
SJ24090	2/140 x 45	2/19 x 60 mm ply	5-3.15 x 65
SJ25570	170 x 58 LVL	2/15 x 60 mm ply	4-3.15 x 65
SJ30040	190 x 35	15 x 60 mm ply	4-3.15 x 65
SJ30051	190 x 45	19 x 60 mm ply	4-3.15 x 65
SJ30070	150 x 58 LVL	2/15 x 60 mm ply	4-3.15 x 65
SJ30090	2/190 x 42 LVL	2/19 x 60 mm ply	5-3.15 x 65
SJ36058	250 x 50	2/12 x 60 mm ply	5-3.15 x 65
SJ36090	2/240 x 45	2/19 x 60 mm ply	5-3.15 x 65
SJ40058	250 x 50	2/12 x 60 ply	5-3.15 x 65
SJ40090	2/240 x 45	2/ 19 x 60 mm ply	5-3.15 x 65

NOTES:

1. Use plywood sheathing for web stiffener with face grain parallel to long axis of the stiffener
2. Filler blocks noted are for the general requirements of the details within this Design Guide
3. Leave 3 mm gap between top of filler blocks and bottom of top flange.

Concentrated loads on SmartJoists

Web stiffeners under concentrated loads are required as shown below for concentrated loads that exceed 6.5 kN ONLY.

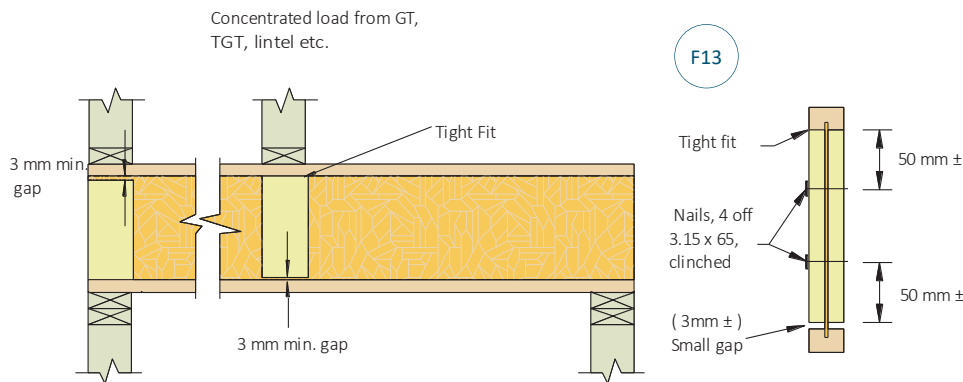

NOTE:

1. Web stiffeners are NOT required at end bearing supports when span length are taken from the SmartJoist Design Guide, except where they are required to prevent rotation if the joist hanger does not laterally restrain the top flange
2. Web stiffeners may be required at inner supports under concentrated loads. Consult the appropriate tables.

Multiple SmartJoist members

(a) filler blocks

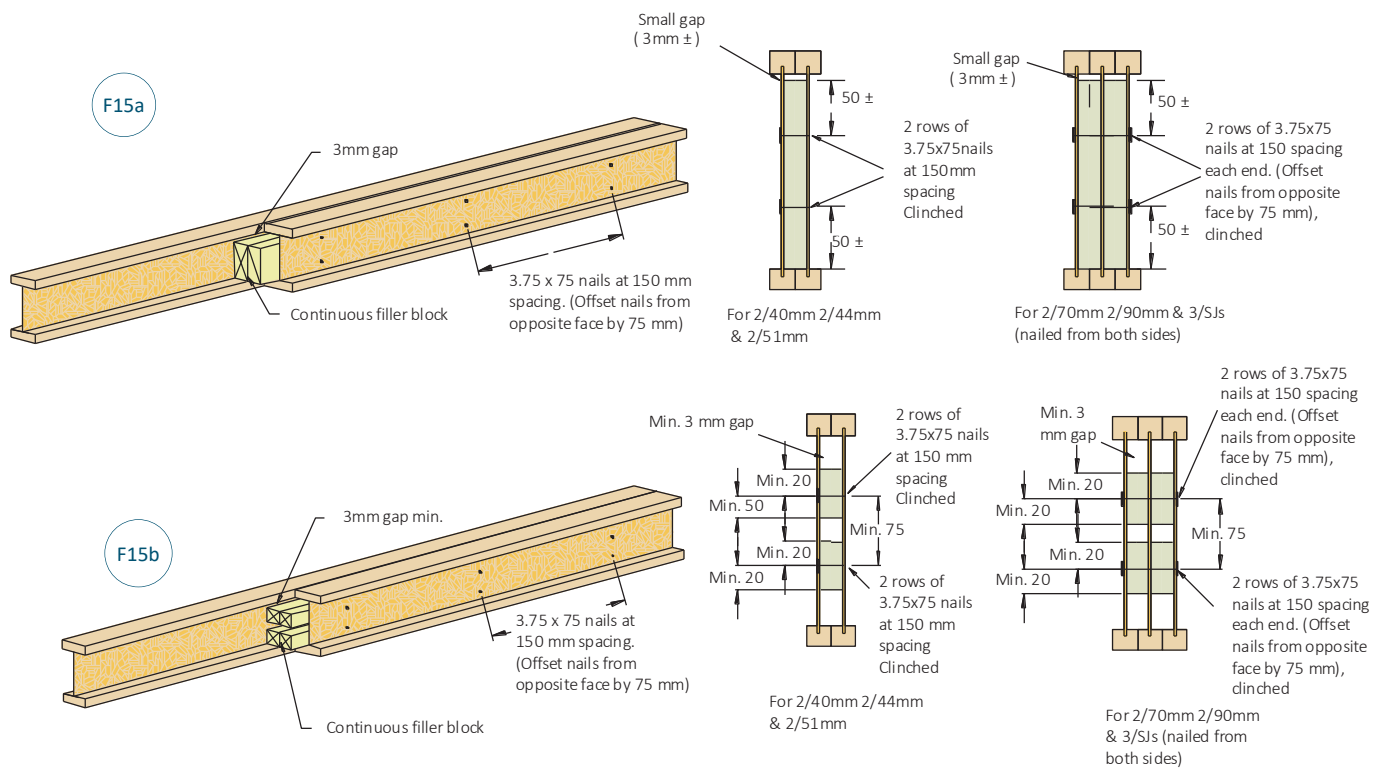

(b) SmartJoist Multi Joist clips (MJC)

The SmartFrame MJC is Australia's first backer and filler free solution to join multiple SmartJoist members.

2 ply SmartJoist supporting concentrated loads

SmartJoist Applications - Characteristic Concentrated loads (kN)	
No of MJC's	Max incoming Concentrated Load
4	16.4
8	24.6

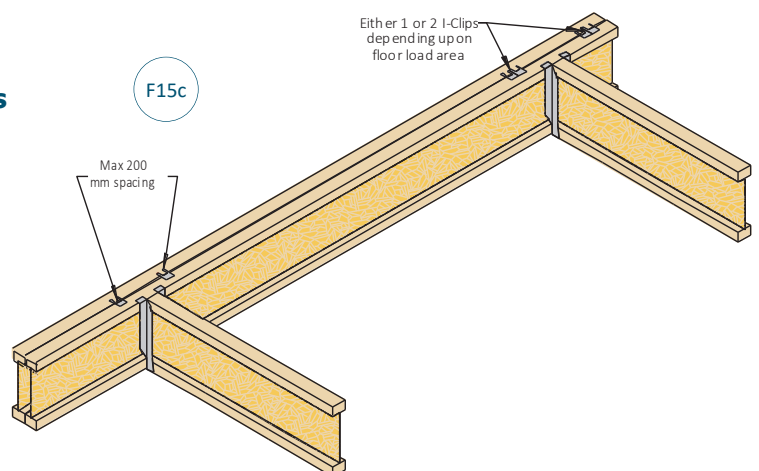

(b) SmartJoist MJC (cont'd)

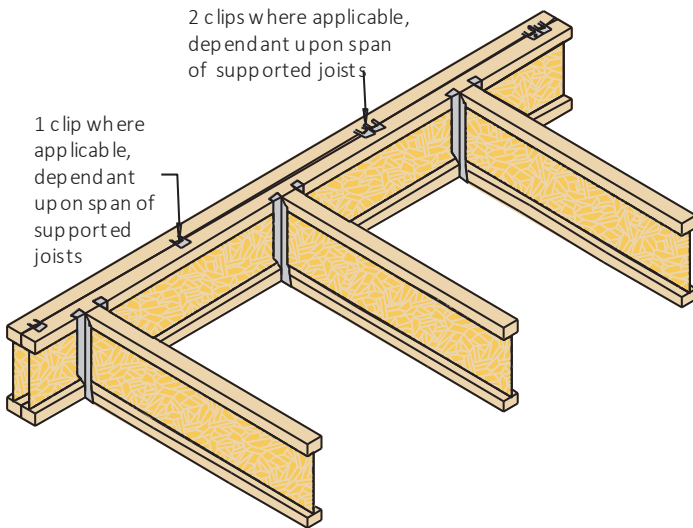

2 ply SmartJoist supporting regular loads

SmartJoist Applications - Characteristic Regular loads (kN)	
No of MJC's	Max incoming regular Load
2	8.2
4	12.3

Limited end notching at supports

The cutting of notches in the ends of joists may reduce the allowable end reactions of the SmartJoists. The amended end reaction capacities of SmartJoists with a 12 mm notch are as follows:

- Without web stiffeners - 80% of allowable end reaction
- With added web stiffeners (as per detail F13) - Full end reaction capacity.

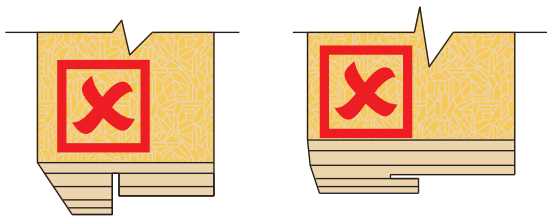

Do not over cut flanges. Substantial reductions in capacity may occur if flanges are over cut.

To maintain the end reaction capacities above, end flange notching is strictly limited to:

1. Notch depths NOT greater than 12 mm
2. Notches cleanly cut - NO over cutting
3. Notch length not to exceed more than 5 mm past the support.

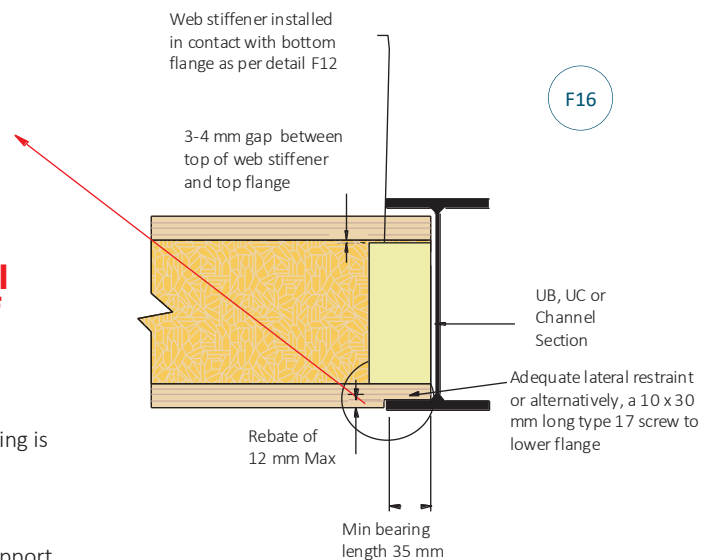

Example fixing of SmartJoists to steel beams

(a) Top mount or universal hangers

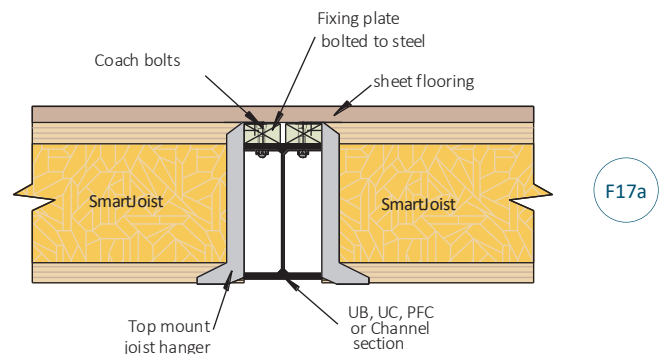
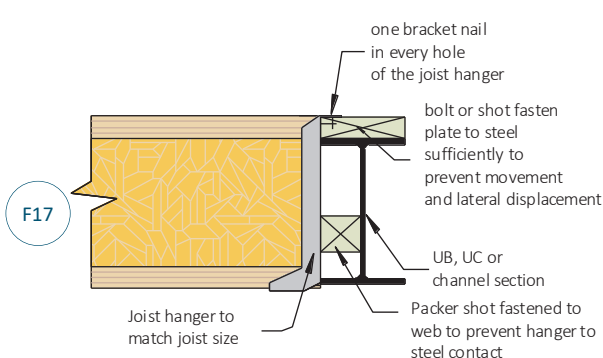

Example fixing of SmartJoists to steel beams

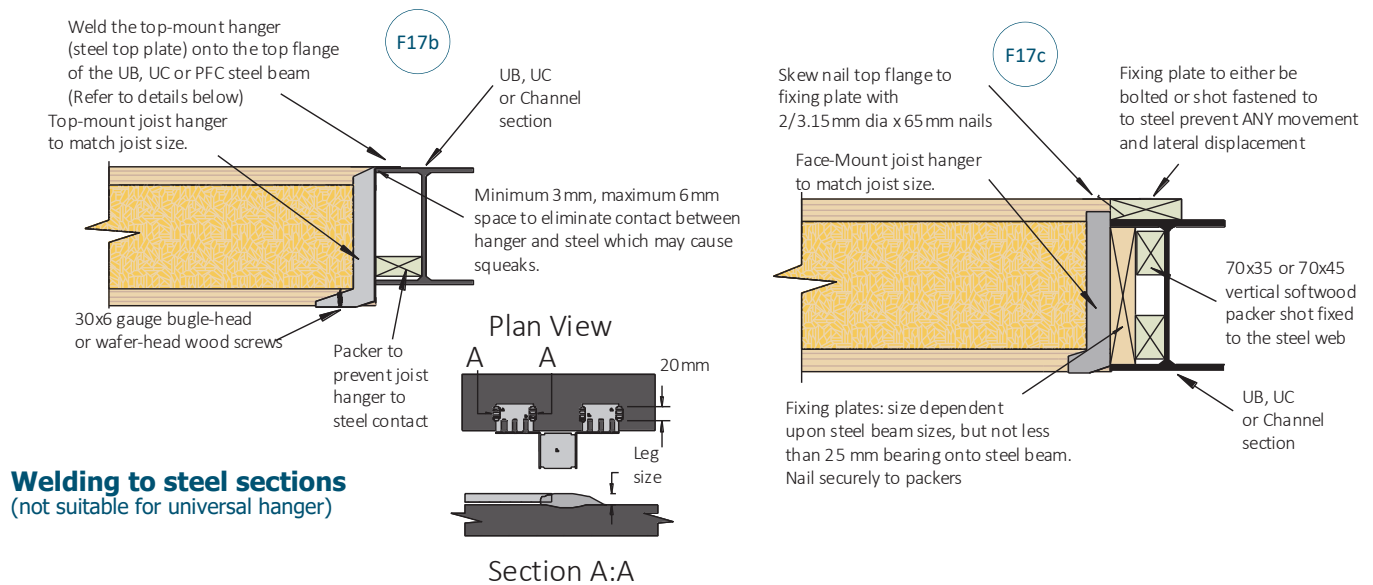

The welding of top mount SmartJoist hangers to common steel sections (UB, UC etc. must be carried out strictly as follows:

1. Supporting steel section must be thoroughly cleaned to remove black scale, rust, paint etc.
2. Clamp top flange of bracket hard up against steel section
3. Apply fillet weld to lap joint with the minimum weld length of 20 mm with a leg size at least the thickness of the metal hanger (see diagram above)
4. Commence weld pool away from the hanger steel to ensure penetration into supporting steel prior to penetration into hanger tab
5. Finish connections with anti-corrosive paint to achieve appropriate corrosion resistance
6. It is essential that welding is conducted under the guidance of an experienced welder.

(b) Rebated into steel beam

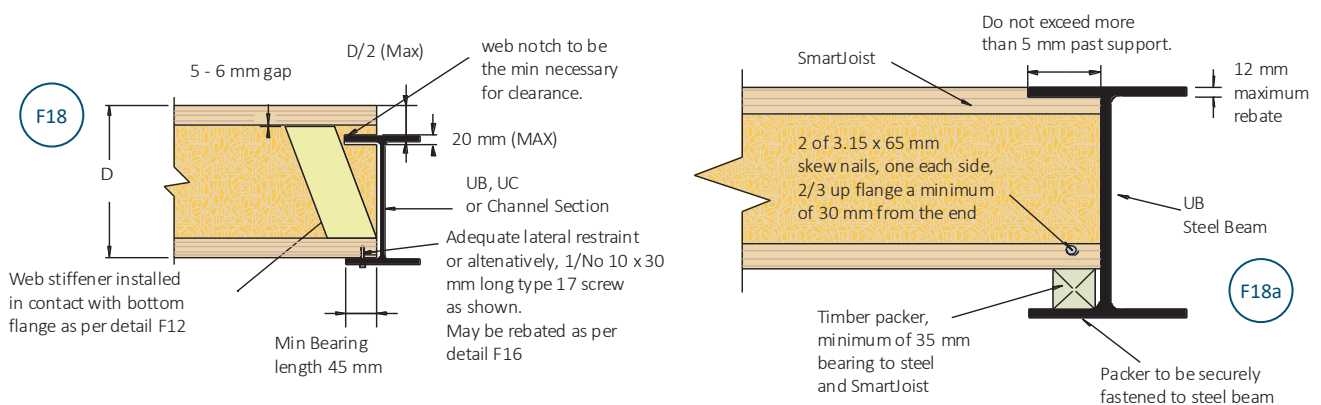

(c) Face mounting to steel

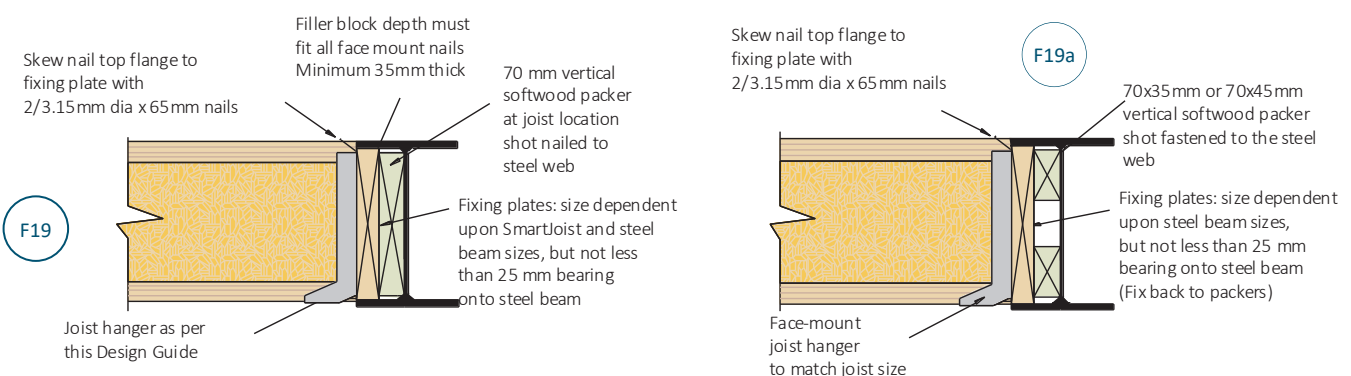

Example fixing of SmartJoists to steel beams (cont'd)

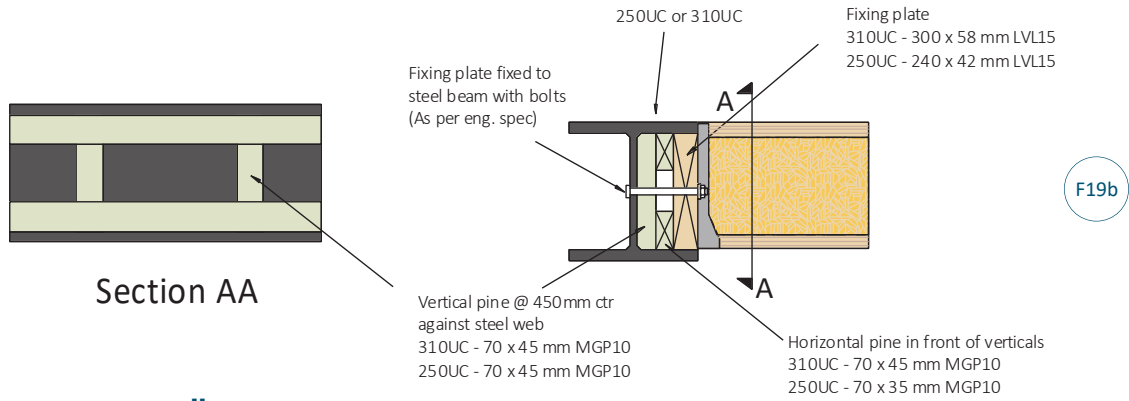

(c) Fixing to masonry walls

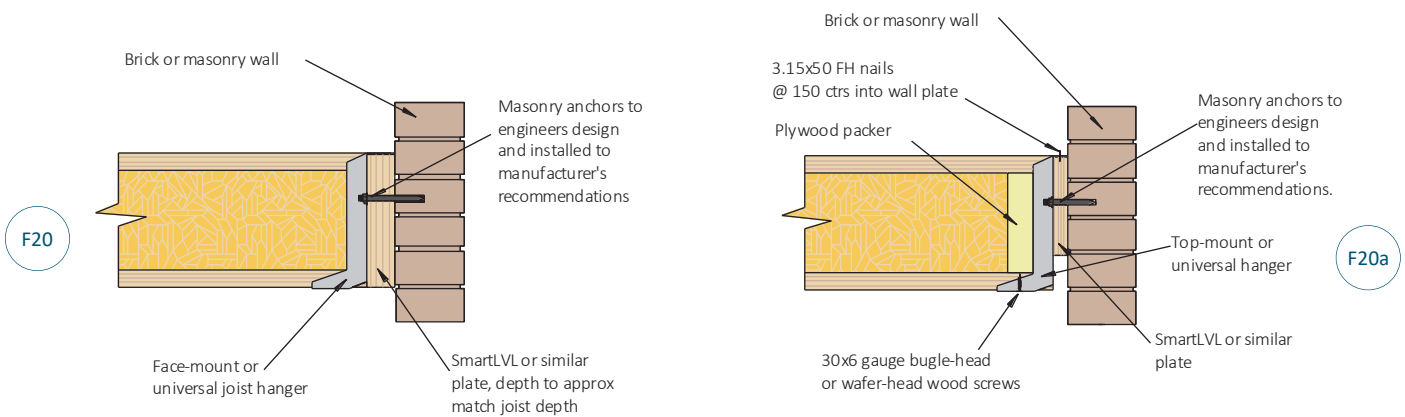

Joist/beam connections supporting offset load bearing walls

Modern building designs frequently call for the upper storey of a two storey dwelling to be set back from the lower wall to allow sufficient light access to all areas of the building. Provided that the SmartJoists have been designed to support this offset load, no special provisions need to be made for their support EXCEPT in the following support conditions:

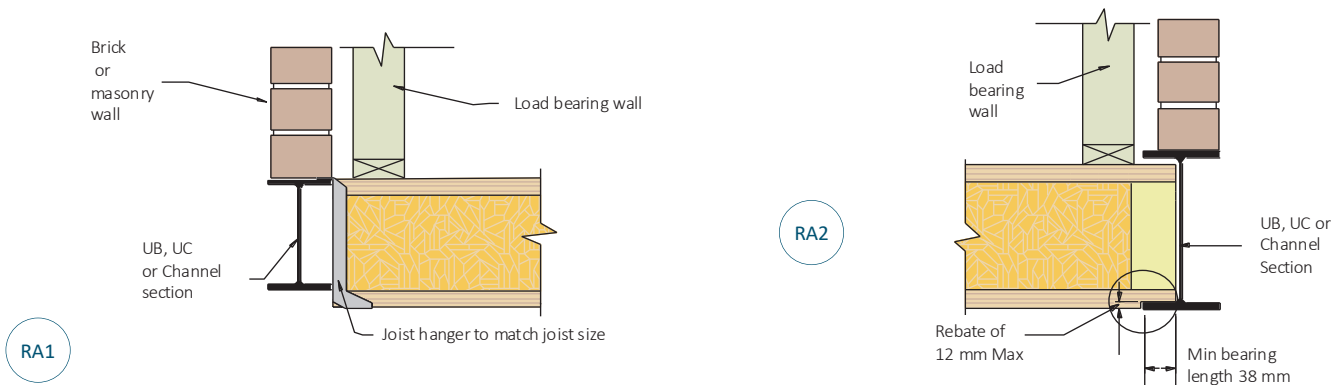

Maximum roof area supported (m²)

- based upon worst case of 40 mm flange width (conservative for wider flanged joists)

Joist spacing (mm)	Joist supported on joist hanger RA1								Lower flange bearing RA2							
	300	400	450	600	300	400	450	600	300	400	450	600	300	400	450	600
Joist span (mm)	Sheet				Tile				Sheet				Tile			
3500	21.7	15.0	12.8	8.2	9.6	6.7	5.7	3.6	6.9	6.4	6.2	5.3	3.1	2.9	2.8	2.4
4000	21.1	14.5	12.3	6.9	9.4	6.4	5.5	3.1	6.7	6.2	6.0	4.6	3.0	2.8	2.7	2.0
4500	20.5	13.9	11.7	5.7	9.1	6.2	5.2	2.5	6.6	6.0	5.7	3.9	2.9	2.7	2.5	1.7
5000	20.0	13.4	10.4	4.4	8.9	5.9	4.6	2.0	6.4	5.8	5.1	3.1	2.9	2.6	2.3	1.4
5500	19.4	12.1	9.1	3.2	8.6	5.4	4.1	1.4	6.3	5.3	4.6	2.4	2.8	2.4	2.0	1.1

Support for Concentrated loads - Joist/beam connection supporting offset load bearing walls

Concentrated loads from any source such as girder trusses MUST be transferred through the floor space WITHOUT adding extra vertical loads to the ends of the SmartJoist at its bearing support.

Examples of transferring these loads are shown below RA3 in-

volves the use of inclined timber struts as shown in the detail opposite. Struts must be a tight fit and at a minimum angle of 60° to the horizontal. RA4 uses a solid member in lieu of SmartJoist under large concentrated loads. RA5 involves a face fixing to blocked out steel beam.

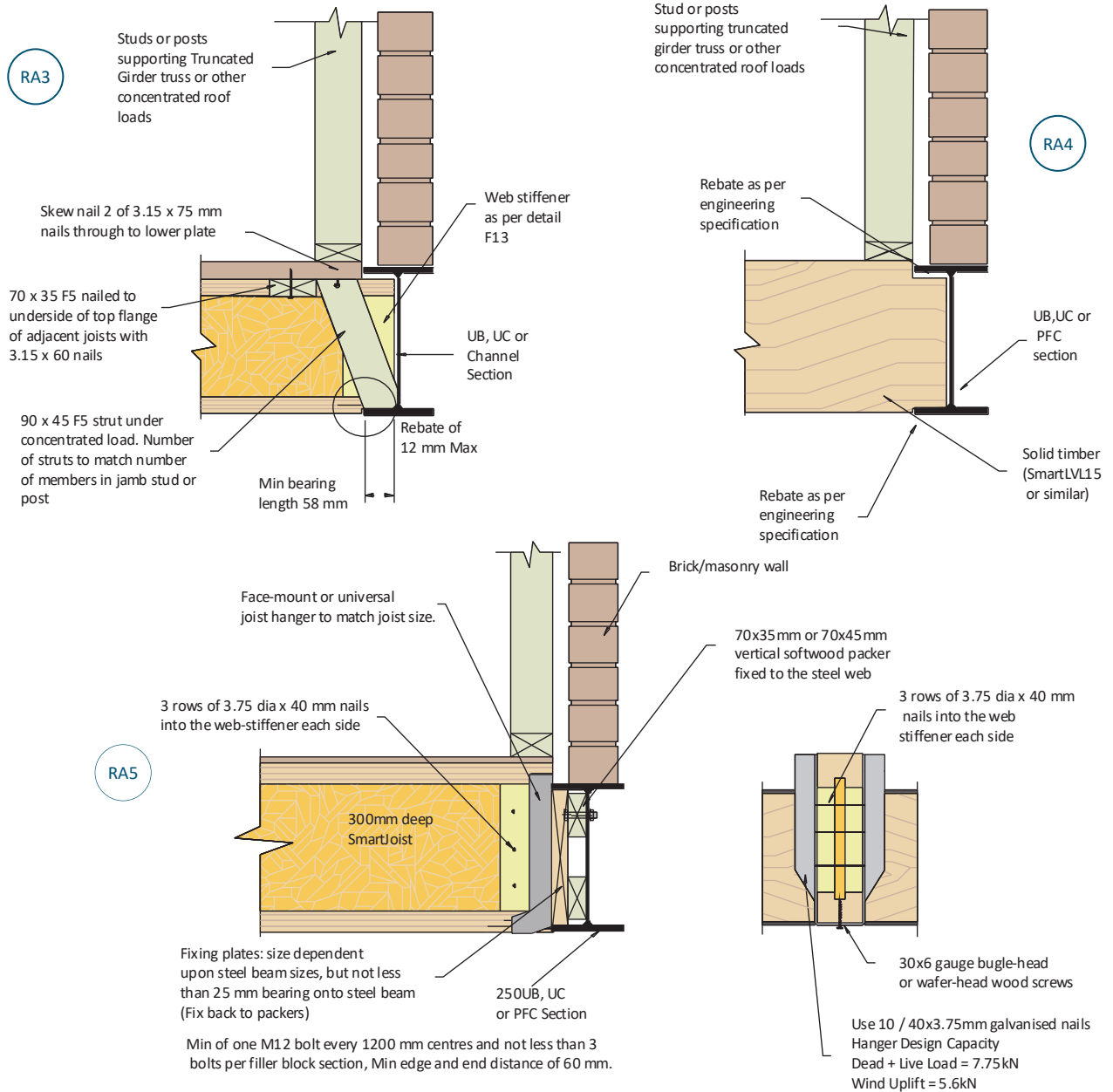

Beams supporting SmartJoists – Multiple member laminations

Vertical laminations may be achieved by adopting the procedures described in clause 2.3 of AS1684, however these procedures should be considered as the minimum requirements to achieve the desired effect.

Experience with SmartLVL beams indicates that this degree of fixing may not satisfactorily prevent cupping of individual components as a result of the ingress of moisture between laminates during construction. The suggested method of vertical lamination below provides a greater level of fixity between individual components, and with the use of an elastomeric adhesive, also prevents moisture penetration between the laminates.

Multiple member laminating of top loaded beams (Symmetrical loading)

The edges of the individual sections must be carefully aligned to each other so that the composite beam is flat, allowing the applied loads to be equally shared.

- Depths up to and including 300 mm: 2 rows of nails as shown above at 300 mm centre
- Depths in excess of 300 mm: 3 rows of nails as shown above at 300 mm centres.

Beams supporting SmartJoists – Multiple member laminations (cont'd)

1. Nailing

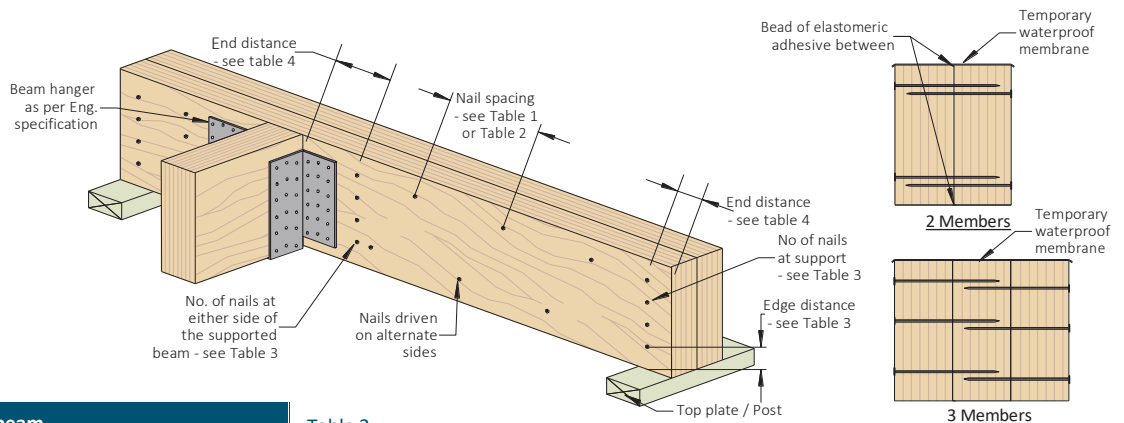

Table 1

Top (symmetrically) loaded beam			
Section width	Nail type	No of nail rows (both sides)	Nail spacing (mm)
2/35	3.15 x 65	2 or 3*	300
3/35 & 2/45	3.30 x 90	2 or 3*	300
2/42	3.06 x 75	2 or 3*	200
3/42, 3/45 & 2/58 3/58, 2/65 & 3/65	Nail lamination is not suitable, requires screws or bolts		

* Beam depth \geq 300 mm 3 rows of nails

Table 3

Beam depth (mm)	Min. number of nails required	
	At support	At either side of supported beam
90–150	3	3
160–300	5	6
> 300	6	8

Table 2

Side (non-symmetrically) loaded beam					
Section width	Nail type	No of nail rows at 300mm ctrs (both sides)	Max. floor joist span supported by outer member (mm)*	No of nail rows at 300mm ctrs (both sides)	Max. floor joist span supported by outer member (mm)*
2/35	3.15 x 65	2	2150	3	3250
3/35	3.30 x 90	2	5100	3	7600
2/45	3.30 x 90	2	2550	3	3800
2/42	3.06 x 75	2	2300	3	3400
3/42 & 3/45	3.30 x 90	2	2550	3	3800
2/58 & 3/58	3.30 x 100	2	2500	3	3800
2/65 & 3/65	3.30 x 100	2	1350	3	2050

* Floor loads $G = 62 \text{ kg/m}^2$, $Q = 1.5 \text{ kPa}$

Table 4

Nail dia. (mm)	Min. edge distance (mm)	Min. end distance (mm)	Min. distance between nails (across the grain) (mm)
3.06 & 3.15	20	70	40
3.30	20	75	45

2. Type 17 screws

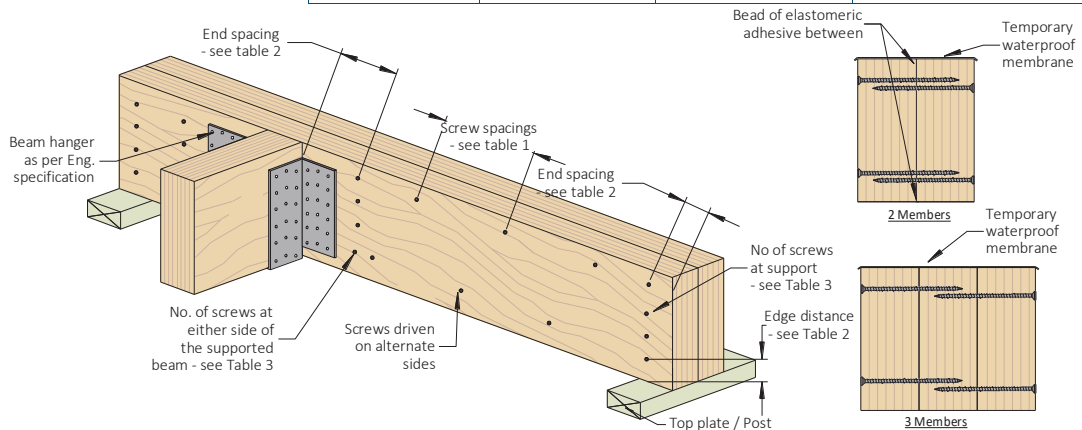

Table 1

Side (non-symmetrically) and top loaded beam				
Section width	Type 17 screw size	No of screw rows (both sides)	Screw spacing (mm)	Max. floor joist span supported by outer member (mm)**
2/35 & 3/35	10g x 65	2 or 3*	200	4500
2/42 & 3/42	12g x 75	2 or 3*	200	5900
2/45 & 3/45	12g x 90	2 or 3*	200	6400
2/58 & 3/58	14g x 100	2 or 3*	200	7100
2/65 & 3/65	14g x 125	2 or 3*	300	6000

* for beam depths \geq 300 mm, use 3 rows of screws

** Floor loads $G = 1.25 \text{ kPa}$, $Q = 2.0 \text{ kPa}$

Table 2

Type 17 screw size	Min. edge distance (mm)	Min. end distance (mm)	Min. distance between screws (across the grain) (mm)
10g	30	50	20
12g	35	60	25
14g	40	70	30

Table 3

Beam depth (mm)	Min. number of screws required	
	At support	At either side of supported beam
90–240	3	3
> 240	4	4

Multiple member lamination

3. Bolts

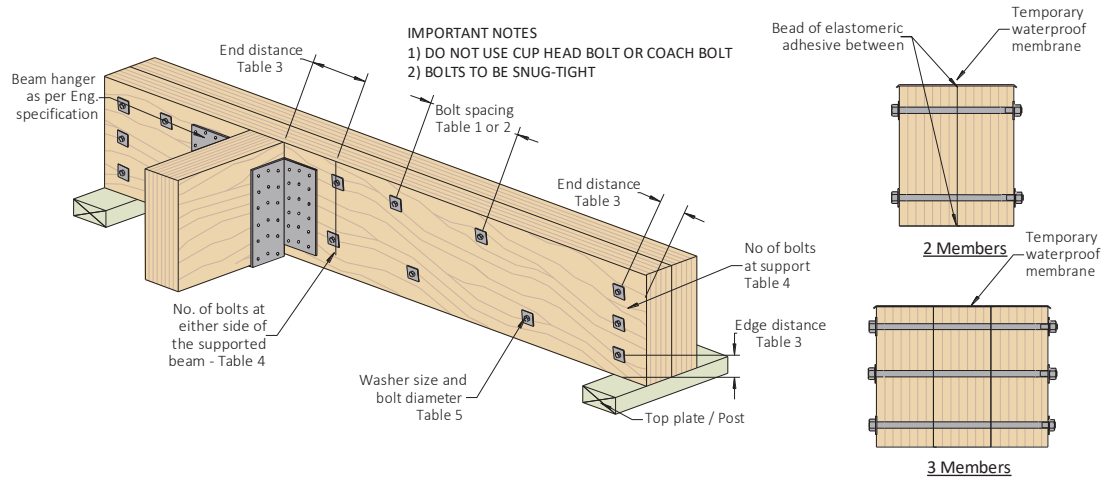

Table 1

Top (symmetrically) loaded beam - M12 Hex head bolt	
Beam depth ≤ 300 mm	Beam depth > 300 mm
2 rows of bolts at 300 mm ctrs	3 rows of bolts at 300 mm ctrs

Table 2

Side (Non symmetrically) loaded beam - M12 Hex head bolt		
Maximum floor joist span supported by the beam mm*		
2 rows at 600 mm ctrs	2 rows at 300 mm ctrs	3 rows at 600 mm ctrs
7200 mm	12,000 mm	10,800 mm

* based upon floor loads of G: 1.25 kPa Q: 2.0 kPa

Table 3

Bolt size	Min. edge distance	Min. end distance	Min. distance between bolts (across grain)
M12 Hex head	60 mm	60 mm	60 mm

Table 4

Beam depth (mm)	Min. number of bolts required	
	At support	At either side of supported beam
90 –150	1	1
160 –240	2	2
> 240	3	3

Table 5

Bolt diameter (mm)	Washer dimensions		
	Thick-ness (mm)	Min. diameter of round washers (mm)	Min. side length of square washers (mm)
M12	3	55	50

Rafter cuts for SmartJoist floor joists

SmartJoists can be “rafter cut” but only within the limitation shown below.

Rafter cuts are limited to:

1. 115 mm MINIMUM end height
 2. MINIMUM Roof Slopes of 1 in 2 (approximately 26.5°)
- and
3. Must be blocked at the end to prevent rotation of the joist.

Joists without reinforcement are limited to design shear and end reactions up to 6.5 kN. Ply reinforcement can be added to joists with rafter cuts to increase the shear and end reaction capacity of the joist. The detail below shows the proper installation of the reinforcement. With the reinforcement added, the end reaction and shear capacity increase to 12.7 kN. Duration of load increases are permitted as per AS1720.1.

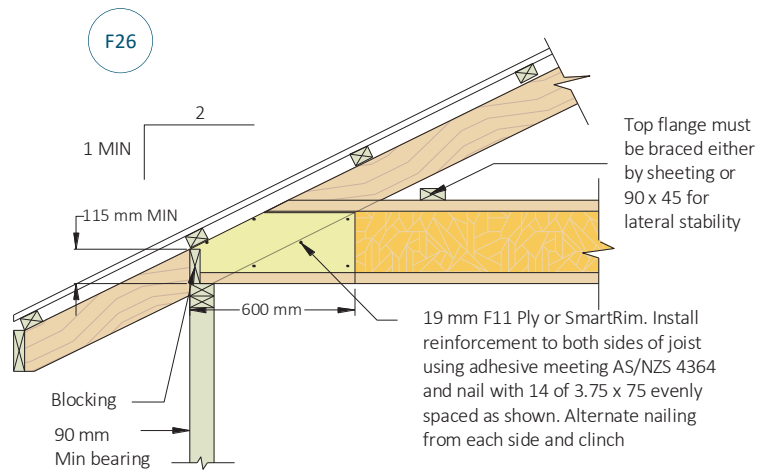

Design for Fire

NOTE:

The examples detailed below contain generic fire detailing principles related to a non-rated floor abutting a rated wall where separation walls require a FRL not less than 60/60/60, commonly found in class 1a applications.

They have been included only to demonstrate that the type of joists within the non-rated floor do not effect the FRL of the rated wall junction, provided the wall is correctly detailed.

It is mandatory that those designing fire separation walls seek out

and specify the latest relevant details either from a Fire Engineer, WoodSolutions® Technical Design Guides and Regulatory Authorities.

If using a tested and certified proprietary system, that system must be followed without variation.

Further information about using SmartFrame product in fire rated applications can be obtained by contacting the Techsupport Helpline on 1300 668 690

Floor joists parallel to the wall

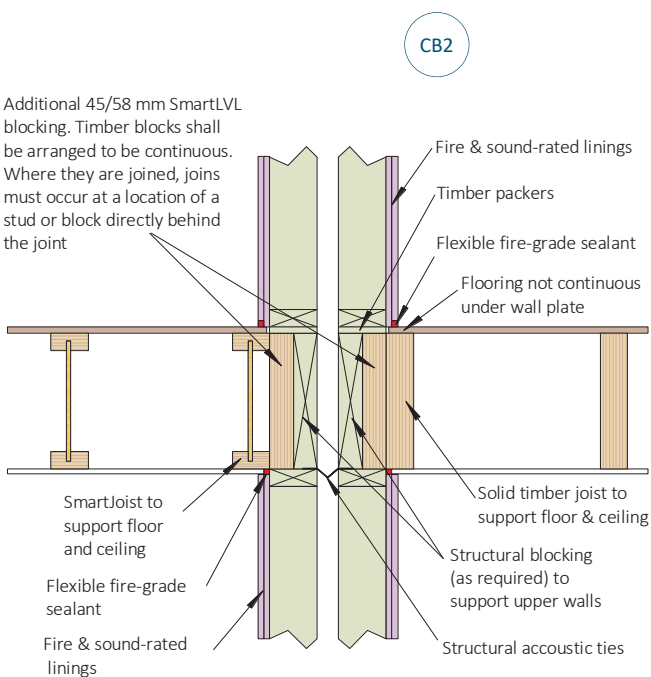

Floor joists perpendicular to the wall

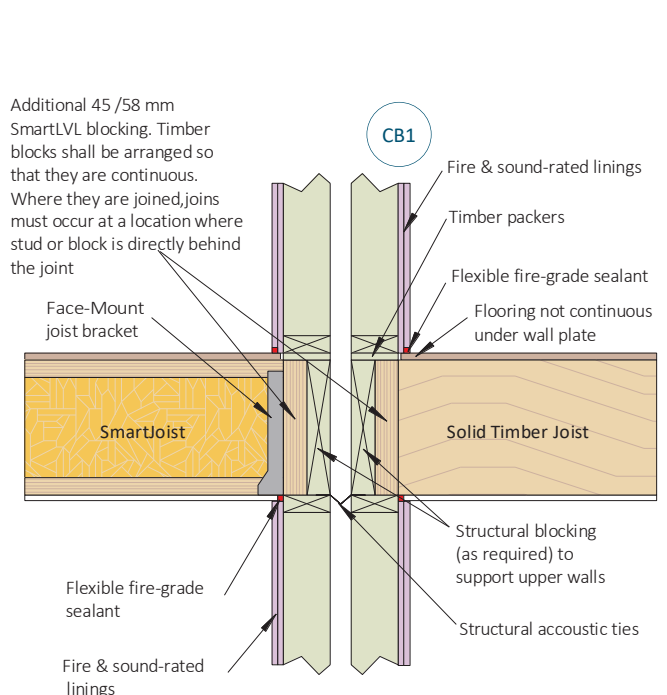

SmartJoist floor set - downs

Floor set- downs

The different depths and flange width of joists within the SmartJoist range make the creation of set-down areas a simple exercise in adding shallower joists in the set down area either being supported on internal/external walls or off trimmers between the deeper joist.

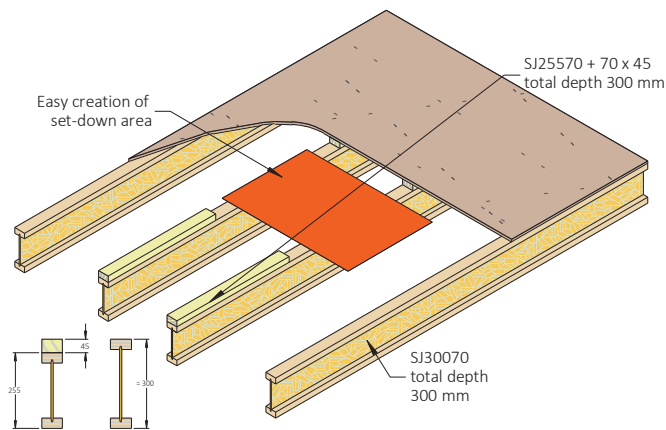

SmartJoist SJ25570

SmartFrame innovation has further simplified the set-down of areas within the most common floor depth 300 mm floor depth by introducing a 255 mm deep set-down joist, the SJ25570. The SJ25570 joist offers a 45 mm set-down from the 300 mm deep joists, BUT, may also be packed up to 300 mm with stock standard 45 mm framing timber.

Example "wet room" shower detail

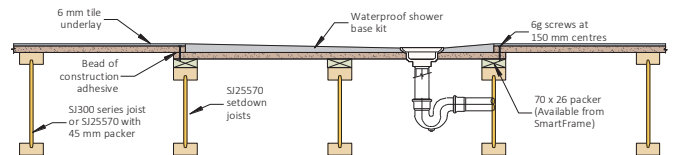

Notes:

1. In the above detail, wet are waterproofing in accordance with NCC volume 2 Part 3.8.1 has omitted for clarity. It is the users responsibility to ensure that any areas subject to moisture are correctly detailed as per NCC and /or local authority requirements
2. This is an example using a proprietary waterproof shower based kit with an exterior rim height of 25 mm. Given the prevalence of this size, lengths of 70 x 26 mm packers are available in conjunction with SJ25570 joist orders only, and are not a separate stock item.

Building envelope watertightness - decks

Deck ledger attachments

As with window and door installations in walls, paying careful attention to flashing details for decks attached to the house exterior is critical to avoid potential rot and mould of inner non treated wall frames and floor systems. Water from direct rainfall, splash from decks and runoff from incorrectly sloped deck surfaces can leak into the exterior wall where the deck attaches to the house.

Several conditions contribute to the water problem:

- The ledger board is simply attached to the house with numerous lag screws or other hardware that penetrate the wall's cladding and drainage plane, but no flashing has been installed to protect these areas
- Water is often trapped behind the ledger board
- Upward splashing of rain from the deck adds significant wetting to the cladding, and inadequate flashing results in wetting and rot in the wall's framing and other internal elements.
- Integrating the attachment of the ledger board with the drainage plane behind the wall's cladding and adding proper flashing will maintain the integrity of the drainage plane and channel water away from the wall's surface.

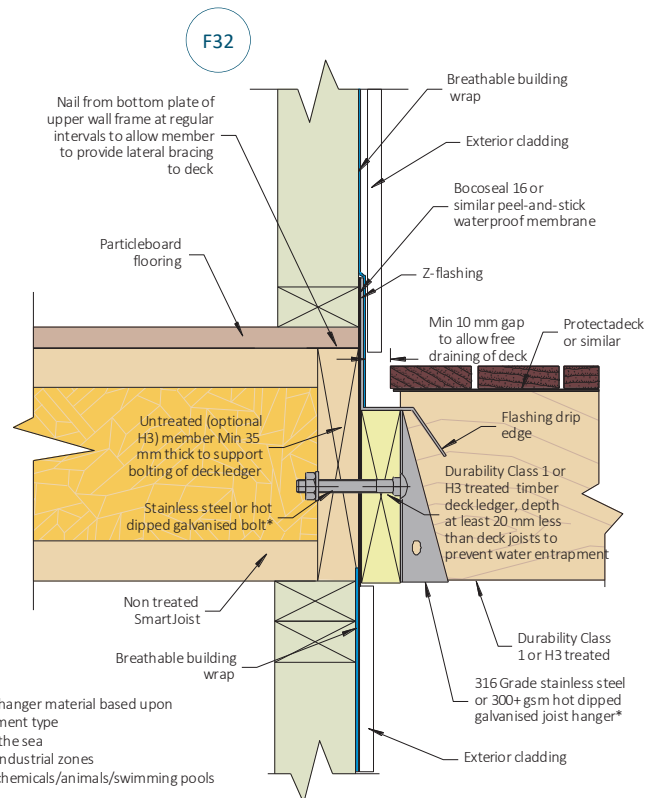

- * Bolt and joist hanger material based upon
1. Timber treatment type
 2. Proximity to the sea
 3. Proximity to Industrial zones
 4. Proximity to chemicals/animals/swimming pools

Example flashing of deck ledger connection to un-treated house frame

Brick ledge cantilevers construction details

Cantilevered SmartJoists as “brick ledge cantilevers” (Max of 160 mm cantilever) to suit upper storey clad frames DO NOT usually require any special modification (other than the necessary timber or ply/LVL closure member attached to the outer edge as shown in details C1 or C2).

The exceptions to this are where concentrated floor loads (e.g.

truncated girders, jamb studs) are supported on an Individual cantilevered joist such that the concentrated roof load area supported exceeds that as shown below for an un-reinforced SmartJoist.

Individual joists may be reinforced, if required, as per details F23 or F24 to support a roof load area (measured in square metres) as shown below.

Joist spacing (mm)	Un-reinforced SmartJoist						Web Filler (F23)						Reinforcing one side (F24)					
	Sheet Roof			Tiled Roof			Sheet Roof			Tiled Roof			Sheet Roof			Tiled Roof		
	300	450	600	300	450	600	300	450	600	300	450	600	300	450	600	300	450	600
SmartJoist	Roof area supported (m²)																	
SJ20044	7.8	6.9	6.0	4.6	4.0	3.5	9.3	8.3	7.5	5.4	4.9	4.4	11.2	10.3	9.4	6.4	5.7	5.2
SJ24040	7.6	6.5	5.5	4.5	3.8	3.2	9.1	8.0	7.0	5.3	4.7	4.1	11.0	9.9	8.9	6.2	5.5	4.9
SJ24051	9.1	8.0	6.9	5.3	4.7	4.0	10.6	9.4	8.3	6.2	5.5	4.9	12.6	11.4	10.3	7.1	6.4	5.7
SJ24070	11.4	10.2	9.1	6.7	6.0	5.3	12.9	11.7	10.5	7.5	6.9	6.2	14.9	13.7	12.5	8.5	7.7	7.0
SJ24090	15.0	13.7	12.5	8.8	8.2	7.3	16.4	15.2	14.0	9.6	8.9	8.2	18.4	17.1	15.9	10.5	9.7	9.0
SJ25570	11.3	10.0	8.9	6.6	6.1	5.2	12.7	11.5	10.4	7.5	6.7	6.1	14.7	13.5	12.3	8.4	7.6	6.8
SJ30040	7.2	6.0	4.9	4.2	3.5	2.9	8.7	7.5	6.3	5.1	4.5	3.7	10.7	9.4	8.3	6.0	5.3	4.5
SJ30051	8.7	7.4	6.2	5.1	4.4	3.7	10.2	8.9	7.7	6.0	5.2	4.5	12.2	10.9	9.7	6.9	6.1	5.3
SJ30070	11.0	9.6	8.4	6.4	5.8	4.9	12.5	11.1	9.9	7.3	6.5	5.8	14.4	13.1	12.3	8.2	7.4	6.5
SP30095	14.6	13.1	11.7	8.5	7.9	6.9	16.0	14.5	13.2	9.4	8.5	7.7	18.0	16.5	15.2	10.2	9.3	8.4
SJ36058	11.4	9.9	8.6	6.7	5.8	5.0	12.8	11.4	10.1	7.5	6.7	5.9	14.8	13.4	12.0	8.4	7.5	6.5
SJ36090	14.1	12.5	11.1	8.3	7.4	6.5	15.6	14.0	12.6	9.1	8.2	7.4	17.6	16.0	14.6	9.9	9.0	8.0
SJ40058	11.2	10.1	8.6	6.6	5.9	5.0	12.7	11.5	10.1	7.4	6.8	5.9	14.7	13.5	12.0	8.6	7.9	7.0
SJ40090	13.9	12.2	10.7	8.1	7.1	6.3	15.3	13.7	12.2	9.0	8.0	7.1	17.3	15.6	14.1	9.8	8.8	7.8

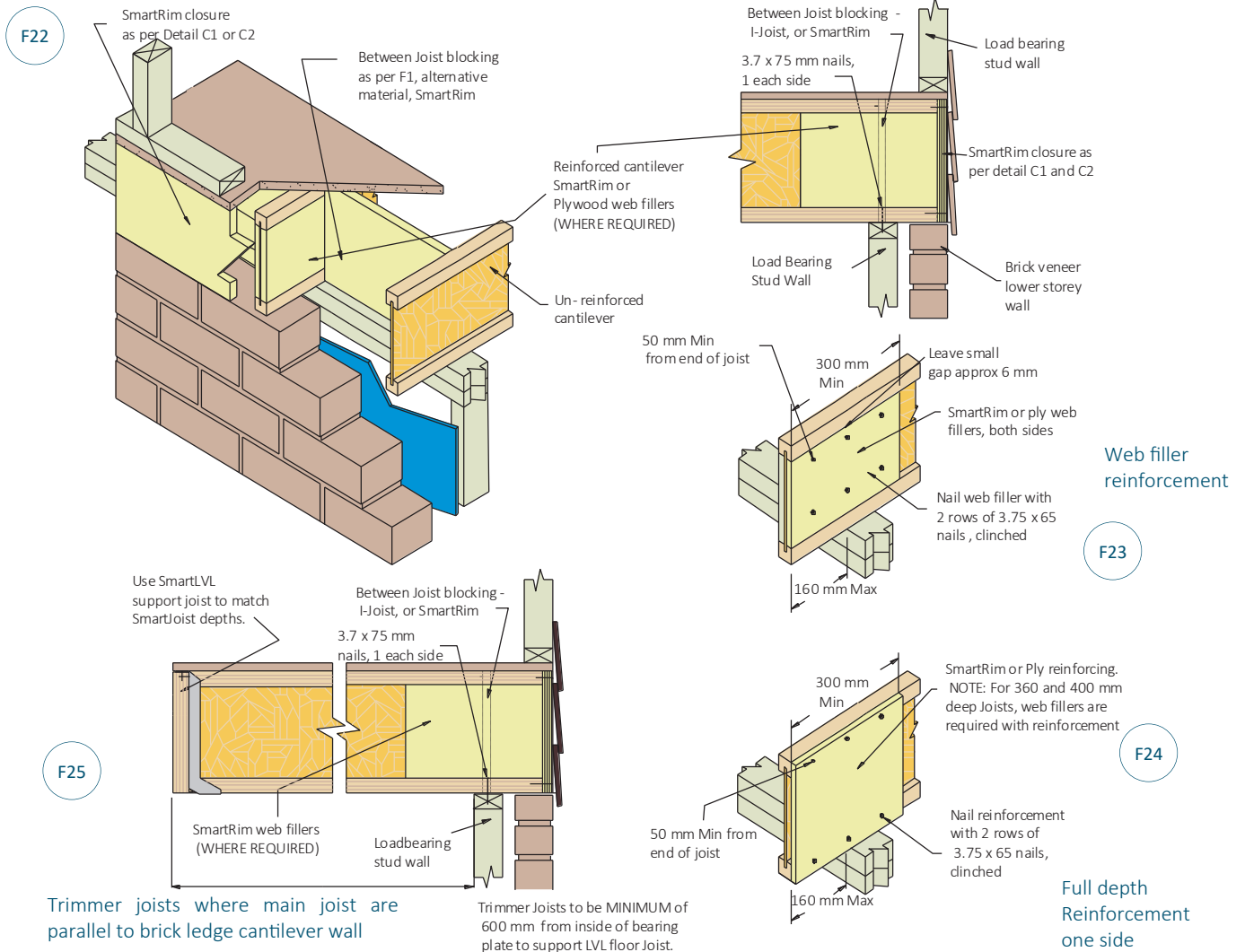

SmartJoist hole and duct charts

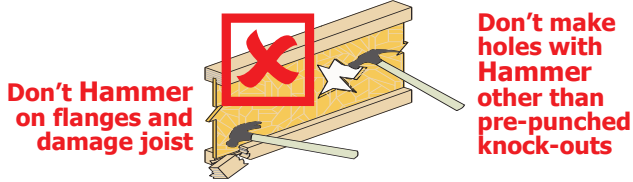

Don't make holes with Hammer other than pre-punched knock-outs

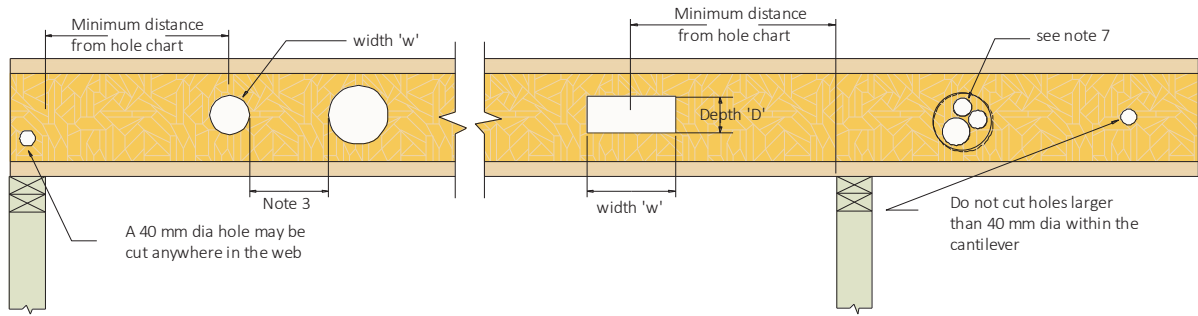
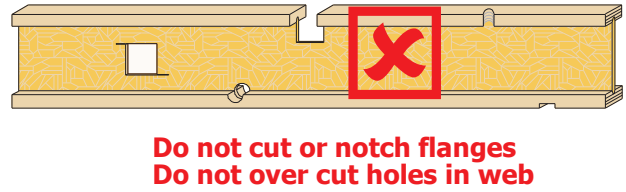

Note: The most accurate method to design the allowable web penetration size and distance from support for SmartJoists is to use the SmartFrame software. The table below will give conservative results in some instances. Also, advice on hole size and location may be obtained by contacting the tech support helpline on 1300 668 690 or at techsupport@tilling.com.au.

Assumed loading (DL G = 62 kg/m², FLL Q = 2.0 kPa, FPL Q = 1.8 kN)

Joist code	Joist span* (mm)	Joist spacing (mm)	Circular/square holes								Rectangular holes				
			Hole diameter/square hole width (mm)								Depth x width (mm)				
			75	100	125	150	175	200	225	250	125x150	150x300	175x350	200x400	
Minimum distance from any support to the centre of the hole (mm)															
SJ20044	600-999	300 to 600	300	300	ns	ns	ns	ns	ns	ns	ns	ns	ns	ns	ns
	1000-1499		300	300	ns	ns	ns	ns	ns	ns	ns	ns	ns	ns	ns
	1500-1999		300	300	ns	ns	ns	ns	ns	ns	ns	ns	ns	ns	ns
	2000-2499		300	600	ns	ns	ns	ns	ns	ns	ns	ns	ns	ns	ns
	2500-2999		300	800	ns	ns	ns	ns	ns	ns	ns	ns	ns	ns	ns
	3000-3300		300	900	ns	ns	ns	ns	ns	ns	ns	ns	ns	ns	ns
SJ24040	600-999	300 to 600	300	300	300	ns	ns	ns	ns	ns	ns	ns	ns	ns	ns
	1000-1499		300	300	300	ns	ns	ns	ns	ns	ns	ns	ns	ns	ns
	1500-1999		300	300	300	Span/2	ns	ns	ns	ns	ns	750	Span/2	ns	ns
	2000-2499		300	300	300	Span/2	ns	ns	ns	ns	ns	1000	Span/2	ns	ns
	2500-2999		300	300	500	Span/2	ns	ns	ns	ns	ns	Span/2	Span/2	ns	ns
	3000-3500		300	300	800	Span/2	ns	ns	ns	ns	ns	Span/2	Span/2	ns	ns
SJ24051	600-999	300 to 600	300	300	300	ns	ns	ns	ns	ns	ns	ns	ns	ns	ns
	1000-1499		300	300	300	ns	ns	ns	ns	ns	ns	ns	ns	ns	ns
	1500-1999		300	300	300	Span/2	ns	ns	ns	ns	ns	750	Span/2	ns	ns
	2000-2499		300	300	300	Span/2	ns	ns	ns	ns	ns	1000	Span/2	ns	ns
	2500-2999		300	300	500	Span/2	ns	ns	ns	ns	ns	Span/2	Span/2	ns	ns
	3000-3499		300	300	800	Span/2	ns	ns	ns	ns	ns	Span/2	Span/2	ns	ns
	3500-3800		300	300	1000	Span/2	ns	ns	ns	ns	ns	Span/2	Span/2	ns	ns
SJ24070	600-999	300 to 600	300	300	300	ns	ns	ns	ns	ns	ns	ns	ns	ns	ns
	1000-1499		300	300	300	ns	ns	ns	ns	ns	ns	300	ns	ns	ns
	1500-1999		300	300	300	Span/2	ns	ns	ns	ns	ns	600	Span/2	ns	ns
	2000-2499		300	300	300	Span/2	ns	ns	ns	ns	ns	900	Span/2	ns	ns
	2500-2999		300	300	500	Span/2	ns	ns	ns	ns	ns	1250	Span/2	ns	ns
	3000-3499		300	300	800	Span/2	ns	ns	ns	ns	ns	1500	Span/2	ns	ns
	3500-3999		300	300	1000	Span/2	ns	ns	ns	ns	ns	Span/2	Span/2	ns	ns
	4000-4100		300	450	1100	Span/2	ns	ns	ns	ns	ns	Span/2	Span/2	ns	ns

SmartJoist hole charts (Cont'd)

Assumed load (DL G = 62 kg/m ² , FLL Q = 2.0 kPa, FPL Q = 1.8 kN)														
Joist code	Joist span* (mm)	Joist spacing (mm)	Circular/square holes								Rectangular holes			
			Hole diameter/square hole width (mm)								Depth x width (mm)			
			75	100	125	150	175	200	225	250	125x150	150x300	175x350	200x400
			Minimum distance from any support to the centre of the hole (mm)											
SJ24090	600-999	300 to 600	300	300	300	ns	ns	ns	ns	ns	ns	ns	ns	ns
	1000-1499		300	300	300	ns	ns	ns	ns	ns	300	ns	ns	ns
	1500-1999		300	300	300	700	ns	ns	ns	ns	500	750	ns	ns
	2000-2499		300	300	300	1000	ns	ns	ns	ns	800	1000	ns	ns
	2500-2999		300	300	400	1150	ns	ns	ns	ns	1100	Span/2	ns	ns
	3000-3499		300	300	700	1400	ns	ns	ns	ns	1400	Span/2	ns	ns
	3500-3999		300	300	800	1550	ns	ns	ns	ns	1700	Span/2	ns	ns
	4000-4100		300	300	900	1600	ns	ns	ns	ns	1800	Span/2	ns	ns
SJ25570	600-999	300 to 600	300	300	300	300	ns	ns	ns	ns	300	300	ns	ns
	1000-1499		300	300	300	300	ns	ns	ns	ns	300	500	ns	ns
	1500-1999		300	300	300	span/2	ns	ns	ns	ns	400	800	ns	ns
	2000-2499		300	300	600	span/2	ns	ns	ns	ns	700	1000	ns	ns
	2500-2999		300	300	900	span/2	ns	ns	ns	ns	1000	1300	ns	ns
	3000-3499		300	700	1300	span/2	ns	ns	ns	ns	1300	1600	ns	ns
	3500-3999		300	1100	1600	span/2	ns	ns	ns	ns	1700	1900	ns	ns
	4000-4300		300	1400	1800	span/2	ns	ns	ns	ns	1900	span/2	ns	ns
SJ30040	600-999	300 to 600	300	300	300	300	300	300	ns	ns	300	300	ns	ns
	1000-1499		300	300	300	300	300	300	ns	ns	300	500	Span/2	ns
	1500-1999		300	300	300	300	300	500	ns	ns	300	Span/2	Span/2	Span/2
	2000-2499		300	300	300	300	300	700	ns	ns	500	Span/2	Span/2	Span/2
	2500-2999		300	300	300	300	400	1000	ns	ns	900	Span/2	Span/2	Span/2
	3000-3499		300	300	300	300	600	1200	ns	ns	1300	Span/2	Span/2	Span/2
	3500-3999		300	300	300	300	900	1450	ns	ns	1750	Span/2	Span/2	Span/2
	4000-4100		300	300	300	400	1000	1500	ns	ns	Span/2	Span/2	Span/2	ns
SJ30051	600-999	300 to 600	300	300	300	300	300	300	ns	ns	300	300	ns	ns
	1000-1499		300	300	300	300	300	300	ns	ns	300	500	Span/2	ns
	1500-1999		300	300	300	300	300	500	ns	ns	300	750	Span/2	Span/2
	2000-2499		300	300	300	300	300	700	ns	ns	400	Span/2	Span/2	Span/2
	2500-2999		300	300	300	300	400	1000	ns	ns	800	Span/2	Span/2	Span/2
	3000-3499		300	300	300	300	600	1200	ns	ns	1200	Span/2	Span/2	Span/2
	3500-3999		300	300	300	300	900	1450	ns	ns	1600	Span/2	Span/2	Span/2
	4000-4300		300	300	300	400	1000	1600	ns	ns	1800	Span/2	Span/2	ns
SJ30070	600-999	300 to 600	300	300	300	300	300	300	ns	ns	300	300	ns	ns
	1000-1499		300	300	300	300	300	300	ns	ns	300	500	Span/2	ns
	1500-1999		300	300	300	300	300	500	ns	ns	300	750	Span/2	Span/2
	2000-2499		300	300	300	300	300	700	ns	ns	400	1000	Span/2	Span/2
	2500-2999		300	300	300	300	400	950	ns	ns	700	1250	Span/2	Span/2
	3000-3499		300	300	300	300	600	1200	ns	ns	1000	Span/2	Span/2	Span/2
	3500-3999		300	300	300	300	900	1450	ns	ns	1400	Span/2	Span/2	Span/2
	4000-4499		300	300	300	500	1100	1700	ns	ns	1800	Span/2	Span/2	Span/2
4500-4600	300	300	300	700	1200	1800	ns	ns	1900	Span/2	Span/2	Span/2		
SJ30090	600-999	300 to 600	300	300	300	300	300	300	ns	ns	300	300	ns	ns
	1000-1499		300	300	300	300	300	300	ns	ns	300	400	Span/2	ns
	1500-1999		300	300	300	300	300	300	ns	ns	300	750	Span/2	Span/2
	2000-2499		300	300	300	300	300	600	ns	ns	300	950	Span/2	Span/2
	2500-2999		300	300	300	300	300	800	ns	ns	500	1200	Span/2	Span/2
	3000-3499		300	300	300	300	400	1100	ns	ns	800	1500	Span/2	Span/2
	3500-3999		300	300	300	300	700	1300	ns	ns	1200	1750	Span/2	Span/2
	4000-4499		300	300	300	300	950	1600	ns	ns	1600	Span/2	Span/2	Span/2
4500-4900	300	300	300	500	1100	1800	ns	ns	1800	Span/2	Span/2	Span/2		

SmartJoist hole charts (Cont'd)

Assumed load (DL G = 62 kg/m ² , FLL Q = 2.0 kPa, FPL Q = 1.8 kN)															
Joist code	Joist span (mm)	Joist* spacing (mm)	Circular/square holes								Rectangular holes				
			Hole diameter/square hole width (mm)								Depth x width (mm)				
			75	100	125	150	175	200	225	250	125x150	150x300	175x350	200x400	
			Minimum distance from any support to the centre of the hole (mm)												
SJ36058	1000-1499	300 to 600	300	300	300	300	300	300	300	300	300	300	300	400	ns
	1500-1999		300	300	300	300	300	300	300	300	400	300	300	700	span/2
	2000-2499		300	300	300	300	300	300	300	300	700	300	550	900	span/2
	2500-2999		300	300	300	300	300	300	300	400	900	300	850	1200	span/2
	3000-3499		300	300	300	300	300	300	300	650	1200	300	1200	1500	span/2
	3500-3999		300	300	300	300	300	300	400	900	1400	300	1500	1750	span/2
	4000-4499		300	300	300	300	300	300	600	1100	1700	300	1800	span/2	span/2
	4500-5000		300	300	300	300	300	300	800	1400	1900	300	2200	span/2	span/2
SJ36090	1000-1499	300 to 600	300	300	300	300	300	300	300	300	300	300	300	300	300
	1500-1999		300	300	300	300	300	300	300	300	300	300	300	450	700
	2000-2499		300	300	300	300	300	300	300	300	400	300	300	750	1000
	2500-2999		300	300	300	300	300	300	300	300	650	300	450	1000	1250
	3000-3499		300	300	300	300	300	300	300	300	900	300	800	1300	1500
	3500-3999		300	300	300	300	300	300	300	500	1150	300	1100	1600	span/2
	4000-4499		300	300	300	300	300	300	300	750	1400	300	1450	1900	span/2
	4500-4999		300	300	300	300	300	300	400	1000	1650	300	1800	2200	span/2
5000-5400	300	300	300	300	300	300	600	1200	1800	300	2100	2500	span/2		
SJ40058	1000-1499	300 to 600	300	300	300	300	300	300	300	300	300	300	300	300	300
	1500-1999		300	300	300	300	300	300	300	300	300	300	300	300	400
	2000-2499		300	300	300	300	300	300	300	300	300	300	300	300	700
	2500-2999		300	300	300	300	300	300	300	300	300	300	300	400	1000
	3000-3499		300	300	300	300	300	300	300	300	300	300	300	800	1300
	3500-3999		300	300	300	300	300	300	300	300	300	300	300	1100	1600
	4000-4499		300	300	300	300	300	300	300	300	300	300	500	1500	1900
	4500-4999		300	300	300	300	300	300	300	300	500	300	1000	1900	2300
	5000-5499		300	300	300	300	300	300	300	300	700	300	1600	2300	2600
	5500-6000		300	300	300	300	300	300	300	400	1000	300	1900	Span/2	Span/2
SJ40090	1000-1499	300 to 600	300	300	300	300	300	300	300	300	300	300	300	300	300
	1500-1999		300	300	300	300	300	300	300	300	300	300	300	300	300
	2000-2499		300	300	300	300	300	300	300	300	300	300	300	300	500
	2500-2999		300	300	300	300	300	300	300	300	300	300	300	300	800
	3000-3499		300	300	300	300	300	300	300	300	300	300	300	400	1100
	3500-3999		300	300	300	300	300	300	300	300	300	300	300	800	1400
	4000-4499		300	300	300	300	300	300	300	300	300	300	300	1100	1700
	4500-4999		300	300	300	300	300	300	300	500	300	300	300	1600	2100
	5000-5499		300	300	300	300	300	300	300	300	900	300	600	2000	2400
	5500-6000		300	300	300	300	300	300	300	400	1000	300	1300	2400	2800

Notes:

1. The hole chart is generated for single span joists with a maximum floor dead load of 62 kg/m² with no wall or roof loads. It therefore does not apply for joists supporting either parallel or perpendicular load bearing walls. These scenarios can be analysed by using the appropriate model within the SmartFrame software. Help can be obtained for continuous spans by contacting the tech support helpline on 1300 668 690 or at techsupport@tilling.com.au
2. Hole locations are suitable for joist spacings up to 600 mm centres. Holes may be permitted closer to supports for some member when spacings of 450 or 300 mm are used
3. The clear distance between holes must equal or exceed twice the diameter of the largest hole, or twice the longest side of a rectangular hole and no more than 3 holes in excess of 75 mm are allowed in any span
4. Do not cut or damage flanges under any circumstances
5. Except as noted in 1 and 2 above, a 40 mm hole at a minimum of 450 mm centres is allowed to be drilled anywhere in the web EXCEPT in cantilevered spans
6. If possible, holes in web should be positioned mid height, minimum edge clearance from any flange is 6 mm
7. A group of round holes at approximately the same location shall be permitted if they meet the requirements for a single round hole circumscribed around them.

Openings within SmartFrame floors

Opening trimmer

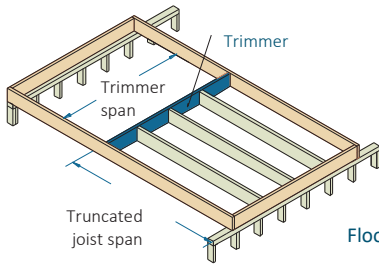

The tables below are for trimmer members of SmartJoists and LVL. Other SmartFrame engineered timber products may also be used for this member, the designs for each of these other material types can be simply calculated by using the SmartFrame software or by contacting the tech support helpline on 1300 668 690 or at techsupport@tilling.com.au.

SmartJoist	Maximum trimmer span (mm)				
	Truncated joist span (mm)				
	1.5	3.0	4.5	6.0	7.2
SJ20044	3700	3000	2600	2300	2100
SJ24040	4000	3300	2900	2600	2400
SJ24051	4300	3500	3100	2800	2500
SJ24070	4600	3800	3400	3000	2800
SJ24090	4800	4000	3500	3300	3000
SJ30040	4600	3800	3400	3100	2800
SJ25570	4700	3900	3500	3100	2500
SJ30051	4900	3900	3600	3300	3100
SJ30070	5200	4300	3800	3500	3300
SJ30090	5500	4500	4000	3700	3500
SJ36058	5600	4700	4200	3800	3600
SJ36090	6100	5000	4500	4100	3900
SJ40058	5900	4900	4400	3700	3100
SJ40090	6500	5400	4800	4400	4100

Floor live load 1.5 kPa

SmartLVL 15	Maximum trimmer span (mm)				
	Truncated joist span (mm)				
	1.5	3.0	4.5	6.0	7.2
200x42	3900	3200	2800	2500	2300
240x42	4500	3800	3300	3000	2800
300x42	5300	4500	4000	3700	3500
360x42	6100	5100	4600	4300	4100
200x58	4300	3600	3100	2800	2600
240x58	4900	4100	3700	3400	3100
300x58	5800	4900	4400	4100	3900
360x58	6600	5600	5000	4700	4400
400x58	7100	6000	5400	5000	4800

Trimmer Joists

Trimming joists at floor opening often support the loads from stair stringers, as well as the concentrated load from the trimmer. The table below has been set up to allow a load from stairs equally supported from the floor below (or above) and the trimmer joists. In many cases this will provide a conservative result. Alternative designs can be readily obtained by using the SmartFrame software or by contacting the tech support helpline on 1300 668 690 or at techsupport@tilling.com.au.

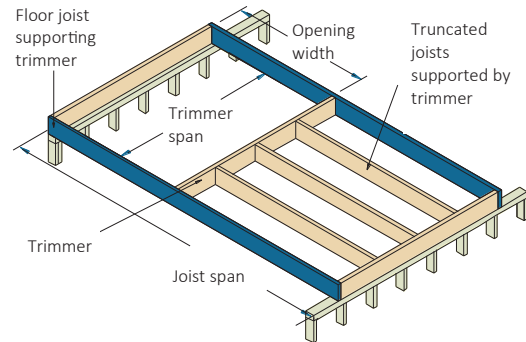

Note: Table based on spacing of 600 mm and maximum of 10 mm DL deflection, FLL of 2.0 kPa and FPL of 2.7 kN

SmartJoists

SmartFrame EWP	Maximum trimming joist span (mm)											
	Opening width 900 (mm)				Opening width 1800 (mm)				Opening width 2700 (mm)			
	Trimmer span (mm)				Trimmer span (mm)				Trimmer span (mm)			
	2000	3000	4000	5000	2000	3000	4000	5000	2000	3000	4000	5000
SJ20044	3300	3100	2800	2600	3400	3200	3100	3000	3700	3600	3600	3500
SJ24040	3700	3400	3200	3000	3600	3400	3100	3000	4000	3800	3700	3700
SJ24051	3900	3600	3400	3200	3800	3600	3400	3300	4100	4000	3900	3800
SJ24070	4200	3900	3700	3500	4100	3800	3600	3500	4400	4200	4000	4000
SJ24090	4500	4100	3900	3700	4300	4000	3800	3600	4500	4300	4200	4000
SJ25570	4800	4500	4200	4000	4600	4300	4100	3900	4800	4600	4400	4300
SJ30040	4300	4000	3700	3500	4100	3900	3700	3500	4400	4200	4100	3900
SJ30051	4500	4200	3900	3700	4300	4000	3800	3700	4600	4400	4200	4100
SJ30070	4900	4500	4200	4000	4600	4300	4100	3900	4800	4600	4400	4300
SJ30090	5100	4800	4500	4200	4900	4500	4300	4100	5100	4700	4500	4400
SJ36058	5300	4900	4700	4400	5000	4600	4400	4200	5200	4800	4600	4400
SJ36090	5700	5300	5000	4800	5400	5000	4800	4400	5500	5100	4900	4700
SJ40058	5800	5400	5100	4700	5500	5100	4800	4500	5500	5200	5000	4800
SJ40090	6100	5800	5500	5200	5800	5300	5000	4800	5800	5400	5100	4900

SmartLVL 15

200x42	3600	3200	2900	2700	3600	3300	3100	3000	4000	3900	3700	3600
240x42	4200	3800	3500	3300	4100	3800	3600	3400	4400	4200	4000	3900
300x42	5100	4600	4300	4100	4800	4400	4100	4000	5000	4700	4500	4300
360x42	6000	5400	5100	4800	5500	5000	4700	4500	5600	5200	5000	4800
200x58	3900	3600	3300	3000	3900	3600	3400	3200	4200	4000	3900	3900
240x58	4600	4200	3900	3700	4400	4100	3800	3700	4700	4400	4200	4100
300x58	5600	5100	4800	4500	5200	4800	4500	4300	5300	5000	4800	4600
360x58	6600	6000	5600	5300	6000	5500	5100	4900	6000	5600	5300	5100
400x58	7200	6600	6200	5700	6500	6000	5600	5300	6500	6000	5700	5400

SmartJoist cantilevers supporting load bearing walls (Cont'd)

Spans in the preceding table are based upon a uniform roof load width at the cantilever end of each joist. The presence of large windows or openings within the load bearing wall supported by these cantilevered joists create concentrated loads at the edges of such openings. The joists supporting the concentrated loads will require special engineering considera-

tion to avoid excess loads and differential deflections between adjacent joists. It is strongly recommended that where concentrated loads occur on cantilevered joists that advice be sought from the tech support helpline on 1300 668 690 or at techsupport@tilling.com.au.

Example construction details for load-bearing cantilevers

Note: Option 1 with cantilever reinforced with an extra SmartJoist is equivalent to option 2 with 2 sheets of ply reinforcement.

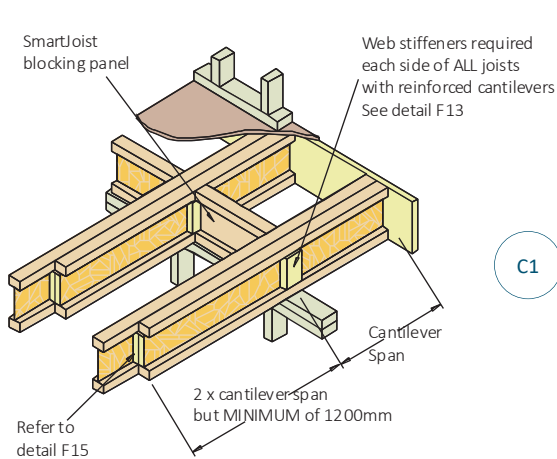

C1

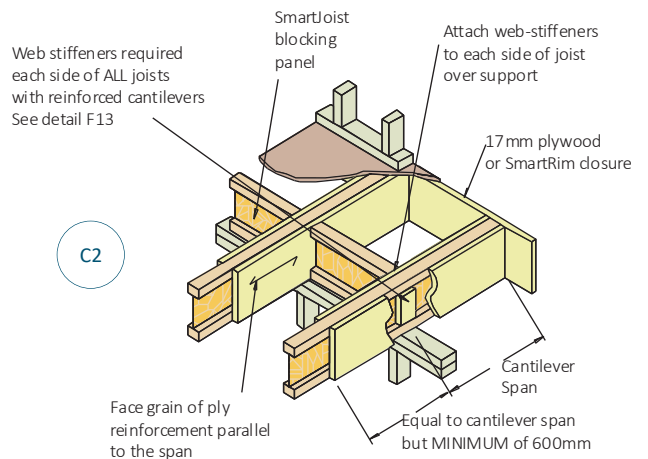

C2

NOTE:
Block together full length with filler blocks as per detail F15 of the SmartJoist Design Guide

NOTE:
15 mm F11 structural ply is required on one or both sides of the joist (See Tables). Depth shall match the full height of the Smartjoist. Nail with 3.15 x 65 nails at 100mm ctrs in a staggered pattern.

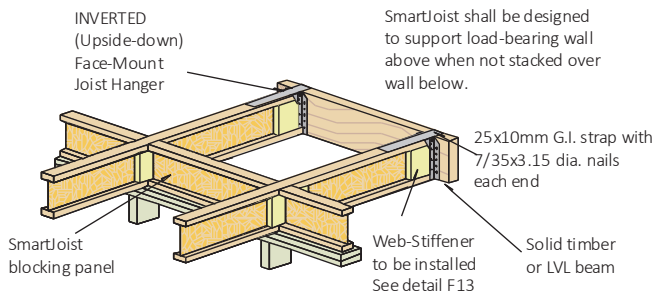

C3

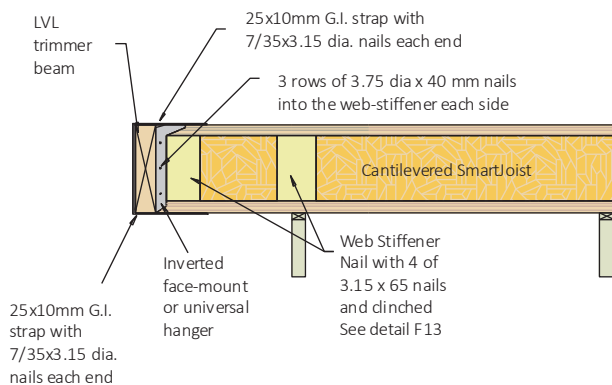

C4

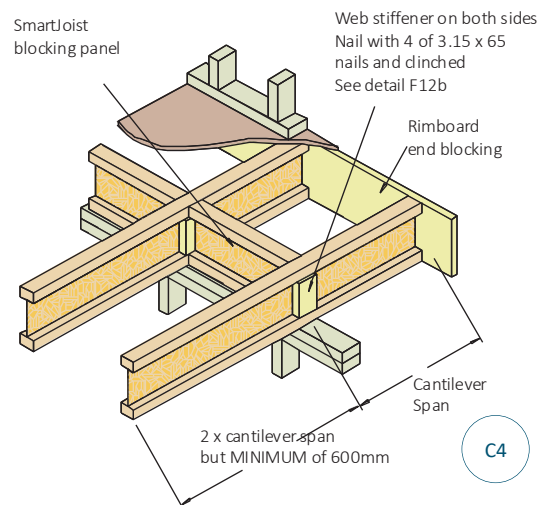

SmartJoists supporting parallel load-bearing walls

Fitted floors

Double SmartJoists required for fixing of floor and ceiling, and when required by table below
AND
for SmartJoists with 40 mm wide flanges

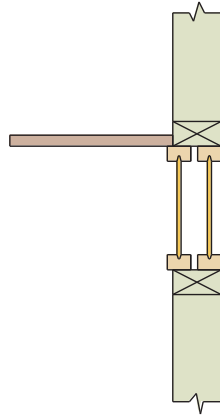

Platform floors

Single SmartJoist with flange > 50 mm may be used, but requires alternative fixing for ceiling.
NOT suitable for SmartJoists with 40 mm wide flanges e.g SJ24040

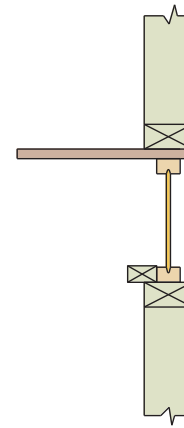

Joists continuously supported by lower walls

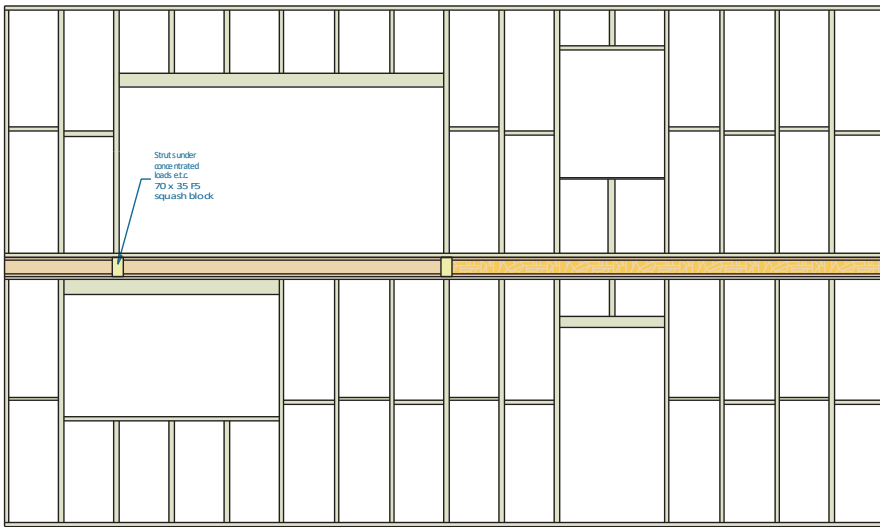

Fix 90x45mm F5 compression block to SmartJoist where load exceeds 6.5 kN*

Concentrated point loads (eg, girder trusses, TG's all beams & jamb studs)

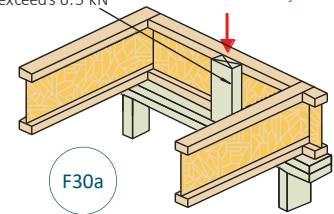

F30a

Single SmartJoists with flange width < plate width

Concentrated point loads (eg, girder trusses, TG's all beams & jamb studs)

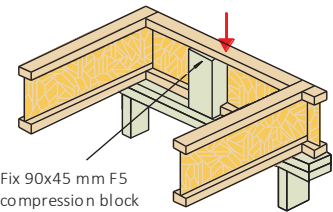

Fix 90x45 mm F5 compression block to SmartJoist where load exceeds 6.5 kN*

F30b

Single SmartJoists with flange width >= plate width

Concentrated point loads (eg, girder trusses, TG's all beams & jamb studs)

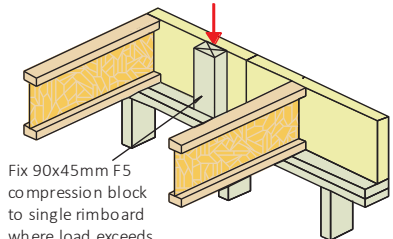

Fix 90x45mm F5 compression block to single rimboard where load exceeds 26.0 kN*

F30c

Single SmartRim

Joist non-continuously supported by lower wall

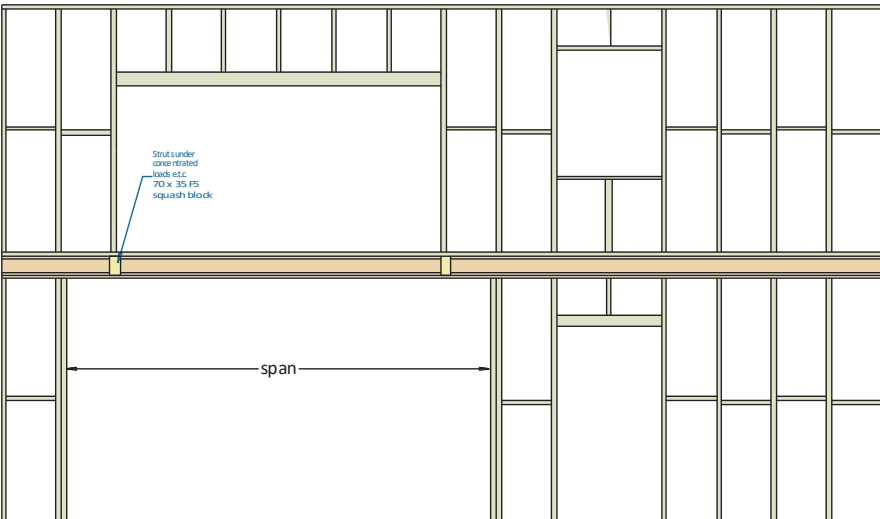

Single (and double) SmartJoists are adequate to transfer uniformly distributed compression loads up to 29 kN/m per joist from loadbearing walls to a continuous rigid support below. Detail F5 and F8 are used to transfer concentrated loads where walls are perpendicular to the joists. Details F30a, F30b and F30c above must be used to transfer concentrated loads through parallel SmartJoists where the instantaneous reaction exceeds 6.5 kN and

exceeds 26.0 kN for single SmartRim (reaction needs to be factored for load duration).

The table below gives allowable spans for single and double joists NOT continuously supported by a parallel wall. Care must always be taken to adequately support the web of the joists from concentrated point loads from above by adopting details F13.

Single SmartJoists supporting parallel load bearing walls

Floor load width (mm)		600			600		
Roof load width (mm)		1500	3000	5000	1500	3000	5000
SmartJoist code	Roof mass (kg/m ²)	Maximum recommended SmartJoist span (mm)					
		Single Span			Continuous Span		
SJ20044	40	2450	2250	2050	3450	2900	2400
	90	2200	1900	1400	2800	2100	1600
SJ24040	40	2800	2550	2300	3550	3150	2800
	90	2500	2150	1750	3100	2550	2000
SJ24051	40	3000	2750	2500	4050	3600	2950
	90	2700	2300	1750	3450	2550	2000
SJ24070	40	3300	3000	2700	4300	3600	2950
	90	2950	2450	1750	3450	2550	2000
SJ24090	40	3550	3200	2900	4550	4250	3500
	90	3150	2700	2150	4100	3050	2300
SJ25570	40	3450	3150	2850	4450	4200	3750
	90	3100	2650	2300	4100	3250	2450
SJ30040	40	3350	3100	2800	4050	3600	3150
	90	3000	2600	2250	3500	2900	2450
SJ30051	40	3600	3300	3000	4600	4100	3600
	90	3250	2800	2250	4000	3300	2550
SJ30070	40	3850	3600	3250	4900	4600	3800
	90	3550	3050	2250	4450	3300	2550
SJ30090	40	4050	3800	3500	5200	4850	4450
	90	3750	3250	2750	4800	3850	2950
SJ36058	40	4150	3900	3650	5300	5000	4400
	90	3850	3400	2800	4850	4000	3100
SJ36090	40	4500	4200	3900	5750	5400	5000
	90	4150	3700	3250	5300	4650	3550
SJ40058	40	4400	4100	3800	3700	3100	2000
	90	4100	3600	2800	3200	2200	1550
SJ40090	40	4750	4450	4150	6100	5700	5350
	90	4400	3950	3550	5650	5100	4000

Double SmartJoists supporting parallel load bearing walls

Floor load width (mm)		600			600		
Roof load width (mm)		1500	3000	5000	1500	3000	5000
SmartJoist code	Roof mass (kg/m ²)	Maximum recommended SmartJoist span (mm)					
		Single Span			Continuous Span		
2/SJ20044	40	3200	2950	2700	4200	3950	3700
	90	2900	2500	2200	3900	3500	2750
2/SJ24040	40	3650	3350	3050	4600	4300	3950
	90	3300	2850	2500	4250	3600	3050
2/SJ24051	40	3850	3600	3300	4850	4550	4250
	90	3550	3100	2700	4500	4100	3400
2/SJ24070	40	4100	3850	3600	5200	4900	4550
	90	3800	3350	2950	4800	4350	3400
2/SJ24090	40	4350	4050	3800	5500	5150	4850
	90	4000	3600	3150	5100	4600	4050
2/SJ25570	40	4250	4000	3750	5400	5050	4750
	90	3950	3550	3100	5000	4500	4100
2/SJ30040	40	4150	3900	3650	5250	4950	4500
	90	3850	3450	3000	4850	4100	3450
2/SJ30051	40	4350	4100	3850	5550	5200	4850
	90	4050	3650	3250	5150	4650	3950
2/SJ30070	40	4650	4400	4100	5950	5550	5200
	90	4300	3900	3500	5500	4950	4350
2/SJ30090	40	4950	4650	4350	6250	5900	5500
	90	4550	4100	3750	5800	5250	4750
2/SJ36058	40	5050	4750	4450	6400	6050	5650
	90	4700	4250	3850	5950	5400	4800
2/SJ36090	40	5450	5150	4800	6950	6550	6100
	90	5050	4550	4150	6450	5800	5300
2/SJ40058	40	5350	5000	4700	4650	4300	3950
	90	4900	4400	4050	4200	3750	3100
2/SJ40090	40	5800	5450	5100	7400	6950	6500
	90	5350	4850	4400	6850	6200	5600

NOTES:

- Bearing lengths - minimum of 30 mm
- Wall load 0.37 kPa
- Wind speeds N1-N3
- Floor load loads 1.5 kPa or 1.8 kN point live load
- Upper floor dead load 40 kg/m²
- Deflection limits: permanent load - span/300 or 12 mm max LL - span/360 or 9 mm max.

Tie down and bracing wall support details

The tie-down needs of the structure are related to the applied wind loads and the effect of bracing walls either parallel or perpendicular to the supporting member. Reference should be made to AS 1684 for further guidance on this issue.

Floor systems are integral in the transfer of all vertical and horizontal loads to the footing system. Methods to transfer both uplifts and bracing loads to the floor system will vary dependent upon:

1. Loads are applied into a structural element that is running parallel to the bracing/tie-down panel
2. Loads are applied into a structural element that is running perpendicular to the bracing/tie-down panel.

AS 1684 requires bracing to be approximately evenly distributed and provided in both directions as shown below. Care must be taken with tie down to resist bracing loads because the applied

load could be either up or down, whereas the wind uplift forces are always vertically up.

Where the bracing walls are parallel to a floor joist, the joist involved must be designed to resist the applied forces imposed, over and above any gravity and normal live loads associated with the floor system.

The general details relating to the tie-down provisions of solid end section timber may be adopted for SmartJoists, except that under NO circumstances is it permitted to bolt through either the top or bottom flange, except when the joist is fully supported upon a wall plate or similar as shown below. Care must also be taken to ensure that any bolts etc. drilled through solid timber joists do not compromise the structural integrity of that member.

A conservative solution to bracing walls directly above parallel joists is to adopt a double joist at that location, with the tie down connection bolt running down between the two joists.

Bracing walls parallel to joists

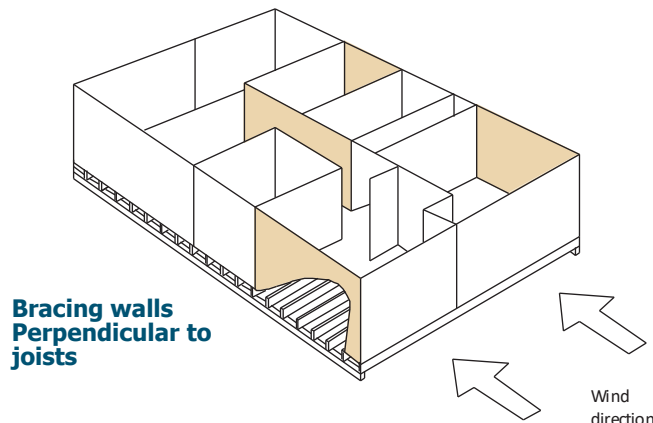
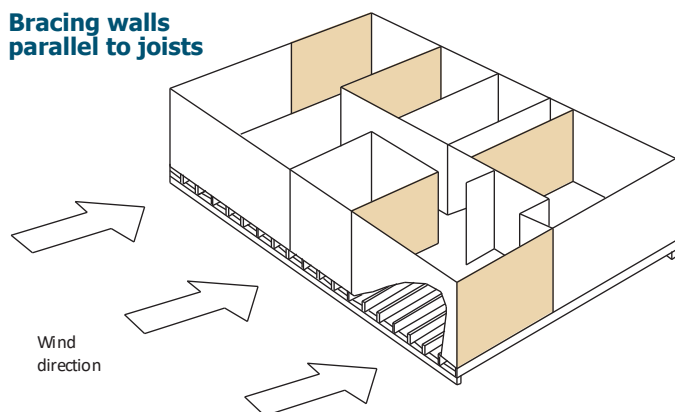

The tie-down and bracing of any structure is of critical importance to its robustness. While some general guidance on this topic is given in AS 1684 sections 8 and 9 including some specific examples, very little information is provided to designers where the bracing or tie down forces act within a floor diaphragm, or how to transfer the design loads specified in table 8.18 to supporting members.

Below are some examples that may be helpful to designers utilis-

ing SmartJoist floor joists but these examples must in no way be a substitute for expert engineering advice from an experienced structural engineer.

Any member, especially tall slender sections typical of floor joists experience significant reduction in strength at the location of a vertical hole. Typically a vertical hole is deemed to have an effect of 1.5 times the diameter of the hole.

Bracing walls between parallel joists

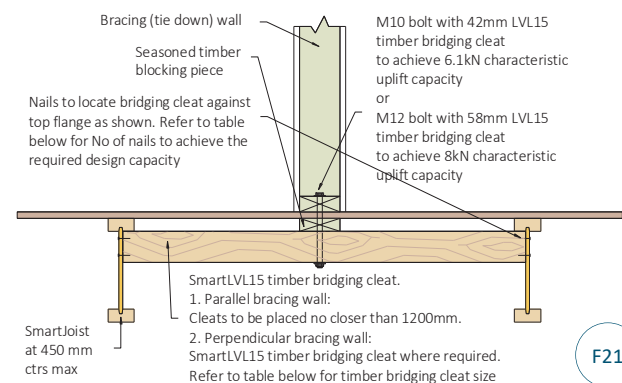

Timber bridging size (DxB mm)	No of nails through SmartJoist web to bridging	Design wind downward capacity (kN) $1.2G + W_{dn}$
90x42/58 SmartLVL 15	2/3.15 \emptyset x 75	4.0
130x42/58 SmartLVL 15	3/3.15 \emptyset x 75	4.9
170x42/58 SmartLVL 15	4/3.15 \emptyset x 75	5.8

Bolt or screw into timber bridging	Design wind uplift capacity (kN)
1/M10 bolt with 42 mm LVL 15 bridging	6.1
1/M12 bolt with 58 mm LVL bridging	8.0
1/14 g Type 17 screw penetrating a MIN. 40 mm into timber bridging	2.0

Tie down and bracing wall support details (cont'd)

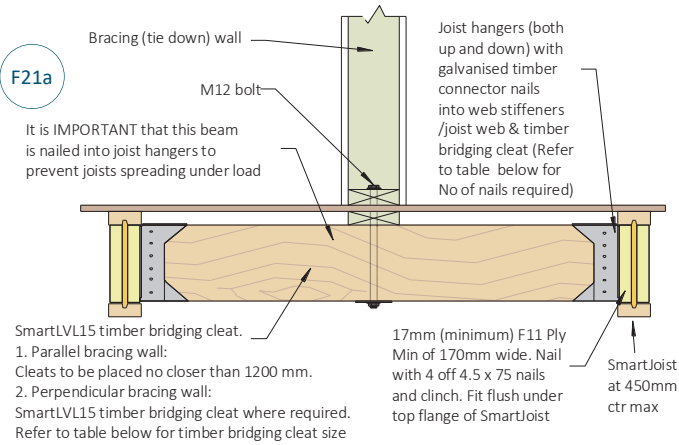

Nails or screws (detail f21g)	Design wind uplift capacity (kN)
2/3.05 ϕ screws, min 40 mm penetration into joist	0.15
1/12g Type 17 screw, min 40 mm penetration into joist	1.5
1/14g Type 17 screw, min 40 mm penetration into joist	1.7

Timber bridging size (DxB mm)	Hanger code	No of hanger nails into joist	No of hanger nails into bridging	Design uplift and downward capacity (kN)
90 x 58 LVL 15	FB5890	8/3.15 ϕ x 35	4/3.15 ϕ x 35	9.6
130 x 58 LVL 15	FB58120	12/3.15 ϕ x 35	6/3.15 ϕ x 35	13.6
170 x 58 LVL15	FB58170	20/3.15 ϕ x 35	10/3.15 ϕ x 35	20.0

Bracing walls vertically above parallel joists

(a) Low capacity

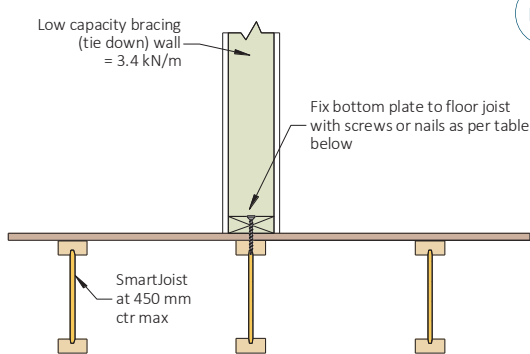

(b) High capacity

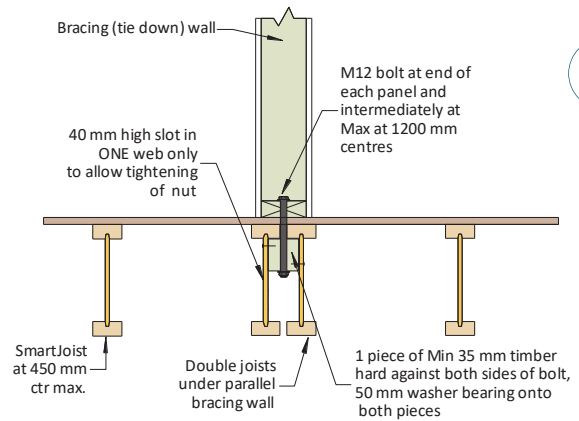

(a) Low capacity

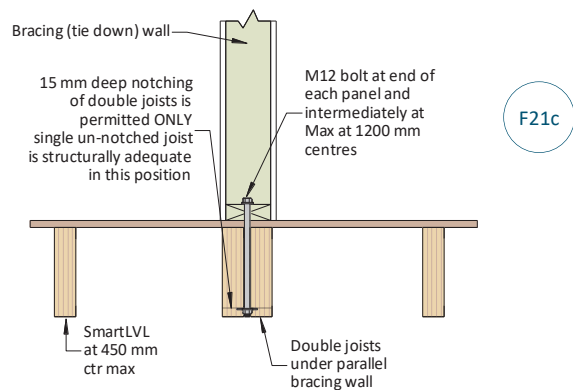

Nails or screws	Design wind uplift capacity (kN)
2/3.05 ϕ screws, min 35 mm penetration into joist	0.5
1/12g Type 17 screw, min 35 mm penetration into joist	2.4
1/14g Type 17 screw, min 35 mm penetration into joist	2.7

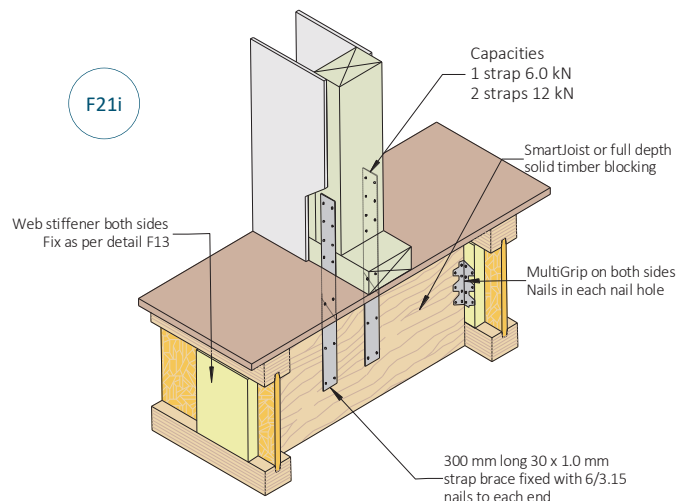
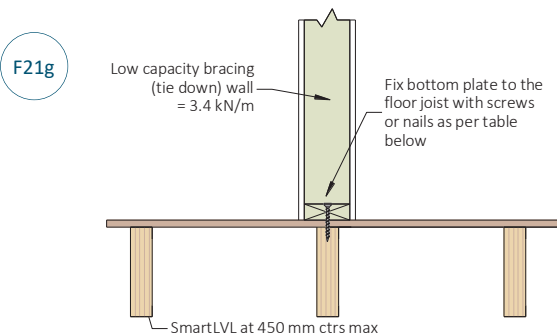

(See capacities next column)

Tie down and bracing wall support details (cont'd)

(a) SmartJoist parallel to upper bracing wall - via web stiffeners

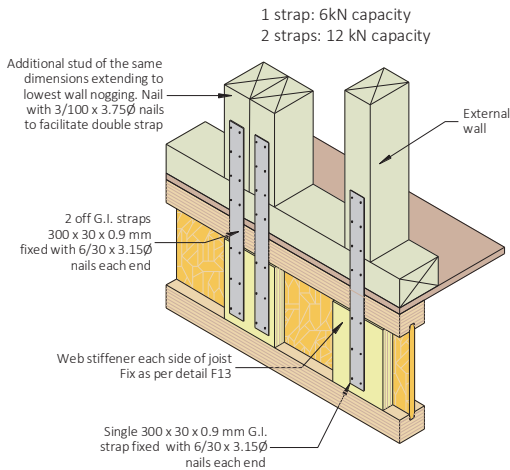

F21j

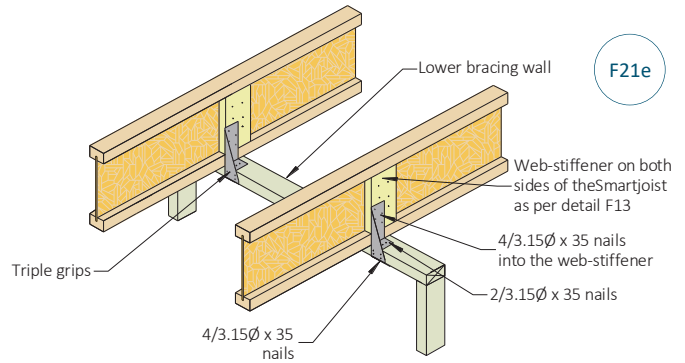

F21e

Limit State design shear capacity per Joist (kN)		
Joint group of joist/top plate	JD4	JD5
2/3.05 Ø skew nails as per AS 1684.2	1.1	0.9
2/3.3 Ø skew nails as per AS 1684.2	1.2	1.0
2/3.05 Ø skew nails + 1 Triple Grip	2.1	1.5
2/3.3 Ø skew nails + 1 Triple Grip	2.2	1.6
2/3.05 Ø skew nails + 2 Triple Grips	4.8	3.7
2/3.3 Ø skew nails + 2 Triple Grips	4.9	3.8

(b) SmartJoist parallel to upper bracing wall - via SmartRim and web stiffeners

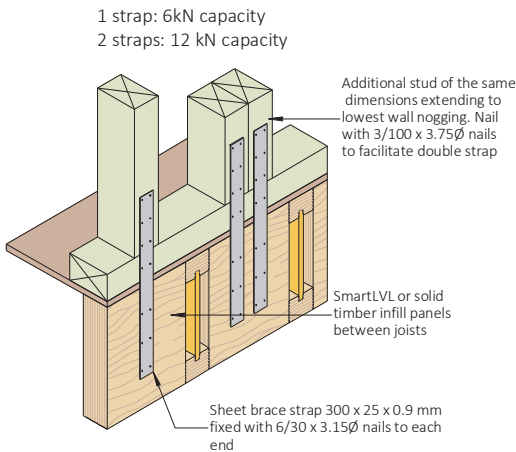

F21k

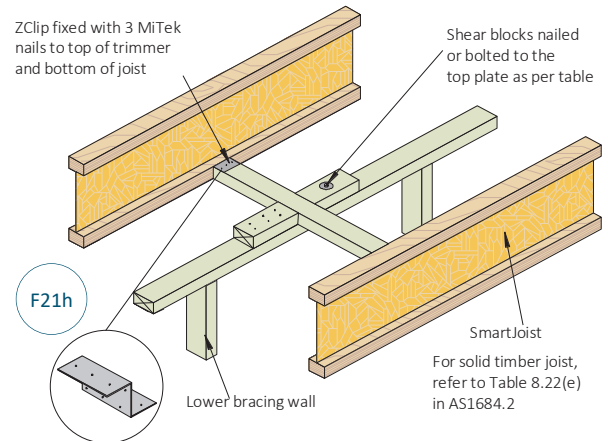

F21h

Fixing to the top of walls

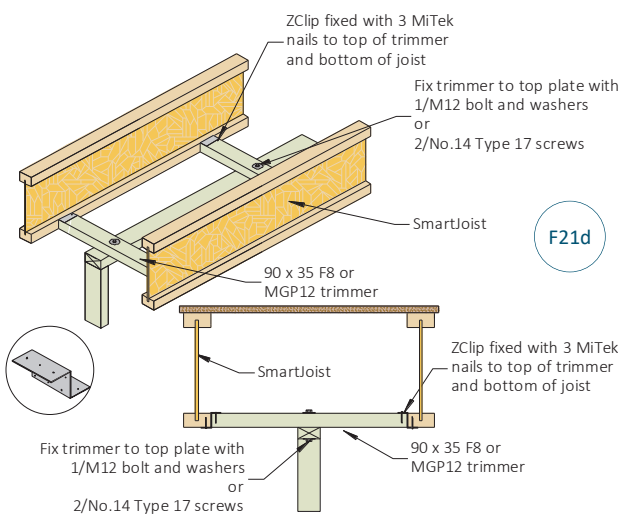

F21d

Limit State design shear capacity (kN)		
Nails/bolts	JD4	JD5
4/3.05 Ø nails	3.6	3.0
4/3.3 Ø nails	4.0	3.3
1 M10 bolt	4.3	3.0
1/M12 bolt	4.6	3.6

Limit State design shear capacity per pair of Zclips		
Joint group of joist/top plate	JD4	JD5
Bracing shear (kN)	4.6	3.6

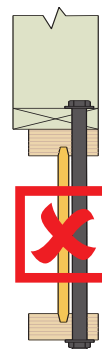

Do not drill through either flange of SmartJoists unless they are fully supported on wall plate or similar

Cyclone rod tie down for cantilevered SmartJoist floors

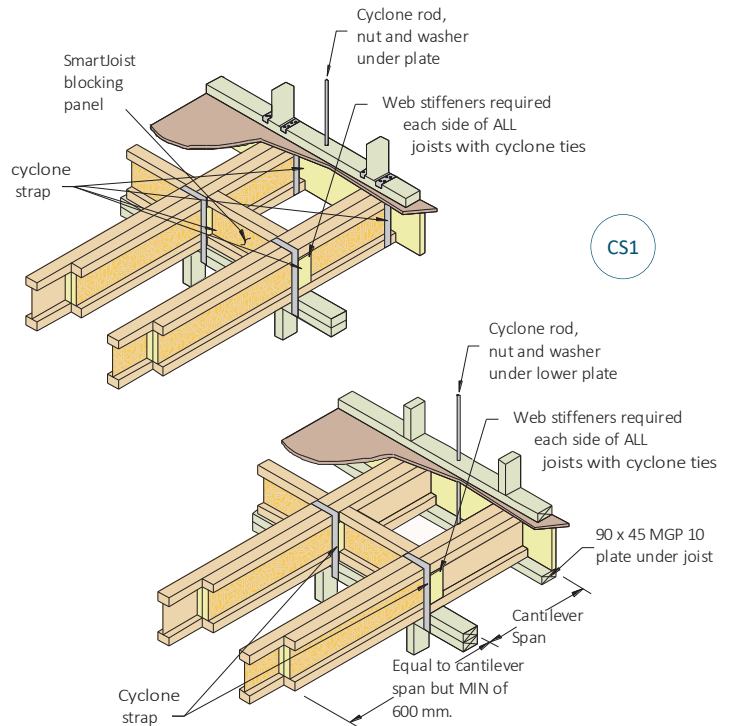
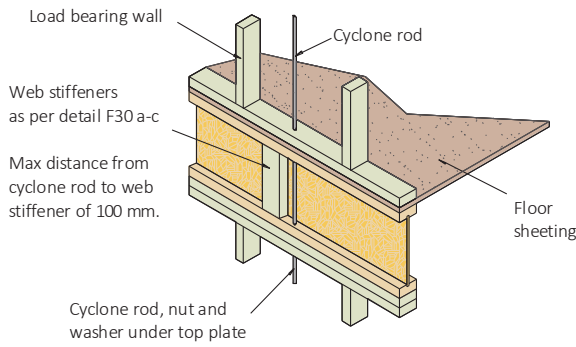

CS1

Cyclone strap capacities

Where the strap ends of the cyclone strap are wrapped around the wall plate or other timber member and are fixed with 4 of 3.15 Ø x 35 nails, the design capacity ϕN_j of 15.3 kN is applicable, regardless of the timber joint group. Tests have proven that bending the legs of cyclone straps around the timber increases the ultimate load capacity.

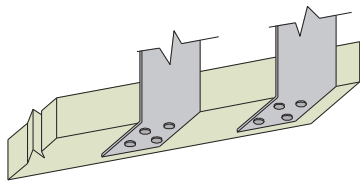

While double joists shown in the above diagram, it is only necessary when loads exceed the capacities of single joist cantilevers.

SmartJoist rafter tie-down

SmartJoist rafters need to be tied down in wind uplift situations in a similar manner to solid timber as shown in section 9 of AS 1684. It is beyond the scope of this document to show tie down requirements for every case.

The examples shown in this section are equally applicable to SmartJoists except that web stiffeners as per detail F12a and R1 must be installed to the SmartJoists where either skewed nails or framing anchors are chosen as the tie down method before the uplift capacities in the tables in section 9 of AS 1684 can be adopted.

All tie down types that involve a strap over the top of the SmartJoist rafters, or involving the bolting down of a member above the rafter running in the perpendicular direction, require no modification to the SmartJoist and therefore uplift capacities in the tables in section 9 of AS 1684 may be used.

The SmartFrame software has a tie-down module in which the development of tie down systems complying with section 9 of AS 1684 can be easily designed.

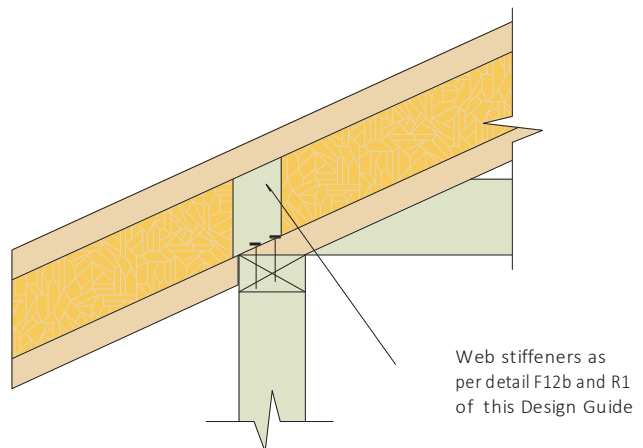
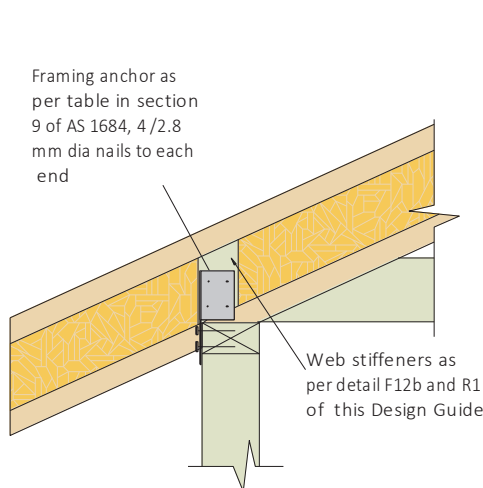

SmartJoist as rafters

About roofs

Roof members are subject to dead and live loads as well as wind loads. These wind loads can act either down onto the roof, or can create an uplift effect. For roofs of light construction, the uplift loads generally control the maximum span, whereas it is usual for dead and live loads to be the controlling factors for heavier roofs (e.g. tiles).

SmartJoists, by their large depth to width ratio, perform well in roof situations providing that their upper and lower flanges have adequate lateral support provided by battens and/or ceiling materials. Due to this fact, the spans in the table below only apply for roofs which meet the following criteria:

1. Enclosed building

2. Ceiling fastened to the underside of bottom flange or adequate lateral supports to bottom flange at a minimum of 600 mm centres
3. Roofs are constructed as per details R1 to R9 of this manual
4. Batten spacing at a maximum of 1200 centres

Tie downs

Wind loadings on light roofs can produce net uplift pressures. The same requirements and methods of tie down apply to SmartJoists as for solid timber roof members except that any tie down system must extend over the top flange. Guidance for tie down requirements are provided in AS 1684 series but with specific adaptations for SmartJoists as shown in detail xxx and xxx on page yyy

Wind Classification N1 - N3

Max Deflections DL: Min span/300 or 20 mm LL: Span/250 WL: Span/150 Max Slope = 25°.

Joist Code	Roof mass (kg/m ²)	Single span @ 25° pitch				Continuous 2 span @ 25° pitch			
		Rafter/roof beam spacing (mm)							
		450	600	900	1200	450	600	900	1200
Recommended maximum rafter span - Plan dimension (mm)									
SJ20044	40	5400	5000	4400	4100	N/A ⁽¹⁾	N/A ⁽¹⁾	N/A ⁽¹⁾	4550
	90	3850	3500	3050	2750	N/A ⁽¹⁾	4900	4250	3800
SJ24040	40	5600	5150	4500	4100	N/A ⁽¹⁾	N/A ⁽¹⁾	4850	4300
	90	4350	3950	3450	3100	N/A ⁽¹⁾	4750	4050	3550
SJ24051	40	6000	5550	4850	4450	N/A ⁽¹⁾	N/A ⁽¹⁾	N/A ⁽¹⁾	5200
	90	4700	4250	3700	3350	N/A ⁽¹⁾	N/A ⁽¹⁾	4950	4350
SJ24070	40	6600	6050	5350	4850	N/A ⁽¹⁾	N/A ⁽¹⁾	N/A ⁽¹⁾	N/A ⁽¹⁾
	90	5100	4650	4050	3650	N/A ⁽¹⁾	N/A ⁽¹⁾	N/A ⁽¹⁾	N/A ⁽¹⁾
SJ24090	40	7000	6500	5750	5250	N/A ⁽¹⁾	N/A ⁽¹⁾	N/A ⁽¹⁾	N/A ⁽¹⁾
	90	5500	5050	4400	3950	N/A ⁽¹⁾	N/A ⁽¹⁾	N/A ⁽¹⁾	N/A ⁽¹⁾
SJ25570	40	6800	6400	5800	5400	N/A ⁽¹⁾	N/A ⁽¹⁾	N/A ⁽¹⁾	N/A ⁽¹⁾
	90	5700	5300	4600	4100	N/A ⁽¹⁾	N/A ⁽¹⁾	6000	N/A ⁽¹⁾
SJ30040	40	6600	6100	5400	4850	N/A ⁽¹⁾	N/A ⁽¹⁾	N/A ⁽¹⁾	N/A ⁽¹⁾
	90	5200	4700	4100	3700	N/A ⁽¹⁾	N/A ⁽¹⁾	N/A ⁽¹⁾	N/A ⁽¹⁾
SJ30051	40	7100	6550	5800	5300	N/A ⁽¹⁾	N/A ⁽¹⁾	N/A ⁽¹⁾	N/A ⁽¹⁾
	90	5600	5050	4450	4000	N/A ⁽¹⁾	N/A ⁽¹⁾	N/A ⁽¹⁾	N/A ⁽¹⁾
SJ30070	40	7800	7200	6350	5800	N/A ⁽¹⁾	N/A ⁽¹⁾	N/A ⁽¹⁾	N/A ⁽¹⁾
	90	6100	5550	4850	4400	N/A ⁽¹⁾	N/A ⁽¹⁾	N/A ⁽¹⁾	N/A ⁽¹⁾
SJ30090	40	8250	7700	6800	6250	N/A ⁽¹⁾	N/A ⁽¹⁾	N/A ⁽¹⁾	N/A ⁽¹⁾
	90	6550	6000	5200	4700	N/A ⁽¹⁾	N/A ⁽¹⁾	N/A ⁽¹⁾	N/A ⁽¹⁾
SJ36058	40	8450	7950	7000	6400	N/A ⁽¹⁾	N/A ⁽¹⁾	N/A ⁽¹⁾	N/A ⁽¹⁾
	90	6750	6150	5400	4850	N/A ⁽¹⁾	N/A ⁽¹⁾	N/A ⁽¹⁾	N/A ⁽¹⁾
SJ36090	40	9150	8650	7800	7150	N/A ⁽¹⁾	N/A ⁽¹⁾	N/A ⁽¹⁾	N/A ⁽¹⁾
	90	7550	6900	6000	5450	N/A ⁽¹⁾	N/A ⁽¹⁾	N/A ⁽¹⁾	N/A ⁽¹⁾
SJ40058	40	8450	7950	7250	6750	N/A ⁽¹⁾	N/A ⁽¹⁾	N/A ⁽¹⁾	N/A ⁽¹⁾
	90	7050	6600	5900	5550	N/A ⁽¹⁾	N/A ⁽¹⁾	N/A ⁽¹⁾	N/A ⁽¹⁾
SJ40090	40	9650	9150	8350	7750	N/A ⁽¹⁾	N/A ⁽¹⁾	N/A ⁽¹⁾	N/A ⁽¹⁾
	90	8150	7450	6500	5900	N/A ⁽¹⁾	N/A ⁽¹⁾	N/A ⁽¹⁾	N/A ⁽¹⁾

NOTE: ⁽¹⁾ Maximum Continuous spans exceed the maximum available length of the SmartJoist

SmartJoist as rafters (Cont'd)

Sloped roof span and cut lengths

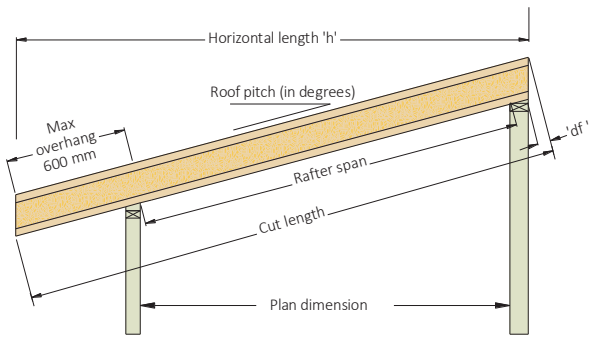

Roof slope degrees	Slope factor 's _f '	Depth factor 'd _f '				
		Joist depth (mm)				
		200	240	300	360	400
15.0	1.04	54	64	80	96	107
17.5	1.05	63	76	95	113	126
20.0	1.06	73	88	109	131	146
22.5	1.08	83	99	124	149	166
25.0	1.10	93	112	140	168	187
27.5	1.13	104	125	156	187	208
30.0	1.15	115	139	173	208	231
35.0	1.22	140	168	210	252	280

span (mm) = plan dimension x slope factor (s_f)

Cut length (mm) = horizontal length (h) x slope factor (s_f) + depth factor (d_f) = h x s_f + d_f

SmartJoist box gutter details

1. Roof - Rebates for box gutters are permissible within a roof constructed with SmartJoist rafters to the MAXIMUM rebate limits as shown below.

- Fig BG1 with 2 pieces of 90 x 45 nailed to the web reduces shear capacity by 40%
- Fig BG2 with 2 pieces of 17 mm F14 ply nailed to the web maintains full shear capacity

Given that the design shear values at the end of rafters with light weight roofs are usually very low compared to the allowable shear, in most instances figure BG1 is satisfactory to provide a box gutter rebate within the SmartJoist rafters, however the remaining shear capacity MUST be checked.

2. Tanked balconies - Fig BG2 may on occasions, be used for balcony/deck joists that require a drain at one end.

The extra loads associated with FC sheets for tiling/watertightness means that these joists should be designed carefully for each individual application.

It is recommended that designers wishing to cut box gutter rebates in SmartJoist rafters or deck joists contact the tech support helpline on 1300 668 690 or at techsupport@tilling.com.au for further advice on this issue.

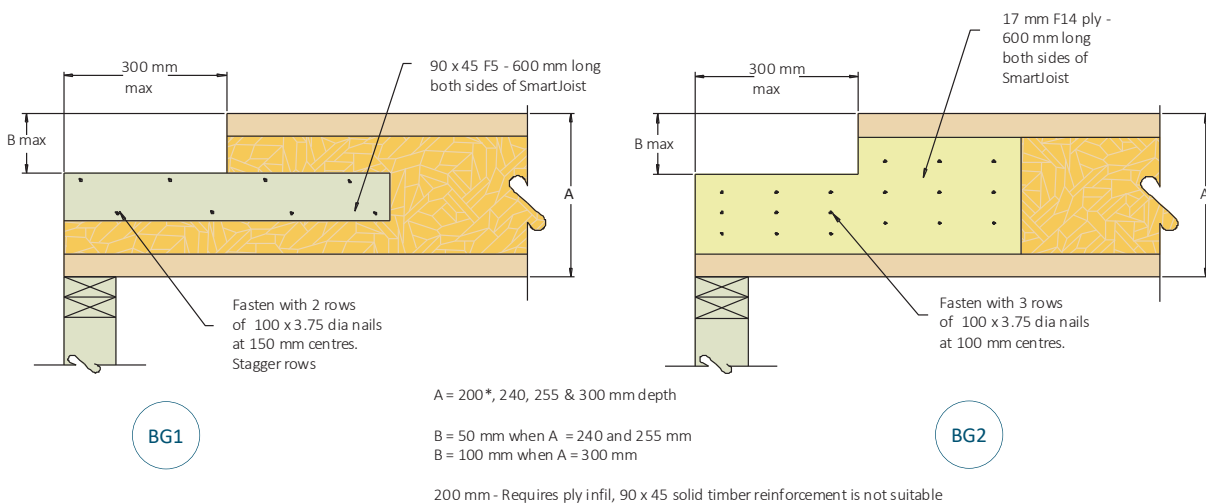

SmartFrame bevelled bearing plates

The use of bevelled bearing plates makes the use of lightweight SmartJoists as rafters even more attractive, removing the need for most, if not all joist hangers. From its sophisticated wood working equipment such as CNC cutting and machining tools, Tilling Timber can supply ancillary components to further revolutionise the rapid and cost effective installation of SmartJoist roof systems

- Single and double bevel plates for rafter angles from 6° to 24° slope from 90 mm wide seasoned softwood can be supplied as an integral part of a long span lightweight SmartJoist roof layout
- SmartJoist rafters can on request, be supplied plumb cut on either one or both ends
- Waler bevel plate for rafter angles 6° to 45° slope from either SmartLVL or seasoned softwood can be supplied as an integral part of a SmartJoist roof layout.

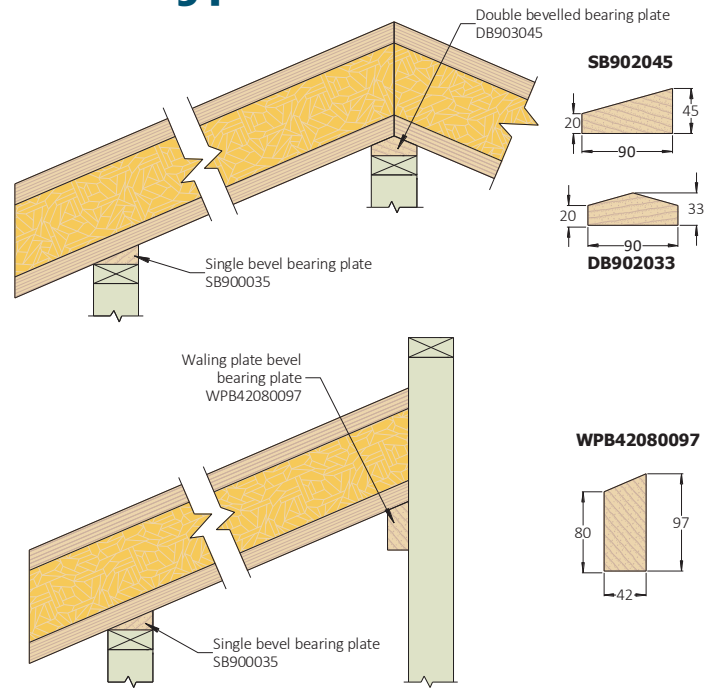

Example single bevel bearing plate

Example SmartFrame bevel plate sizes for 90 mm wide plate, nil front upstand			
Roof slope°	Height (mm)	Roof slope°	Height (mm)
6	9	16	26
8	13	18	29
10	16	20	33
12	19	22	36
14	22	24	40

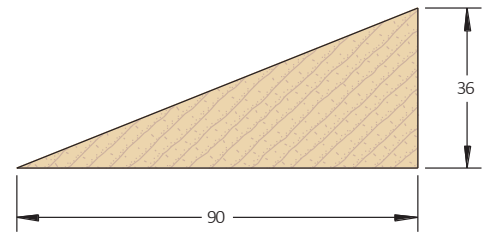

Notes:

- SmartFrame bevelled bearing plates, where requested, are designed by the Design Centre into a SmartJoist roof system layout. They are not sold individually as they are custom made only for the associated SmartFrame roof system and are not a stocked item
- SmartFrame bevelled bearing plates can be supplied in seasoned softwood or Smart LVL, depending upon the application
- Allow five (5) working days from placement of order for non-retreated members, allow 10 working days for bevelled bearing plates requiring H2f treatment of cut face
- Bevelled bearing plates with a nil front upstand (triangular shape) for roof slopes less than 6° are not available because of the difficulty of cutting and small wood volume likely to split when nailed. It is recommended for low slope rafters that a 20 mm front upstand be used.

Strong-Drive® SDWC Truss screw

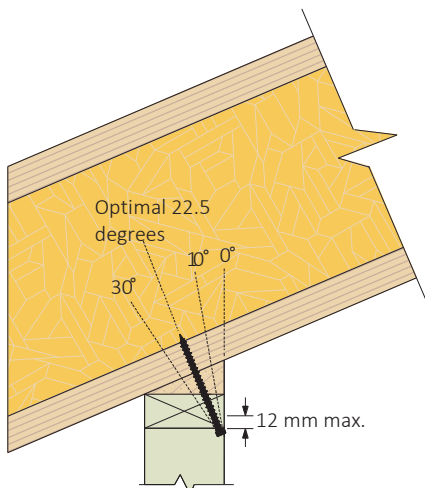

A clean, neat screw system that connects both the SmartJoist rafter and Smart-Frame bevelled bearing plate to the wall top plate.

The SDWC Truss screw is tested for uplift and lateral loads between wall plates and vertical wall framing and between the top plate and the roof rafters or trusses. The SDWC screw is recognised for use in chemically treated timber.

Installation Guides and Capacity tables for the SDWC system are available from www.strongtie.com.au.



Typical SmartJoist Roof details

Warning:
Do not allow workers or loads on roof until ALL blocking, hanger, bracing and fastening is completed.
See Safety warning

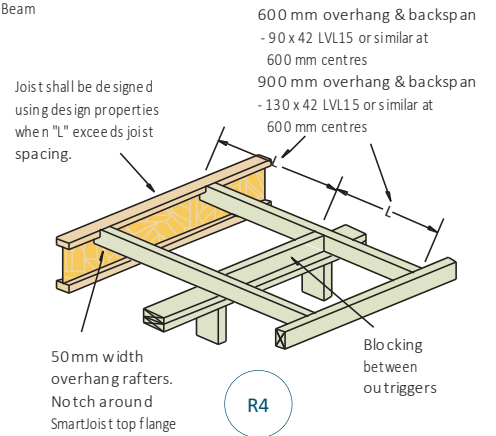
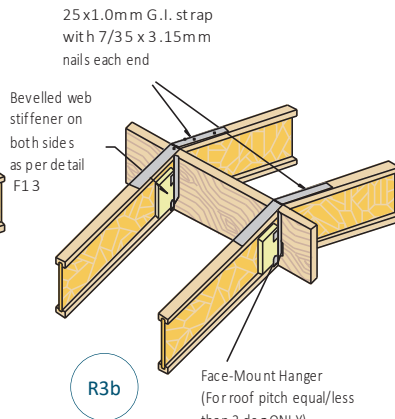
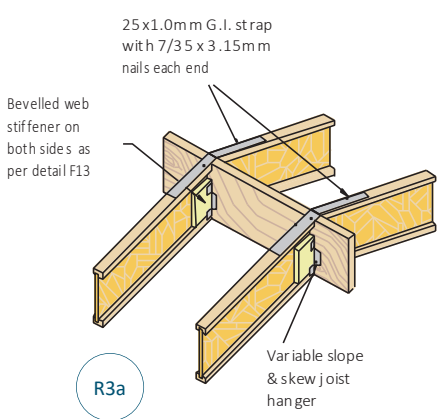
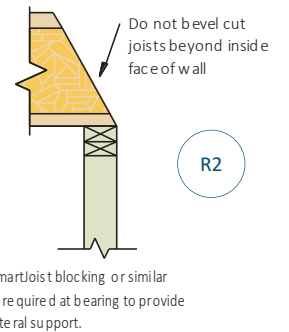
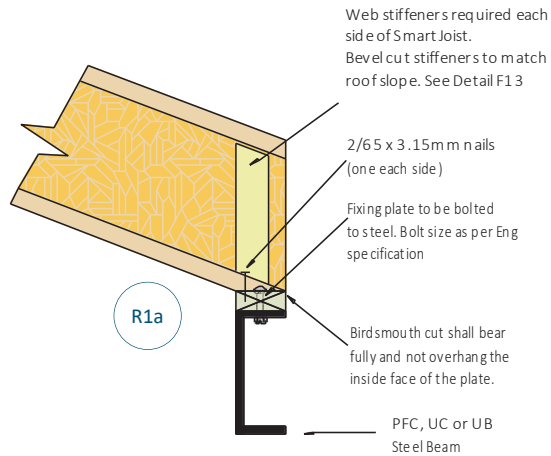
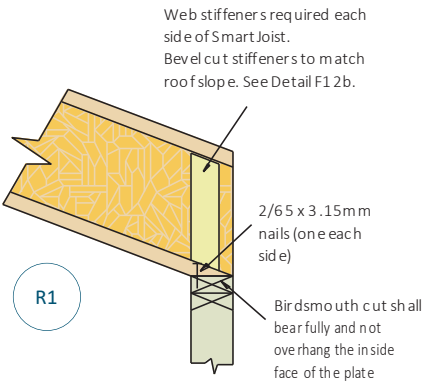
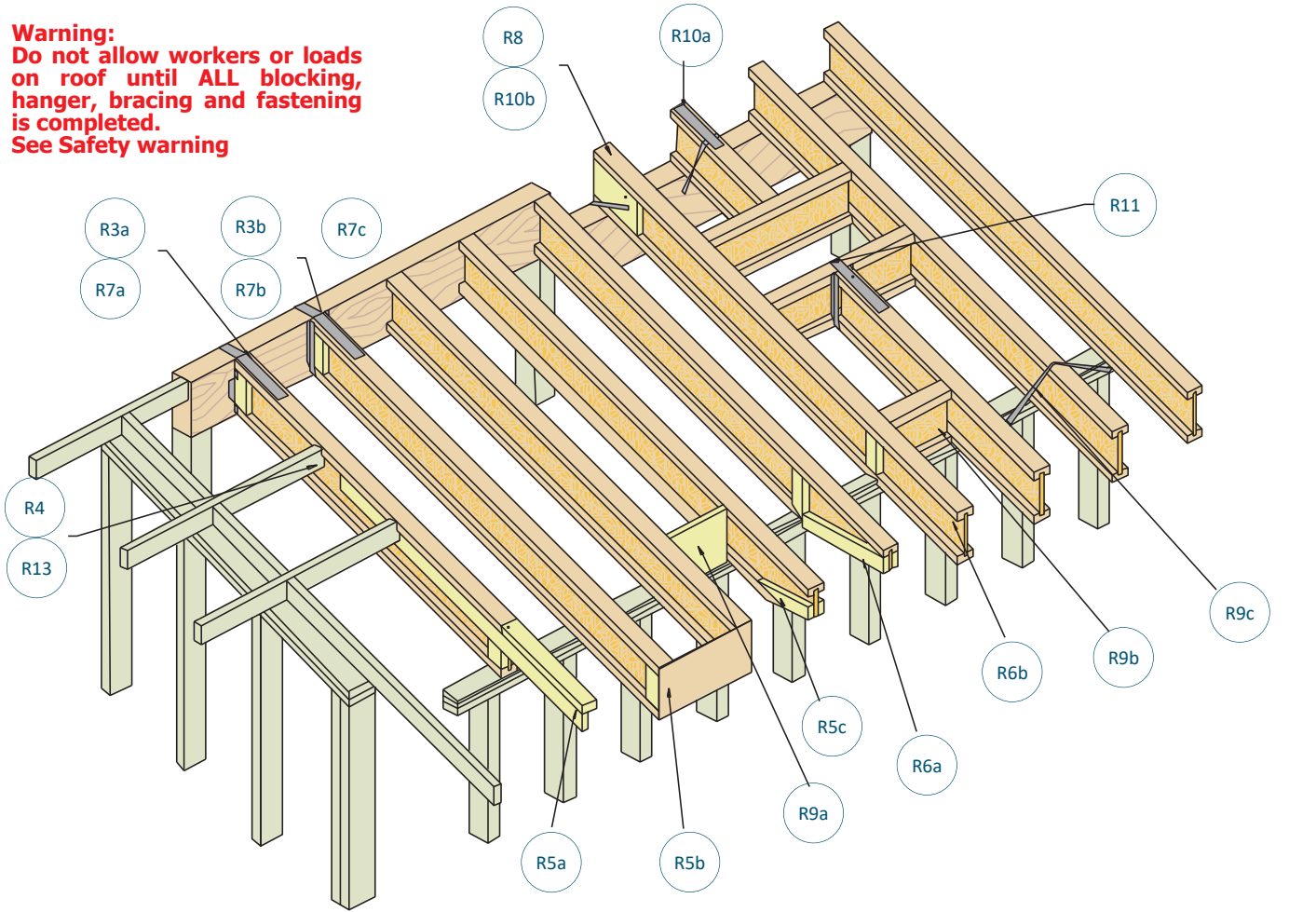

Note: Tie-down details to be designed to AS 1684.2 for the respective wind loads with the SmartFrame software

Typical SmartJoist Roof details (cont'd)

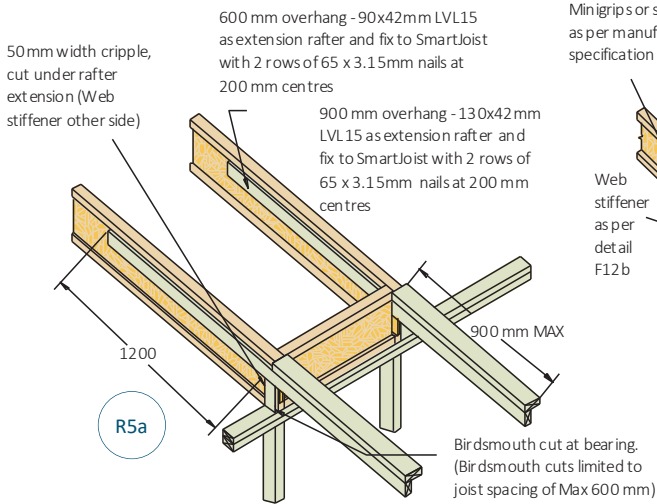

R5a

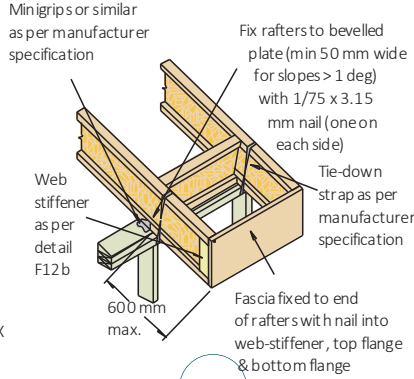

R5b

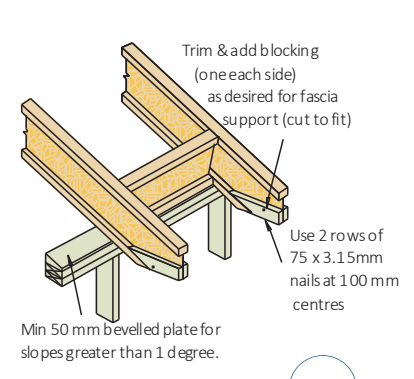

R5c

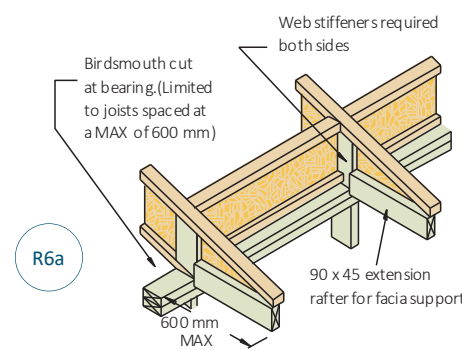

R6a

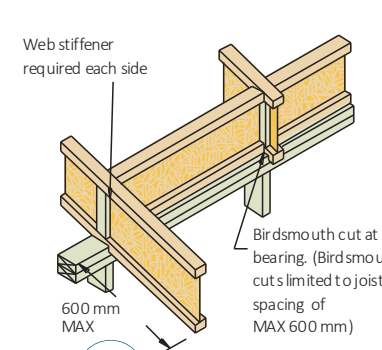

R6b

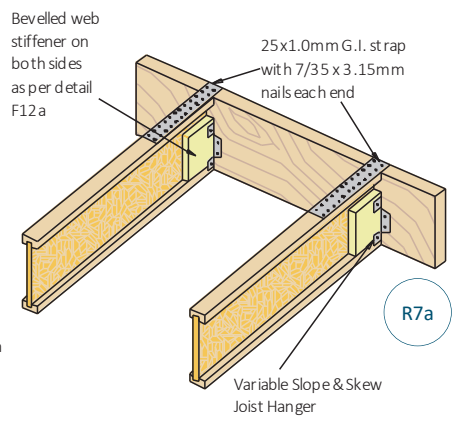

R7a

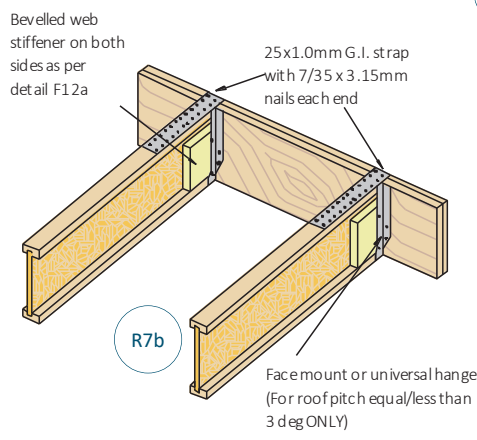

R7b

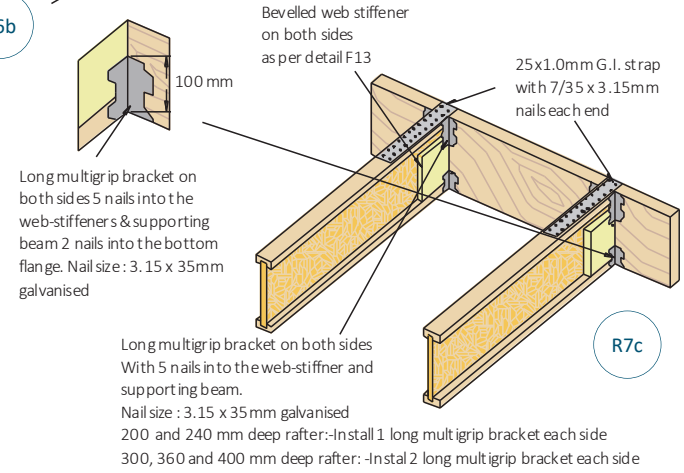

R7c

Rafter tie-down and blocking

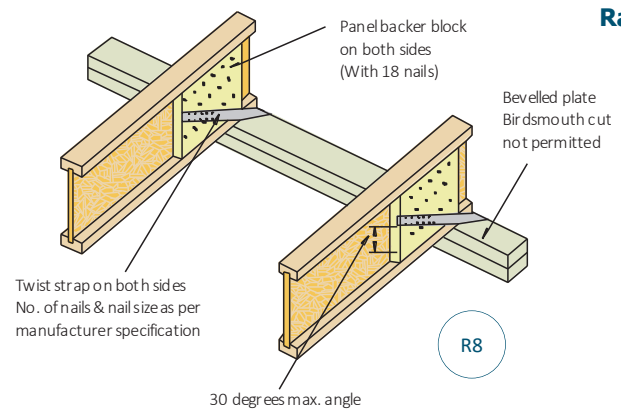

R8

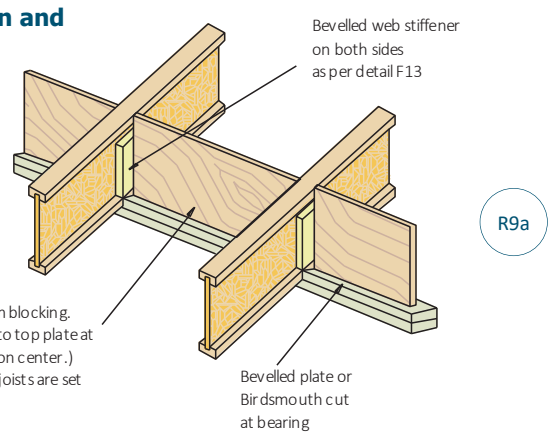

R9a

Typical SmartJoist Roof details (cont'd)

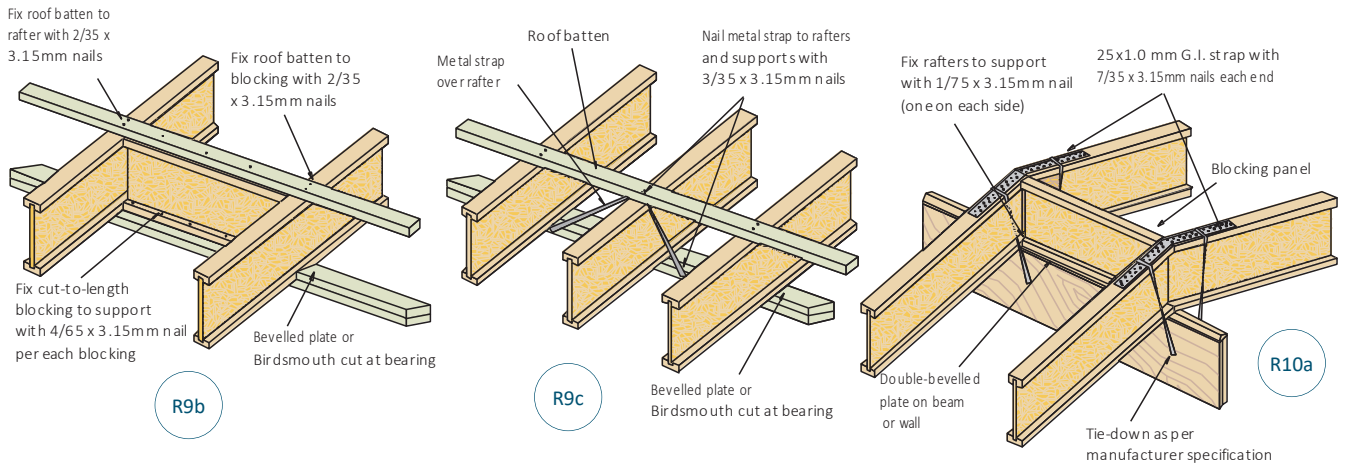

Lateral restraint at supports

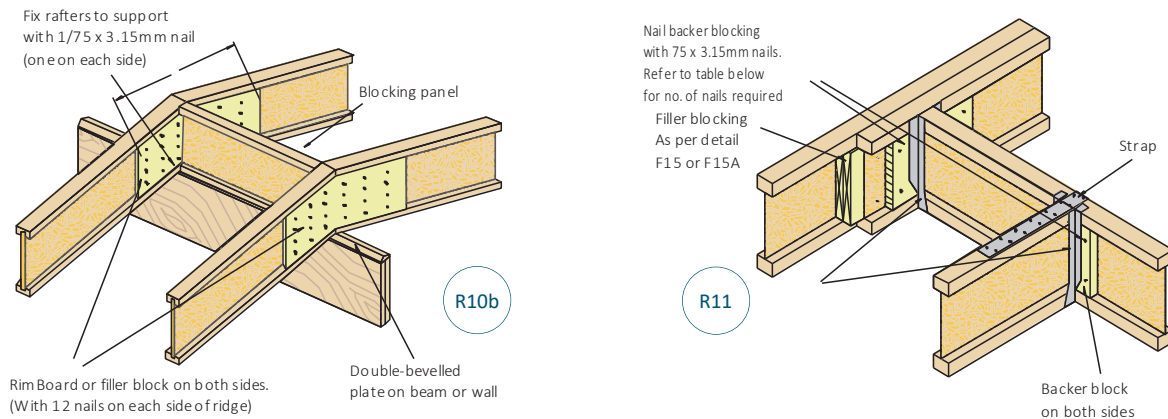

Trimming of roof openings

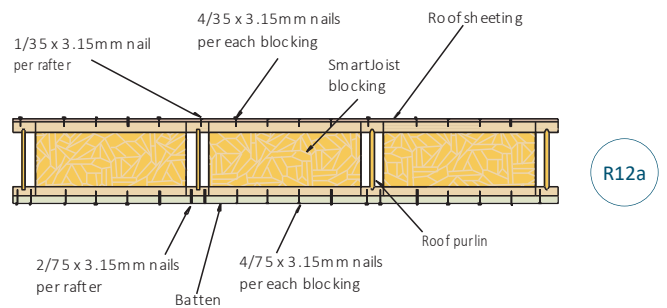

Lateral restraint - SmartJoist blocking fixing

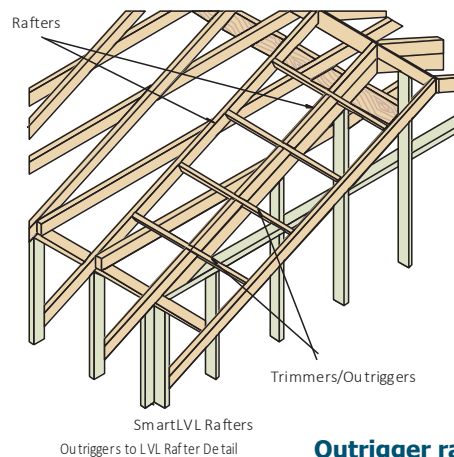

Outrigger rafters - LVL

Lateral restraint for rafters - Use of ceiling options to provide lateral support

R12

SmartJoist roof cassettes

The lightweight long spanning SmartJoists are ideal roof components for mono-slope and pitched roof applications, both parallel and perpendicular to the roof slope.

Sophisticated CAD design systems and CNC manufacturing processes adopted by Tilling Timber nationally has meant that the benefits of offsite manufacture of SmartJoist roof cassettes using SmartJoists and other products from the SmartFrame family of EWP where necessary, had rapidly become mainstream in the Australian market.

Since designing and building the approx. 3600 m² floor cassettes for the inaugural five (5) storey lightweight framed class 2 building in Australia in 2014, the SmartFrame Design Centre has continued to expand a well experienced dedicated cassette team that specialises in the design and production of shop drawing for sophisticated cassettes.

For further information about the application of offsite manufactured SmartFrame cassettes in your project please contact tech support helpline on 1300 668 690 or at techsupport@tilling.com.au.

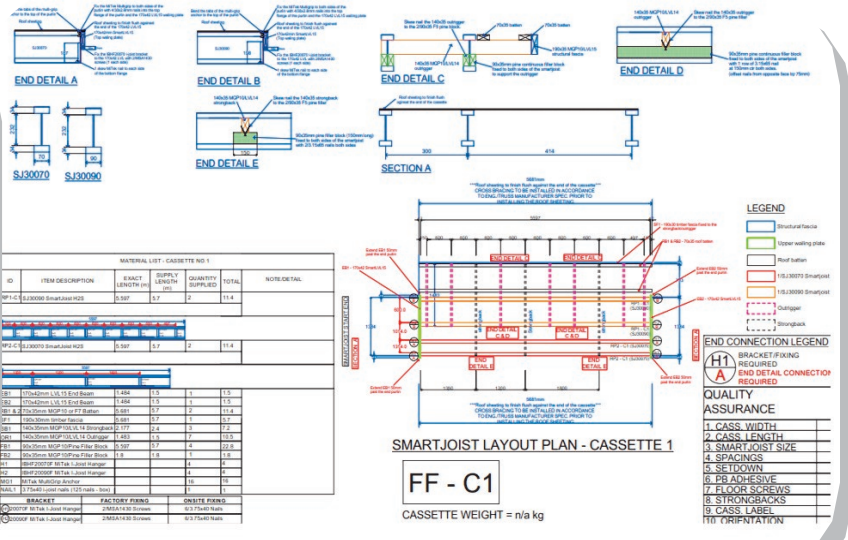

SMART FRAME[®]
POWERED BY INNOVATION

Safe loading of materials on a SmartJoist working platform

IMPORTANT!! Joists must be fully braced or have floor sheeting installed before applying any of the following loads.

SmartJoist Code	Joist Spacing up to 600 mm Max weight (kg) per joist	SmartJoist Code	Joist Spacing up to 600 mm Max weight (kg) per joist
SJ20044	180	SJ30051	295
SJ24040	210	SJ30070	345
SJ24051	235	SJ30090	390
SJ24070	270	SJ36058	395
SJ24090	300	SJ36090	475
SJ25570	290	SJ40058	450
SJ30040	265	SJ40090	535

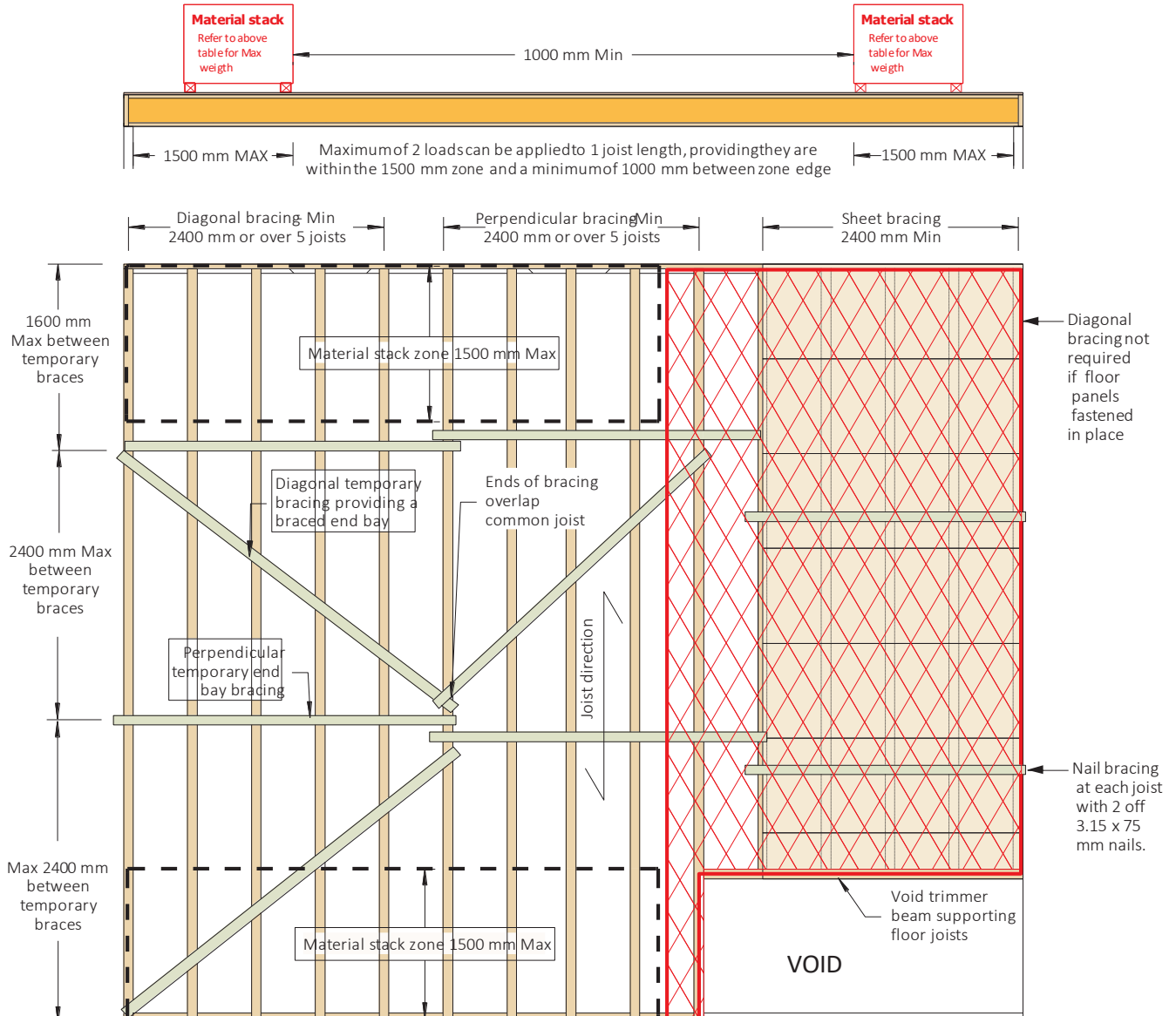

Notes:

- All end blocking or Rim Boards must be in place, and fastened as per fixing instructions on page 8 of this document
- NO loads are to be stacked over any part of the lengths of the joists fixed to an opening header or trimmer joist such as a stair trimmer
- Loads are to be spread equally over a minimum of 2 joists, using timber bearers at a minimum of 1200 mm in length or a standard 1200 x 1200 pallet.
- The long dimension of temporary loads shall be placed perpendicular to the framing and only located within the material stack zone shown above.
- Joists on hangers may require propping
- Bracing lines to be 90 x 35 F5 or similar
- Perpendicular bracing to run full width of floor. Long lengths (2400 mm min.) are recommended with the ends overlapped at a common joist
- Remove temporary bracing carefully. Starting with diagonal bracing at one end, only remove enough bracing to attaching flooring panels one at a time. Once diagonal bracing is replaced by the permanently installed flooring, the work can progress across the floor, again only removing the perpendicular bracing as necessary before attaching floor sheeting panels
- If unsure about stacking concentrated loads on SmartJoist working platforms, please contact the tech support helpline on 1300 668 690.

Fire safety and acoustics - Class 2 and 3 buildings (Multi-residential)

Introduction

The National Construction Code (NCC) sets out the minimum requirements for design and construction of new building work (including in existing buildings), plumbing and drainage across all Australian States and Territories.

It provides uniform technical standards for the design, construction and performance of all buildings and structures, including these key priorities:

- safety (structural safety and fire safety)
- health
- amenity
- accessibility
- sustainability.

The NCC applies to any design and new building work (including in existing buildings), plumbing and drainage work, anywhere in Australia. All work of this type is legally required to meet the minimum regulations described in the code.

1. Fire

Section C in the BCA Volume 1 outlines the performance requirements for fire resistance, and Specifications C1.1 outlines the Deemed-to-Satisfy (DTS) Fire-Resisting construction requirements of building elements, including floors.

The Fire Resistance Level (FRL) is expressed as the number of minutes for which the specimen fulfils the requirements of each of the three criteria, being:

- i. Structural adequacy
- ii. Integrity; and
- iii. Insulation, and expressed in that order

The performance of a specimen is then given as the actual time for which the specimen satisfied these criteria, but rounded down to the nearest regulatory requirements. E.g. 60/60/60.

A SmartJoist floor system may be utilised in class 2 and 3 floor applications, defined as **Lightweight Construction** in Schedule 3 of the NCC.

Specification C1.13a contains requirements for **fire-protected timber**, thus a SmartJoist floor system complying with the provisions of this specification may be used.

The use of SmartJoists as **fire-protected timber** in a floor application is supported by two(2) expert assessment documents:

FRL 90/90/90: Warringtonfire Assessment Report No 37600400 - Timber-framed floor/ceiling system incorporating various timber and metal web floor trusses or engineered joists achieving an FRL of 90/90/90.

FRL 120/120/120: Warringtonfire Assessment Report No FAS190034 - Timber-framed floor/ceiling system incorporating various timber and metal web floor trusses or engineered joists achieving an FRL of 120/120/120.

Note: The design and detailing of lightweight construction with fire-protected timber requires expert knowledge in this field, and the information contained within this Design Guide is included to provide **Evidence of Suitability** for the SmartJoist as a fire-protected timber in floor applications only.

Further information about designing for fire is available for all building classes in the Wood Solutions Design available at www.woodsolutions.com.au.

Sound transmission

The ability of walls and floors to reduce noise is measured over the most important part of the hearing range (from 125 to 4000 cycles per second), and the results reduced to a “weighted sound reduction index” or R_w value. In 2004, the NCC introduced the addition of a Spectrum Adaption factor. This C_{tr} factor takes into account lower frequency level sounds, and has been chosen in large part, in recognition of the problem of the high bass frequency outputs of modern home theatre systems and amplified music systems. Therefore, both the C_{tr} and the R_w of the building element will now need to be considered.

In addition to being rated for airborne sound transmission, floors are also rated by “Impact sound pressure level” or $L'_{n,w}$ plus the spectrum adaption factor C_i values that rate the capacity of floor assemblies to control impact noise such as footfalls. The lower the $L'_{n,w} + C_i$ of the floor, the better the performance of the floor in terms of impact sound insulation

Part F5.4(a) The NCC requires a $R_w + C_{tr}$ (airborne) of 50 and $L'_{n,w}$ not more than 62 in floors between sole occupancy units and between dwellings and a plant room, lift shaft, stairway, public corridor, public lobby or similar.

The use of light-frame construction systems challenges designers to insulate against noise rather than simply relying on the massiveness of heavy walls and floors. Excellent levels of noise control can be achieved with good acoustics in wood framed structures surfaced with wood structural panels. Sound control can be achieved by applying floor and wall materials over isolated air spaces that absorb sound. The addition of resilient channels to support the ceiling system independently increases the $R_w + C_{tr}$ and $L'_{n,w} + C_i$ ratings.

The best current understanding indicates that the systems – walls, floors and ceiling” as detailed in the Wood Solutions manuals “*Design and construction guide for NCC compliant fire-rated construction* can be used to closely approximate the $R_w + C_{tr}$ and $L'_{n,w} + C_i$ rating of floor/ceiling systems with SmartJoist floor joists. Work is under way to further investigate the link between joist types and impact sound insulation.

For further details on the various certified systems see www.woodsolutions.com.au or contact the engineers on the tech support helpline on 1300 668 690 or at techsupport@tilling.com.au.

Note: The design and detailing of lightweight construction for acceptable acoustic performance requires expert knowledge in this field, and the information contained within this Design Guide is included to provide Evidence of Suitability for the SmartJoist in acoustic rated floor applications only.

A typical SmartJoist floor system for a Class 2 or 3 building is shown on the next page, with it associated Fire and Acoustic values.

Extra information about the use of SmartFrame product in class 2-9 structures, contact the SmartFrame engineers on the tech support helpline on 1300 668 690.

Fire safety and acoustics - Class 2 and 3 buildings (Multi-residential)

Example SmartJoist floor/ceiling system in conformance with NCC Deemed-to-Satisfy provisions

Typical system Acoustic value			NCC Compliant values	
Airborne	Impact		Airborne	Impact
R_w/R_w+C_{tr}	Bare floor $L_{n,w}$	Carpet + Underlay $L_{n,w}$	R_w+C_{tr}	$L_{n,w}$
59/51	60-62	45-50	>50	<62

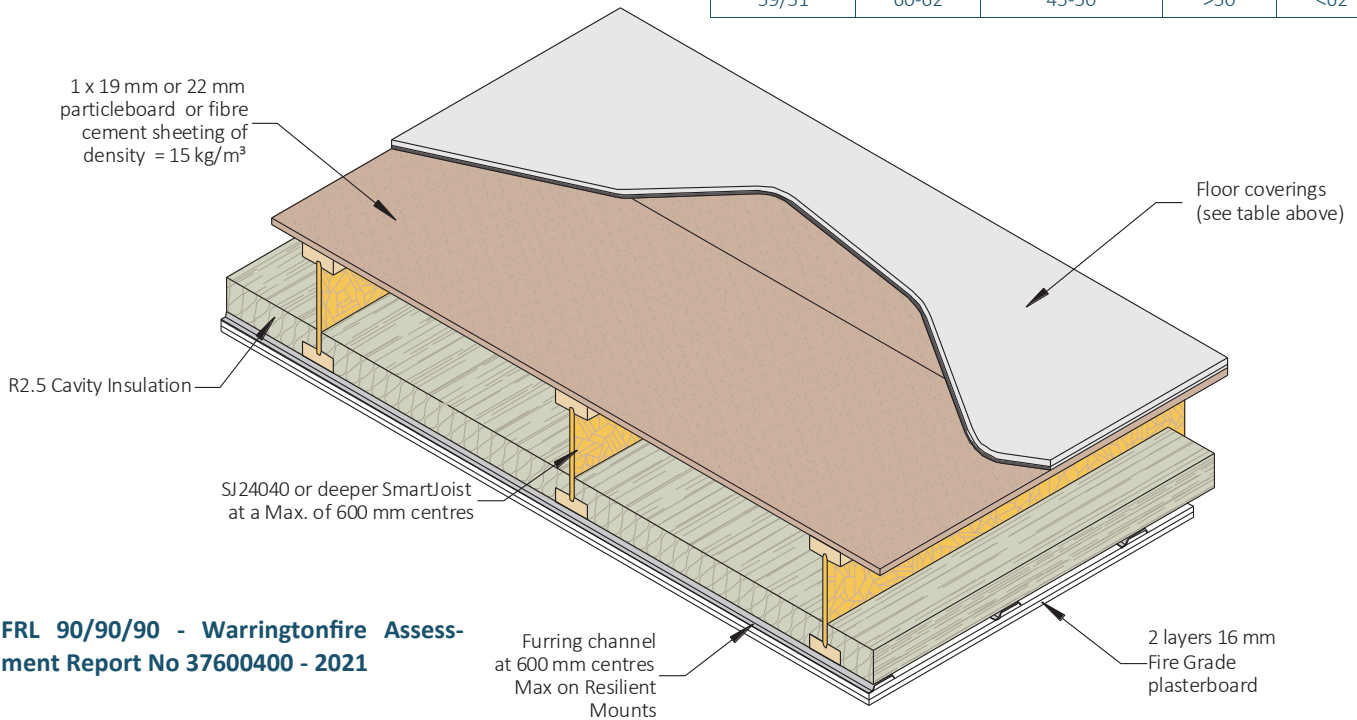

FRL 90/90/90 - Warringtonfire Assessment Report No 37600400 - 2021

Preservative treatment

The treatment of timber to extend its service life is covered by AS/NZS 1604. This code identifies the various biological hazards by a hazard class number, with hazard class numbers from H1 - H6. The higher the hazard class number, the greater the severity of the biological hazard. A complete table listing the 6 hazard classes is contained within AS/NZS 1604.1.

All SmartJoists are supplied H2s treated per the table below, or alternatively may be after-market H2 treated by an experienced and approved timber preserver. Water borne treatments are NOT suitable for SmartJoists.

It is also NOT recommended that SmartJoists be specified for use outside above ground, even if H3 treated. This is predominately due to the geometric shape of the I-Joist which will not shed water effectively.

Further information on treated I-Joists can be obtained on 1300 668 690 or at techsupport@tilling.com.au

Hazard Class	Exposure	Specific service conditions	Biological hazard	Typical uses
H1*	inside, above ground	Completely protected from the weather and well ventilated, and protected from termites	Lyctid borers	Interior beams, stair cases, stringers
H2s	inside, above ground	South of the Tropic of Capricorn ONLY Protected from weather, Nil leaching	Borers and termites	Interior joists, rafters and roof beams
H2	inside, above ground	Protected from weather, Nil leaching	Borers and termites	Interior joists, rafters and roof beams

* All SmartJoists are manufactured from materials not susceptible to Lyctid attack

Adhesive and formaldehyde emission facts sheet

Q. Are the glues used in SmartFrame Engineered Wood Products safe?

A. Yes, they are safe, Phenolic resins used in our Engineered Wood Products are stable, polymerised materials. The polymerisation reaction is non-reversible (i.e. once the polymer is formed, it doesn't break down). A wood dust warning label is provided for all SmartFrame wood products to alert our customers that wood dust can be generated by sawing, sanding, or machining wood and wood products.

Q. What is the level of formaldehyde emission from our phenolic-bonded Engineered Wood Products?

A. Independent third party testing has confirmed that formaldehyde emissions from our phenolic-bonded products (i.e. OSB, LVL, and I-Joists) are below 0.5 mg/L under reasonably foreseeable conditions of use, which meets or exceeds the E₀ Formaldehyde Emission Class

In short, all available information indicates that formaldehyde levels associated with phenolic resin-bonded wood products are similar to those of the dimension lumber veneer or other forms of wood used to make the products.

Q. How much formaldehyde is in our phenolic-bonded, Engineered Wood Products?

A. The amount of formaldehyde in our Engineered Wood Products is less than 0.1 percent of the dry weight.

Q. What is being done to reduce the exposure to formaldehyde?

A. Formaldehyde is normally present at low levels, usually lower than 0.03 ppm, in both outdoor and indoor air. Efforts have been made by both government and industry to reduce exposure to formaldehyde. A 1985 regulation by the US Department of Housing and Urban Development (HUD), covering the use of manufactured pressed wood products in housing was designed to ensure that indoor levels were below 0.4 ppm. Product standards established for plywood and particleboard led to significant reductions in formaldehyde emissions from those products. Furthermore, HUD acknowledged that phenolic resin bonded wood products emitted such small quantities of formaldehyde that these products were exempted from all the testing and certification requirements of the standards. In Germany, the German Hazardous Materials regulation, better known as the "E1" Standard, sets a limit of 1.0 mg/L for formaldehyde emissions from some wood-based composite products. All available data indicates that our phenolic bonded Engineered Wood Products meet the more stringent E₀ level.

Q. What affects formaldehyde levels in a home?

A. Formaldehyde levels in the indoor air depend mainly on what is releasing the formaldehyde, the temperature, the humidity, and the air exchange rate (i.e. the amount of outdoor air entering or leaving the indoor area) Levels of formaldehyde decrease with increasing air exchange rate, decreasing temperature, and decreasing humidity.

SMARTFRAME[®]

POWERED BY INNOVATION



SmartJoist Design Guide



Tilling website



SmartJoist Installation Guide

Head Office

Victoria

31-45 Orchard Street,
Kilsyth Vic 3137

email: sales@tilling.com.au

Phone +61 3 9725 0222

Fax +61 3 9725 3045

New South Wales

109 Kurrajong Avenue,
Mt Druitt, NSW 2770

email: nswsales@tilling.com.au

Phone +61 2 9677 2600

Fax +61 2 9677 2500

Queensland

84 Magnesium Drive,
Crestmead QLD 4132

email: qldsales@tilling.com.au

Phone +61 7 3440 5400

Fax +61 7 3440 5444

Western Australia

10 Cartwright Drive
Forrestdale WA 6112

email: wasales@tilling.com.au

Phone +61 8 9399 1609

Fax +61 8 9399 1065

South Australia

5-9 Woomera Ave
Edinburgh SA 5111

email: sasales@tilling.com.au

Phone +61 8 8345 1966

Fax +61 8 8345 1977

Sales 1800 33 77 03 Technical support 1300 66 86 90

© 2021 Tilling Timber Pty Ltd ABN 92 004 621 121 Date of publication Aug 2021 SmartFrame is a Registered Trademark of Tilling Timber

